

DRAWING NO.

10051634

BURNDY MOLD CAT. NO.	BURNDY ITEM NUMBER	CABLE SIZE	WELD METAL	HANDLE CLAMPS
B-1626	10048899	#6	65	B-106
B-1627	10048900	#4	65	B-106
B-1628	10048901	#2	65	B-106
B-1629	10048902	#1	90	B-106
B-1630	10048903	1/0	115	B-106
B-1631	10048904	2/0	115	B-106
B-1632	10048905	3/0	150	B-106
B-1633	10048906	4/0	150	B-106
B-1634	10048907	250 kcmil	150	B-106

REV.	DATE	DESCRIPTION	ECO	BY	C'K'D.
A	12/8/04	DRAWING RELEASED	10262	PL	DS

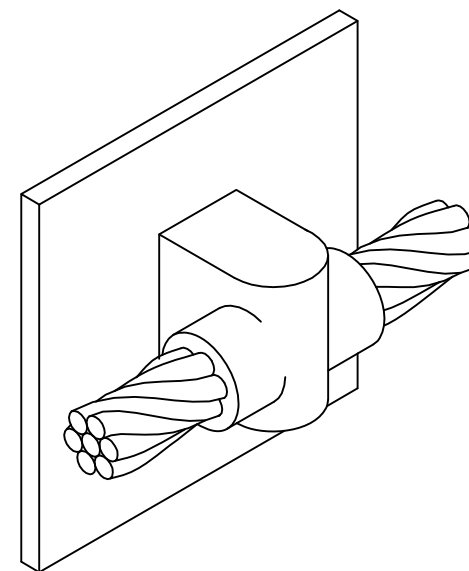

(CABLE IS OFF THE SURFACE)

**NOTES:**

- BCS-6 TYPE MOLDS ARE USED TO JOIN HORIZONTAL THROUGH COPPER CABLE TO A VERTICAL STEEL SURFACE. NOTE THAT THE CABLE IS OFF 'OFF' THE SURFACE.
- SIZE RANGE IS #6 THROUGH 250 kcmil SOLID OR CONCENTRIC STRANDED COPPER CONDUCTORS.
- MOLDS LISTED ARE FOR CONCENTRIC STRANDED CABLE. ADD SUFFIX '-S' TO MOLD NUMBER FOR SOLID CONDUCTORS. FOR HEAVY DUTY MOLDS, ADD SUFFIX 'H' TO MOLD NUMBER.
- REQUIRED TOOLS:  
HANDLE CLAMPS (SEE CHART FOR CORRECT HANDLES). FOR HANDLES SEE DRAWING 10051615.  
B38-0309-00: FLINT IGNITOR (DRAWING 10051616).
- OTHER RECOMMENDED ACCESSORIES: DRAWING 10051616  
B40-0319-01: MOLD CLEANER FOR CARTRIDGE SIZES #15 - #65  
B40-0319-03: MOLD CLEANER FOR CARTRIDGE SIZES #90 - #500  
B38-3922-00: MOLD CLEANING BRUSH  
B38-0135-00: CABLE CLEANING BRUSH  
B38-0101-00: RASP

TO ORDER BURNDY® PRODUCTS CALL  
UNITED STATES:  
1-800-346-4175 (LONDONDERRY, NH)  
CANADA:  
1-800-361-6975 (QUEBEC)  
1-800-387-6487 (ALL OTHER PROVINCES)  
FOR PRODUCT INFO: <http://www.burndy.com>

BURNDYweld™ HORIZONTAL THRU CABLE TO VERTICAL STEEL SURFACE	
ITEM NO: N/A	
CAT NO: BCS-6 SERIES	
SCALE: N/A	<b>BURNDY</b>
DRAWN BY: P LAPINIUS 12/8/04	
CHECKER: D SHIBILIA 1/3/05	
DSN APPVL: D SHIBILIA 1/13/05	
MFG APPVL: -- --	
QC APPVL: J BRODEUR 1/14/05	
MKT APPVL: R ROBICHEAU 1/18/05	
PROD FAM: --	DRAWING NO
PROJECT #: --	10051634
DOCUMENT TYPE: Sales	SIZE
REL LEVEL: AutoCAD	D
	SHEET 1 OF 1
	REV
	A