

DRAWING NO.
10051636

BURNDY MOLD CAT. NO.	BURNDY ITEM NUMBER	CABLE SIZE	WELD METAL	HANDLE CLAMPS
B-5910	10048940	#6	45	B-106
B-2761	10048941	#4	45	B-106
B-2569	10048942	#2	45	B-106
B-6060	10048943	#1	65	B-106
B-5419	10048944	1/0	90	B-106
B-2567	10048945	2/0	90	B-106
B-6072	10048946	3/0	115	B-106
B-9253	10048947	4/0	115	B-106
B-2568	10048948	250 kcmil	115	B-106
B-6061	10048949	300 kcmil	150	B-106
B-6067	10048950	350 kcmil	200	B-106
B-8359	10048951	500 kcmil	200	B-106

REV.	DATE	DESCRIPTION	ECO	BY	C*K'D.
B	12/03/12	DRAWING LOGO CHANGED.	29615	YM	MB

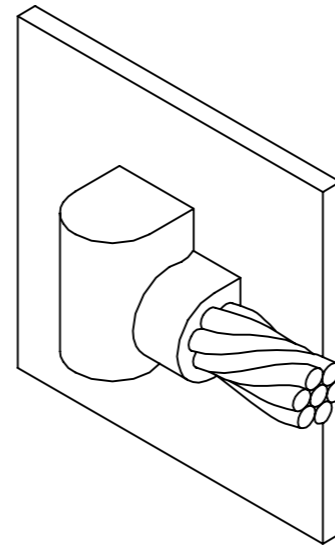

(CABLE IS ON THE SURFACE)

NOTES:

- BCS-18 TYPE MOLDS ARE USED TO CONNECT A HORIZONTAL CONDUCTOR TO A VERTICAL STEEL SURFACE. NOTE THAT THE CABLE IS 'ON' THE SURFACE.
- SIZE RANGE IS #6 THROUGH 500 kcmil SOLID OR CONCENTRIC STRANDED COPPER CONDUCTORS.
- ADD "-R" TO THE MOLD NUMBER FOR RIGHT HAND MOLD OR "-L" FOR LEFT HAND MOLD. RIGHT HAND "-R" MOLD WILL BE FURNISHED IF NOT SPECIFIED.
- MOLDS LISTED ARE FOR CONCENTRIC STRANDED CABLE. ADD SUFFIX "-S" TO MOLD NUMBER FOR SOLID CONDUCTORS. FOR HEAVY DUTY MOLDS, ADD SUFFIX "H" TO THE MOLD NUMBER.
- REQUIRED TOOLS:
HANDLE CLAMPS (SEE CHART FOR CORRECT HANDLES). FOR HANDLES SEE DWG. 10051615.
B38-0309-00: FLINT IGNITOR (DRAWING 10051616).
- OTHER RECOMMENDED ACCESSORIES: DRAWING 10051616.
B38-3922-00: MOLD CLEANING BRUSH
B38-0135-00: CABLE CLEANING BRUSH
B38-0101-00: RASP

<p>TO ORDER BURNDY® PRODUCTS CALL</p> <p>UNITED STATES: 1-800-346-4175 (LONDONDERRY, NH)</p> <p>CANADA: 1-800-361-6975 (QUEBEC) 1-800-387-6487 (ALL OTHER PROVINCES)</p> <p>FOR PRODUCT INFO: http://www.burndy.com</p>	BURNDYWeld™ HORIZONTAL TAP CABLE TO VERTICAL STEEL SURFACE	
	ITEM NO: N/A	
	CAT NO: BCS-18 SERIES	
	SCALE: N/A	
	DRAWN BY: P LAPONIUS	12/8/04
	CHECKER: D SHIBILIA	1/3/05
	DSN APPVL: D SHIBILIA	1/13/05
	MFG APPVL: ---	---
	QC APPVL: J BRODEUR	1/14/05
	MKT APPVL: R ROBICHEAU	1/18/05
PROJ FAM: ---		DRAWING NO
PROJECT #: ---	SIZE	10051636
DOCUMENT TYPE: Sales	D	SHEET 1 OF 1
REL LEVEL: AutoCAD		B

