

BURNDY MOLD CAT. NO.	BURNDY ITEM NUMBER	BUS BAR SIZE	CABLE SIZE	WELD METAL	HANDLE CLAMPS
B-1651	10049578	1/4" X 1-12" & WIDER	1/0	90	B-106
B-1652	10049579	1/4" X 1-12" & WIDER	2/0	90	B-106
B-1653	10049580	1/4" X 1-12" & WIDER	3/0	90	B-106
B-1654	10049581	1/4" X 1-12" & WIDER	4/0	90	B-106
B-1655	10049582	1/4" X 1-12" & WIDER	250 kcmil	115	B-106
B-1656	10049583	1/4" X 1-12" & WIDER	300 kcmil	115	B-106
B-1657	10049584	1/4" X 1-12" & WIDER	350 kcmil	150	B-106
B-1659	10049585	1/4" X 1-12" & WIDER	500 kcmil	200	B-106
B-1660	10049586	3/8" X 1-12" & WIDER	1/0	90	B-106
B-1661	10049587	3/8" X 1-12" & WIDER	2/0	90	B-106
B-1662	10049588	3/8" X 1-12" & WIDER	3/0	115	B-106
B-1663	10049589	3/8" X 1-12" & WIDER	4/0	115	B-106
B-1664	10049590	3/8" X 1-12" & WIDER	250 kcmil	150	B-106
B-1665	10049591	3/8" X 1-12" & WIDER	300 kcmil	150	B-106
B-1666	10049592	3/8" X 1-12" & WIDER	350 kcmil	200	B-106
B-1668	10049593	3/8" X 1-12" & WIDER	500 kcmil	250	B-106
B-1669	10049594	3/8" X 1-12" & WIDER	750 kcmil	2-150	B-107
B-1670	10049595	3/8" X 1-12" & WIDER	1000 kcmil	2-200	B-107
B-1671	10049596	1/2" X 1-1/2" & WIDER	1/0	115	B-106
B-1672	10049597	1/2" X 1-1/2" & WIDER	2/0	115	B-106
B-1673	10049598	1/2" X 1-1/2" & WIDER	3/0	150	B-106
B-1674	10049599	1/2" X 1-1/2" & WIDER	4/0	150	B-106
B-1675	10049600	1/2" X 1-1/2" & WIDER	250 kcmil	200	B-106
B-1676	10049601	1/2" X 1-1/2" & WIDER	300 kcmil	200	B-106
B-1677	10049602	1/2" X 1-1/2" & WIDER	350 kcmil	250	B-106
B-1679	10049603	1/2" X 1-1/2" & WIDER	500 kcmil	2-150	B-107
B-1680	10049604	1/2" X 1-1/2" & WIDER	750 kcmil	2-200	B-107
B-1681	10049605	1/2" X 1-1/2" & WIDER	1000 kcmil	500	B-107

REV.	DATE	DESCRIPTION	ECO	BY	C'K'D.
A	12/8/04	DRAWING RELEASED	10262	PL	DS

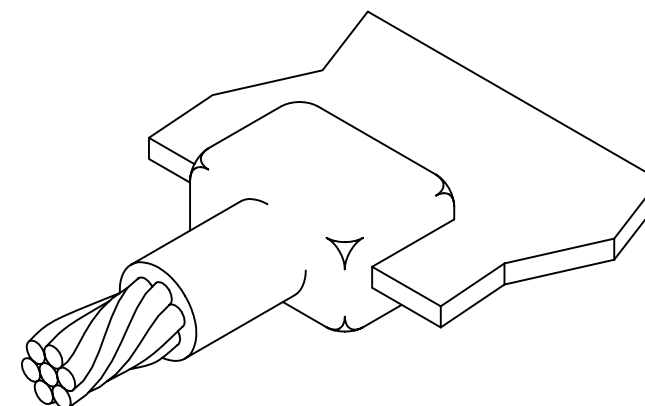

NOTES:

- BCB-4 TYPE MOLDS ARE USED TO CONNECT HORIZONTAL COPPER CABLE TAP TO A HORIZONTAL COPPER BUS BAR WITH THE FLAT SIDE HORIZONTAL.
- SIZE RANGE IS 1/0 THROUGH 1000 kcmil SOLID OR CONCENTRIC STRANDED COPPER CONDUCTORS. BUS SIZE RANGE IS FROM 1/4" X 1" THROUGH 1/2" X 1-1/2" AND WIDER.
- MOLDS LISTED ARE FOR CONCENTRIC CABLE. ADD SUFFIX "-S" TO MOLD NUMBER FOR SOLID CONDUCTORS.
- FOR HEAVY DUTY MOLDS, ADD SUFFIX "H" TO MOLD NUMBER.
- REQUIRED TOOLS:
HANDLE CLAMPS (SEE CHART FOR CORRECT HANDLES). FOR HANDLES SEE DRAWING 10051615.
B38-0309-00: FLINT IGNITOR (DRAWING 10051616).
- OTHER RECOMMENDED ACCESSORIES: DRAWING 10051616
B40-0319-03: MOLD CLEANER FOR CARTRIDGE SIZES #90 - #500
B38-3922-00: MOLD CLEANING BRUSH
B38-0135-00: CABLE CLEANING BRUSH

TO ORDER BURNDY® PRODUCTS CALL
1-800-346-4175 (LONDONDERRY, NH)
CANADA:
1-800-361-6975 (QUEBEC)
1-800-387-6487 (ALL OTHER PROVINCES)
FOR PRODUCT INFO: <http://www.burndy.com>

BURNDYweld™ HORIZONTAL CABLE TAP TO HORIZONTAL BUS	
ITEM NO:	N/A
CAT NO:	BCB-4 SERIES
SCALE:	N/A
DRAWN BY:	P. LAPONIUS 12/8/04
CHECKER:	D. SHIBILIA 1/3/05
DSN APPVL:	D. SHIBILIA 1/13/05
MFG APPVL:	--
QC APPVL:	J. BRODEUR 1/14/05
MKT APPVL:	R. ROBICHEAU 1/18/05
PROD FAM:	--
PROJECT #:	--
DOCUMENT TYPE:	Sales
REL LEVEL:	AutoCAD
DRAWING NO	10051643
REV	A
SHEET 1 OF 1	