

BURNDY MOLD CAT. NO.	BURNDY ITEM NUMBER	REBAR SIZE	CABLE SIZE	PACKING MAT'L (SEE NOTE)	WELD METAL	HANDLE CLAMPS
B-7708	10050011	#3	#6	B38-4060-00	90	B-106
B-7709	10050012	#3	#4	B38-4060-00	90	B-106
B-7710	10050013	#3	#2	B38-4060-00	90	B-106
B-7711	10050014	#3	#1	B38-4060-00	115	B-106
B-7712	10050015	#3	1/0	B38-4060-00	115	B-106
B-7713	10050016	#3	2/0	B38-4060-00	115	B-106
B-7714	10050017	#3	3/0	B38-4060-00	150	B-106
B-7715	10050018	#3	4/0	B38-4060-00	150	B-106
B-7716	10050019	#4	#6	B38-4060-00	90	B-106
B-7717	10050020	#4	#4	B38-4060-00	90	B-106
B-7718	10050021	#4	#2	B38-4060-00	90	B-106
B-7719	10050022	#4	#1	B38-4060-00	115	B-106
B-7720	10050023	#4	1/0	B38-4060-00	115	B-106
B-7721	10050024	#4	2/0	B38-4060-00	115	B-106
B-7722	10050025	#4	3/0	B38-4060-00	150	B-106
B-7723	10050026	#4	4/0	B38-4060-00	150	B-106
B-7724	10050027	#5	#6	B38-4060-00	90	B-106
B-7725	10050028	#5	#4	B38-4060-00	90	B-106
B-7726	10050029	#5	#2	B38-4060-00	90	B-106
B-7727	10050030	#5	#1	B38-4060-00	115	B-106
B-7728	10050031	#5	1/0	B38-4060-00	115	B-106
B-7729	10050032	#5	2/0	B38-4060-00	115	B-106
B-7730	10050033	#5	3/0	B38-4060-00	150	B-106
B-7731	10050034	#5	4/0	B38-4060-00	150	B-106
B-7732*	10050043	#6 & LARGER	#6	B38-4061	90	N/A
B-7733*	10050044	#6 & LARGER	#4	B38-4061	90	N/A
B-7734*	10050045	#6 & LARGER	#2	B38-4061	90	N/A
B-7735*	10050046	#6 & LARGER	#1	B38-4061	115	N/A
B-7736*	10050047	#6 & LARGER	1/0	B38-4062	115	N/A
B-7737*	10050048	#6 & LARGER	2/0	B38-4062	115	N/A
B-7738*	10050049	#6 & LARGER	3/0	B38-4062	150	N/A
B-7739*	10050050	#6 & LARGER	4/0	B38-4062	150	N/A

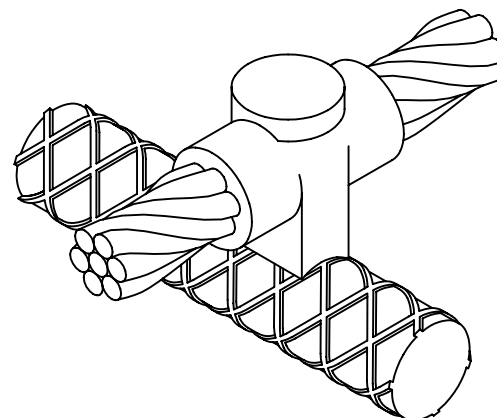

NOTES:

1. BCRC-4 TYPE MOLDS ARE RECOMMENDED FOR HORIZONTAL THROUGH CONDUCTORS TO HORIZONTAL REBAR AT RIGHT ANGLE CONNECTIONS FOR SOLID OR CONCENTRIC STRANDED CONDUCTORS #6 THROUGH 4/0 JOINED TO REINFORCING BARS #3 THROUGH #6 AND LARGER. THE HIGH COPPER CONTENT JOINT HAS A HIGHER CURRENT CARRYING CAPACITY THAN THE CONDUCTORS BEING JOINED AND IS IMPERVIOUS TO VIBRATION AND MOISTURE.

2. A PACKING PAD IS NECESSARY WHEN MAKING BURNDYweld™ CONNECTIONS TO REBAR. PACKING MATERIAL B38-4060-00 IS A SPECIAL, PATENTED COPPER-WOOL PACKING, WITH ENOUGH IN EACH BAG TO DO BETWEEN 40 AND 50 CONNECTIONS. PACKING MATERIAL NO.'S B38-4061-00, B38-4062-00 AND B38-4063-00 ARE A CERAMIC FIBER MATERIAL AND CAN BE USED FOR ONE CONNECTION ONLY. BE SURE TO SPECIFY PACKING MATERIAL NO. WHEN ORDERING MOLD AND WELD MATERIAL.

3. MOLDS LISTED ARE FOR CONCENTRIC STRANDED CABLE. ADD SUFFIX "-S" TO MOLD NUMBER FOR

4. SOLID CONDUCTORS. FOR HEAVY DUTY MOLDS, ADD SUFFIX "H" TO THE MOLD NUMBER.

5. REQUIRED TOOLS: HANDLE CLAMPS (SEE TABLE FOR CORRECT HANDLES). FOR HANDLES SEE DWG. 10051615. B38-0309-00: FLINT IGNITOR (DRAWING 10051616).

6. OTHER RECOMMENDED ACCESSORIES;
 B40-0319-03: MOLD CLEANER FOR CARTRIDGE SIZES #90 - #500
 B38-3922-00: MOLD CLEANING BRUSH
 B38-0135-00: CABLE CLEANING BRUSH
 B38-0304-00: FILE

TO ORDER BURNDY® PRODUCTS CALL
 UNITED STATES:
 1-800-346-4175 (LONDONDERRY, NH)
 CANADA:
 1-800-361-6975 (QUEBEC)
 1-800-387-6487 (ALL OTHER PROVINCES)
 FOR PRODUCT INFO: <http://www.burndy.com>

BURNDYweld™ HORIZONTAL THRU CABLE TO HORIZONTAL REBAR	
ITEM NO:	N/A
CAT NO:	BCRC-4 SERIES
SCALE:	N/A
DRAWN BY:	P LAPONIUS 12/8/04
CHECKER:	D SHIBILIA 1/3/05
DSN APPVL:	D SHIBILIA 1/13/05
MFG APPVL:	J BRODEUR
QC APPVL:	1/14/05 R ROBICHEAU
MKT APPVL:	1/18/05 --
PROJ FAM:	--
PROJECT #:	--
DOCUMENT TYPE:	Sales
REL LEVEL:	AutoCAD
DRAWING NO	10051654
REV	A
SHEET 1 OF 1	