

DRAWING NO. 10066496	CATALOG NO.	ITEM NO.	FIG. NO.	CONDUCTOR		BOLT SIZE	DIMENSIONS										BURNDY® INSTALLATION TOOLING (# CRIMPS)						
				FLEX	CODE (AWG)		B	C	E	H	∅ K	L	N	O.D.	T	Z	DIE INDEX	COLOR CODE	HYDRAULIC			DIELESS (# CRIMPS)	WIRE STRIP LENGTH
							±.09	±.06	±.02	REF.	±.02	±.15	±.06	±.01	REF.	MIN.			Y750 Y35, Y39, PAT750 BAT35, BAT750	Y46	Y45		
YA40-2NTC-FX	25019918	1	646 kcmil 1600/24 (650 kcmil FLEX)	-----	1/2 [M12]	2.94 [75]	1.98 [50]	1.75 [44]	---	.56 [14]	6.95 [177]	.63 [16]	1.35 [34]	.30 [8]	.64 [16]	24	BLACK	U39RT (4)	U39RT (4)	U39RT (4)	HYDRAULIC: Y644M (1) BAT644M (1) PAT644M (1)	3"	
YA40-2NTC-FX-45	10066947	2																					
YA40-2NTC-FX-90	10066948	3																					

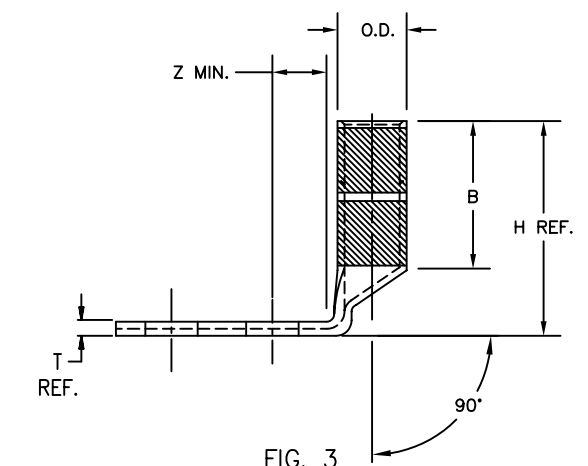
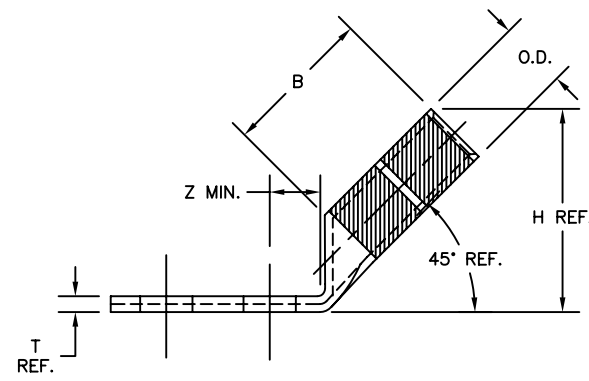
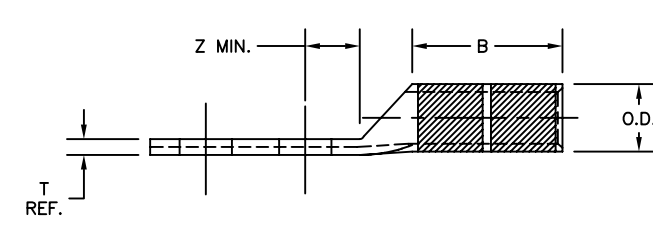
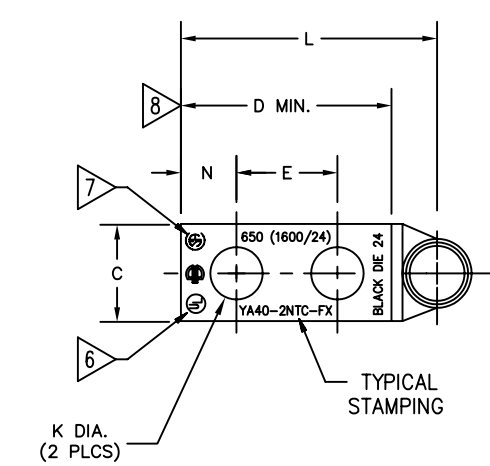
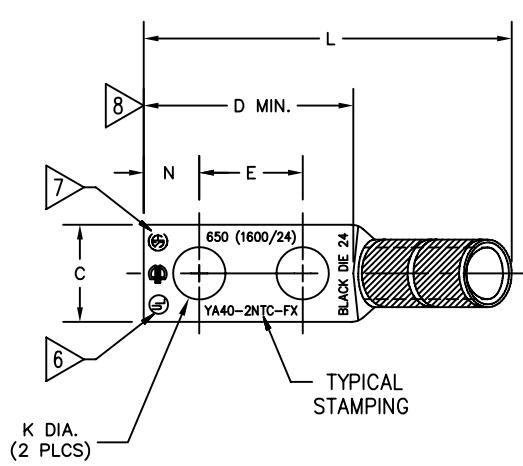
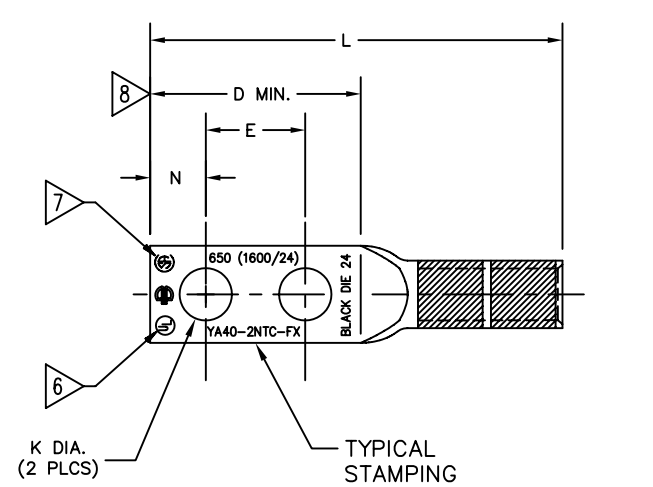

**NOTES:**

1. MATERIAL: COPPER TUBING.
2. FINISH: TIN PLATED.
3. CATALOG # PT6515 ADAPTOR IS REQUIRED TO USE "U" DIES IN Y45 SERIES TOOLS.
4. CATALOG # PUADP-1 ADAPTOR IS REQUIRED TO USE "U" DIES IN Y46 SERIES TOOLS.
5. DIMENSIONS IN BRACKETS [ ] ARE IN MILLIMETERS ROUNDED OFF TO THE NEAREST MILLIMETER, UNLESS OTHERWISE NOTED, AND ARE FOR REFERENCE ONLY.
6. CONNECTORS ARE UL LISTED; UNDRILLED VERSIONS ARE NOT UL LISTED.
7. CONNECTORS ARE CSA CERTIFIED; UNDRILLED VERSIONS ARE NOT CSA CERTIFIED.
8. FOR UNDRILLED VERSIONS ADD SUFFIX "-U" TO END OF CATALOG NUMBER. FOR UNDRILLED VERSIONS, USE D MIN. = N MAX. + E MIN. + Z MIN.

REV.	DATE	DESCRIPTION	ECO	BY	C'K'D.
A	3/14/06	DRAWING RELEASED	12403	RB	PL

TO ORDER BURNDY® PRODUCTS CALL UNITED STATES: 1-800-346-4175 (LONDONDERRY, NH) CANADA: 1-800-361-6975 (QUEBEC) 1-800-387-6487 (ALL OTHER PROVINCES) FOR PRODUCT INFO: <a href="http://www.burndy.com">http://www.burndy.com</a>		HYLUG™	
		ITEM NO: (TABLE)	
CAT NO: YA40-2NTC-FX, -45 & -90		SCALE: NTS	
DRAWN BY: R BOISVERT 03/14/06			
CHECKER: P LAPONIUS 03/15/06			
DSN APPVL: J MICHAUD 03/13/06		DRAWING NO	
MFG APPVL: ---		10066496	
QC APPVL: J BRODEUR 03/13/06		REV	
MKT APPVL: J SYLVIA 03/12/06		A	
PROD FAM: ---		SHEET 1 OF 1	
PROJECT #: ---		SIZE	
DOCUMENT TYPE: Sales		D	
REL LEVEL: AutoCAD			