

DRAWING NO. <b>10067787</b>		4		3		2		1			
CATALOG NUMBER	CONDUCTOR		BOLT SIZE	DIE INDEX	COLOR CODE	INSTALLATION TOOLING (# CRIMPS)				DIELESS (# CRIMPS)	WIRE STRIP LENGTH
	FLEX	CODE (AWG)				MECHANICAL	HYDRAULIC				
YAG31LTC12FXG1NK	250 kcmil 637/24 CLASS I, K, M	---	1/2 [M12]	17	WHITE	MD7-34R	Y750, Y35, Y39 BAT750, PAT750	Y46 $\triangleleft$ 4	Y45 $\triangleleft$ 3		1-1/8"

REV.	DATE	DESCRIPTION	ECO	BY	C'K'D.
B	10/13/06	ADD PAT 600 18V AND W30RT (2)	13126	RB	PL

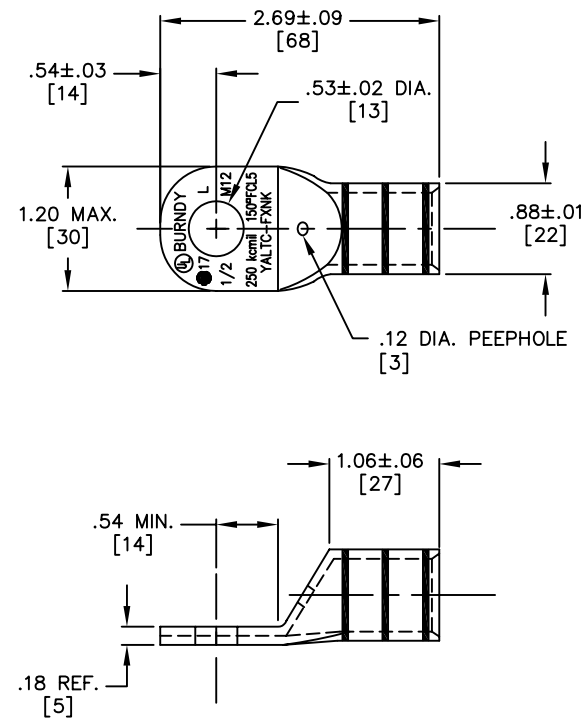

**NOTES:**

1. MATERIAL: COPPER TUBING.
2. FINISH: NICKEL PLATED.
- $\triangleleft$ 3 CATALOG # PT6515 ADAPTOR IS REQUIRED TO USE "U" DIES IN Y45 SERIES TOOLS.
- $\triangleleft$ 4 CATALOG # PUADP-1 ADAPTOR IS REQUIRED TO USE "U" DIES IN Y46 SERIES TOOLS.
5. DIMENSIONS IN BRACKETS [ ] ARE IN MILLIMETERS, ROUNDED OFF TO THE NEAREST MILLIMETER, UNLESS OTHERWISE NOTED, AND ARE FOR REFERENCE ONLY.

TO ORDER BURNDY® PRODUCTS CALL 1-800-346-4175 MANCHESTER, NH 03109, USA FOR PRODUCT INFO = <a href="http://www.burndy.com">http://www.burndy.com</a>	
HYLUG™	
ITEM NO: 10063814	
CAT NO: YAG31LTC12FXG1NK	
SCALE: 1/1	
DRAWN BY: R. BOISVERT 03/30/08	
CHECKER: P. LAPONUIS 03/30/08	
DSN APPV: J. MICHAUD 03/28/06	
MFG APPV: N/A	
CC APPV: J. BRODEUR 03/29/08	
MKT APPV: J. SILVA 03/28/06	
PROJ FAM: ---	DRAWING NO
PROJECT & ---	10067787
DOCUMENT TYPE: Sales	SIZE
REL LEVEL: AutoCAD	C
	SHEET 1 OF 1