

DRAWING NO.  
10069782

NUMÉRO DE CATALOGUE	DESCRIPTION	CONDUCTEUR CONDUCTOR	BASE ET BRIDE (BODY & CAP)		BOULONS (BOLTS)			ÉCROUS (NUTS)			RONDELLES (WASHERS)			COUPLE D'INSTALLATION (INSTALLATION TORQUE)	
			ALLIAGE ALLOY	ALLIAGE ALLOY	DIMENSION	QTY	ALLIAGE ALLOY	DIMENSION	QTY	ALLIAGE ALLOY	DIMENSION	QTY	LB-PO LBS-IN	N.m.	
N2AH4444NHO	RACCORD CU BOULONNÉ 2 CABLES À PLAQUE BOLTED CU TERMINAL 2 CABLES TO FLAT	4/0 STR(.529) 1000 Kcmil(1.152)	ALLIAGE DE CUIVRE COULÉ	BRONZE SILICIUM	1/2-13 X 2.25 [13 X 57]	8	BRONZE SILICIUM	1/2" [13]	8	BRONZE SILICIUM	1/2" [13]	8	480	54	

REV	DATE	DESCRIPTION	ECO	BY	C'H'K.
E	12/23/2009 2:11:00 AM	CHANGED BOLTS PER MARKUP BOLTS ARE SHORT	19936	NJS	RL

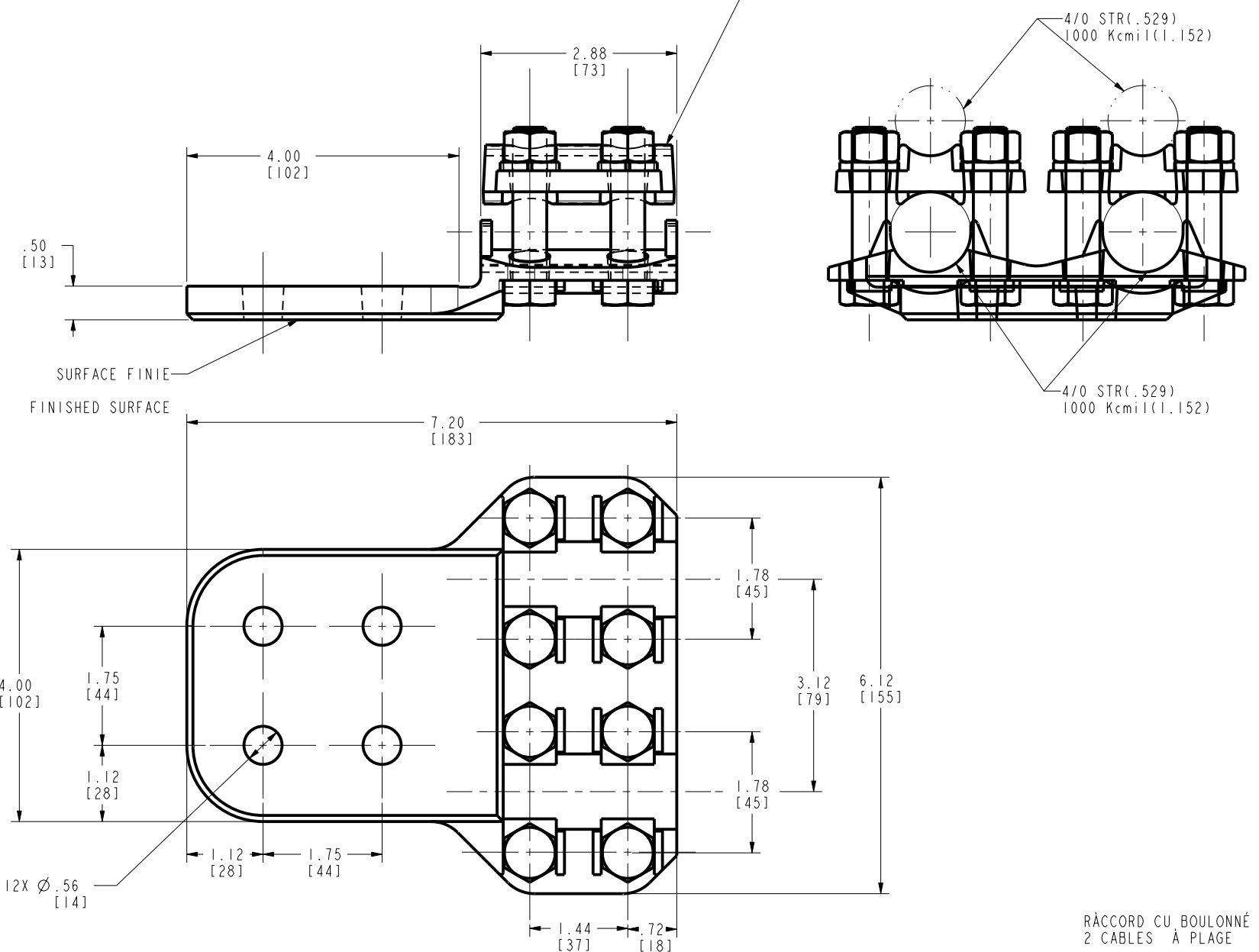

REVERSIBLE CAP USED FOR ACCOMMODATING A WIDE RANGE OF CONDUCTORS.  
CAPOT REVERSIBLE POUR ACCOMMODER UNE LARGE GAMME DE CONDUCTEURS.

NOTES:

- MATÉRIEL:  
CORPS ET BRIDE: ALLIAGE DE CUIVRE COULÉ.
- LES DIMENSIONS ENTRE CROCHETS [ ] INDIQUENT LES UNITÉS MÉTRIQUES ET SONT ARRONDIES LE PLUS PRÈS DU NOMBRE EXACT. À MOINS D'AVIS CONTRAIRE, CES UNITÉS SONT UTILISÉES POUR RÉFÉRENCE SEULEMENT.
- LES CHANGEMENTS EFFECTUES SUR CE DESSIN SUIVENT LES PROCESSUS QUI SONT DOCUMENTÉS DANS LA PROCÉDURE D'ASSURANCE QUALITE DE FCI PROCÉDURE NO.04.3, PARAGRAPHE 6.4 "AVIS AU CLIENT D'UN CHANGEMENT TECHNIQUE".

NOTES:

- MATERIAL:  
BODY & CAP: CAST COPPER ALLOY
- DIMENSIONS IN BRACKETS [ ] DENOTES METRIC UNITS [SI UNITS] AND ARE ROUNDED TO THE NEAREST WHOLE NUMBER. UNLESS OTHERWISE SPECIFIED THESE UNITS SHALL BE USED FOR REFERENCE ONLY.
- CHANGES TO THIS DRAWING SHALL FOLLOW THE PROCESS DOCUMENTED IN "THE FCI" QUALITY ASSURANCE PROCEDURE Q4.3 PARAGRAPH 6.4 "CUSTOMER NOTIFICATION OF AN ENGINEERING CHANGE".

RACCORD CU BOULONNÉ  
2 CABLES À PLAGE

TO ORDER BURNDY® PRODUCTS CALL		BOLTED CU TERMINAL-2 CABLES TO FLAT	
UNITED STATES 1-800-346-4175 (LONDONDERRY, NH)		ITEM NO: --	SCALE: 1:1
CANADA: 1-800-361-6975 (QUEBEC) 1-800-387-6487 (ALL OTHER PROVINCES)		CAT. NO: N2AH4444NHO	REV
FOR PRODUCT INFO: <a href="http://www.burndy.com">http://www.burndy.com</a>		DRAWN BY: NJ SUDHAKAR 09/12/06	10069782
		CHECKER: R LAVOIE 12/23/09	E
		DSN APPVL: R LAVOIE 12/23/09	
		MFG APPVL: G KELLY 12/23/09	
		QA APPVL: J HILLMAN 01/07/09	
		MKT APPVL: S MOIST 12/23/09	
		PROJ #:	
		SIZE:	
		DOCUMENT TYPE: Sales	
		REL LEVEL: Released	

REV: PE0200