

REV	DATE	DESCRIPTION	ECO	BY	C.H.K.
B	2017-11-07 00:00:00 EST	FORMAT CHANGE	47995	JP	MB

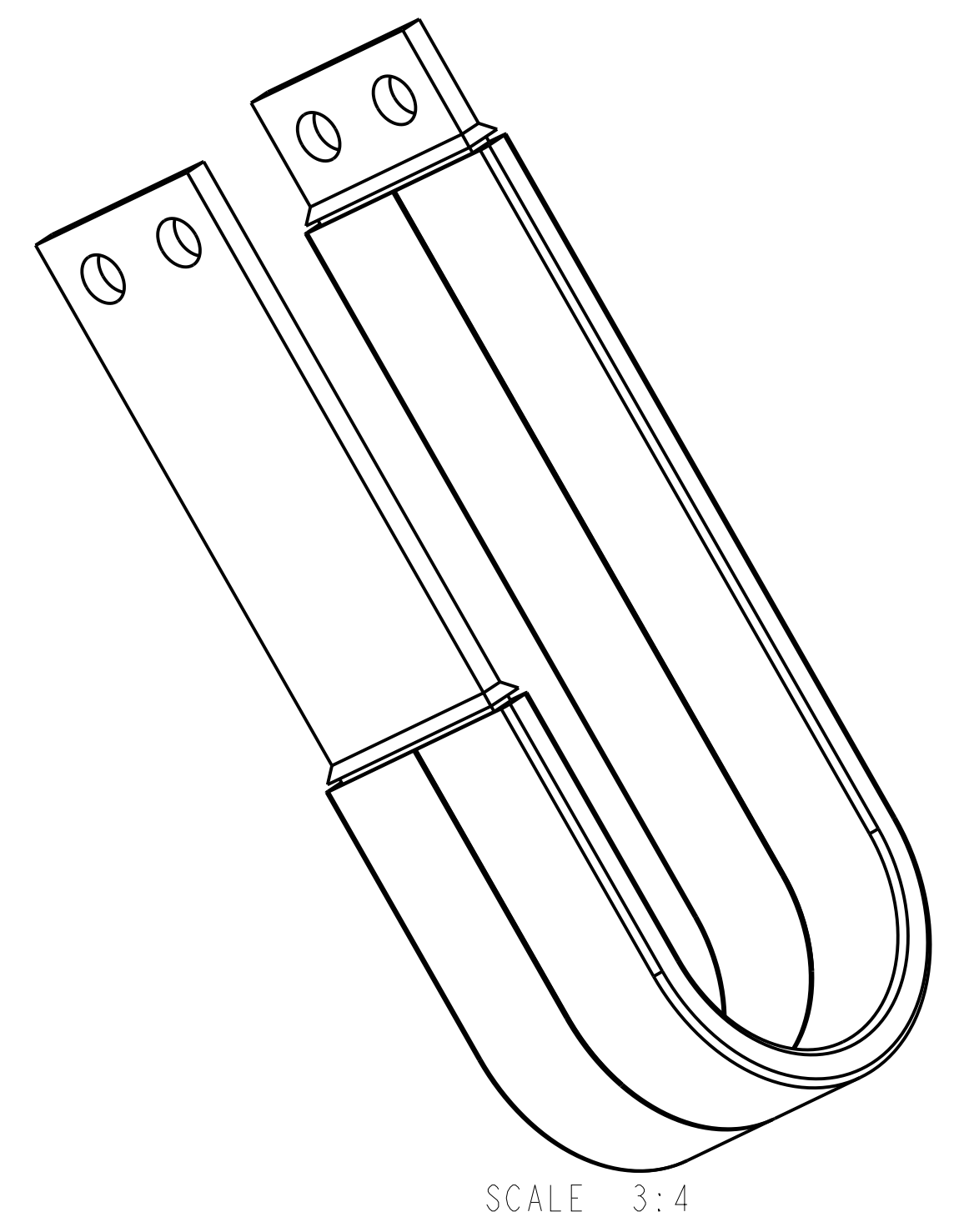
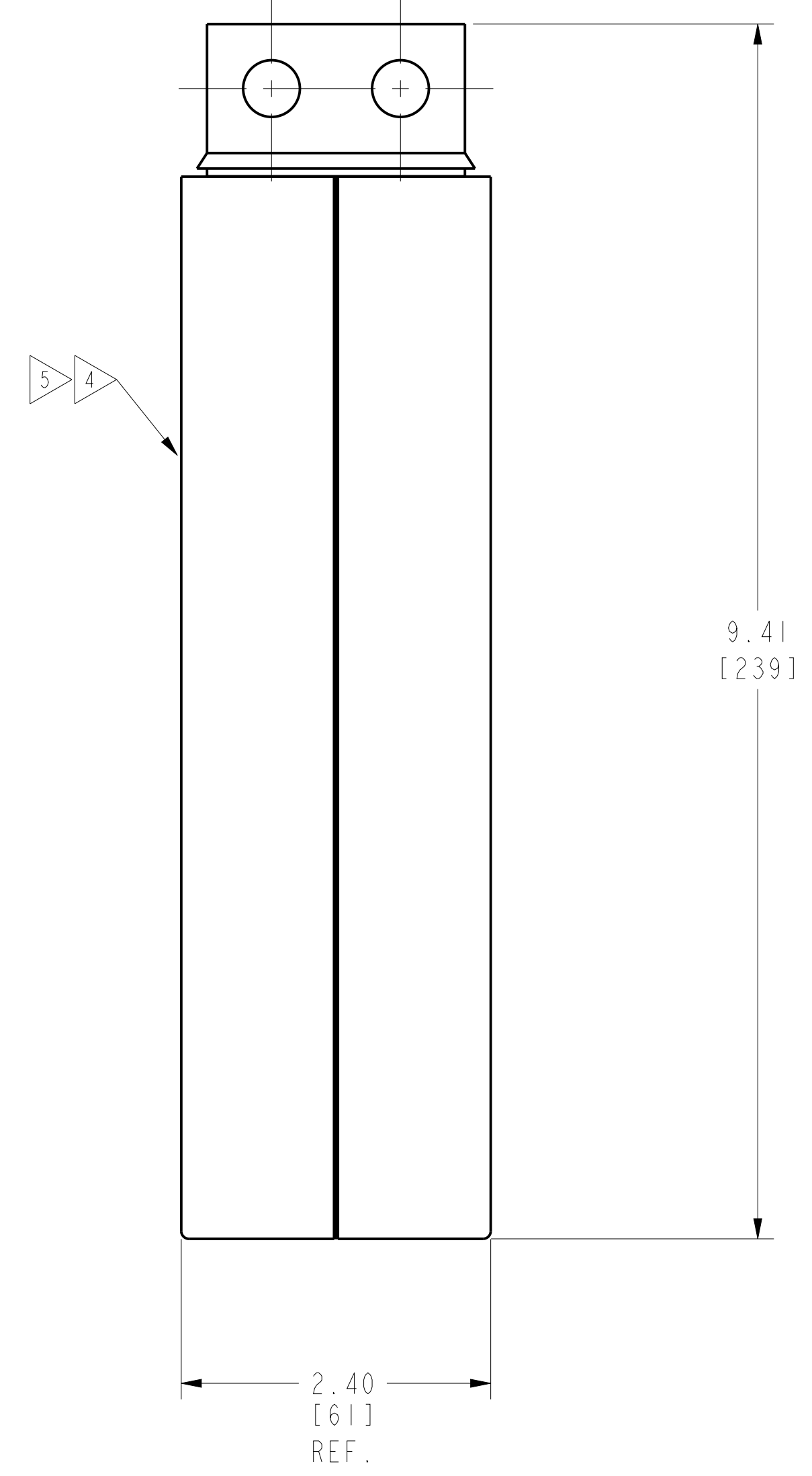
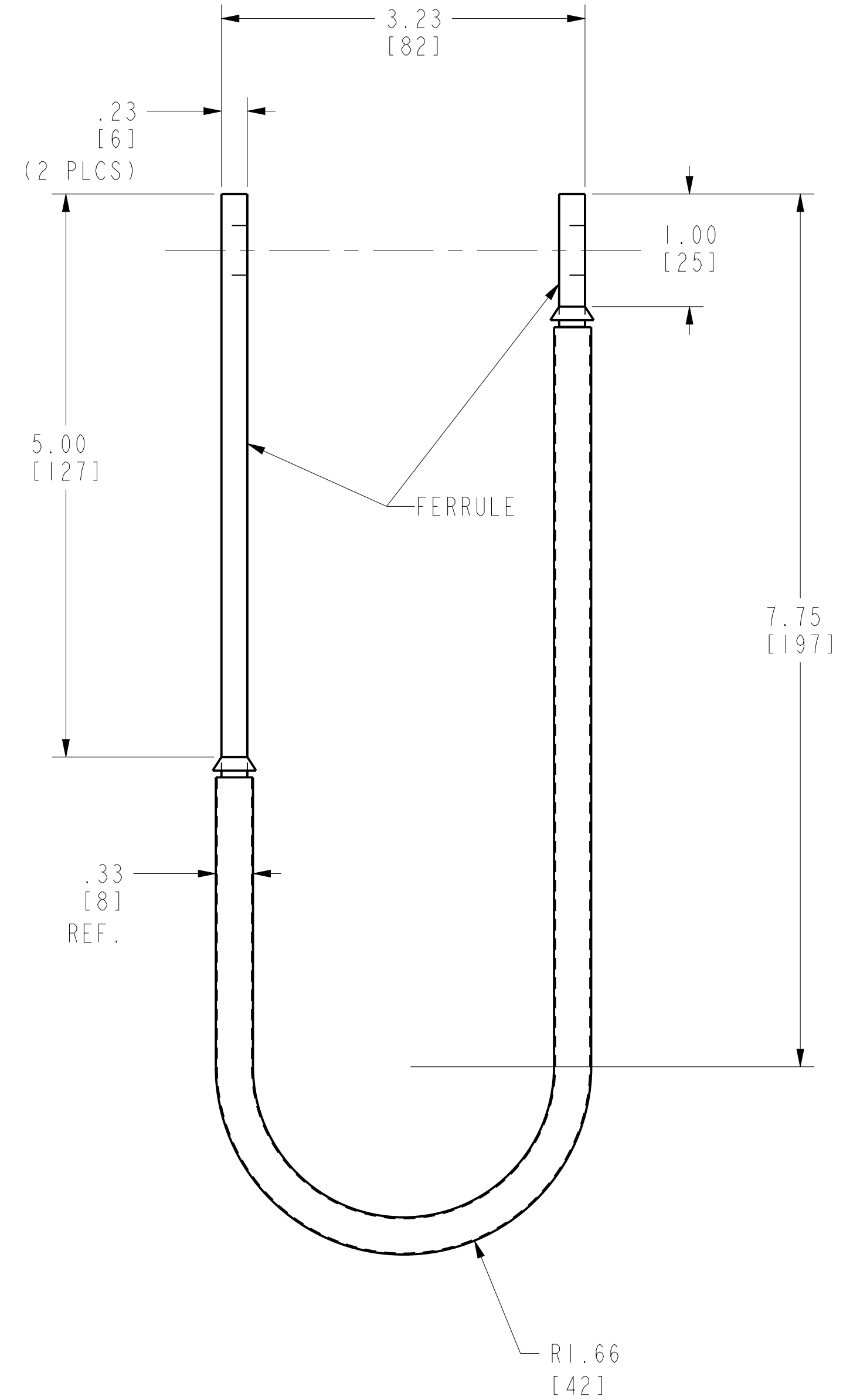
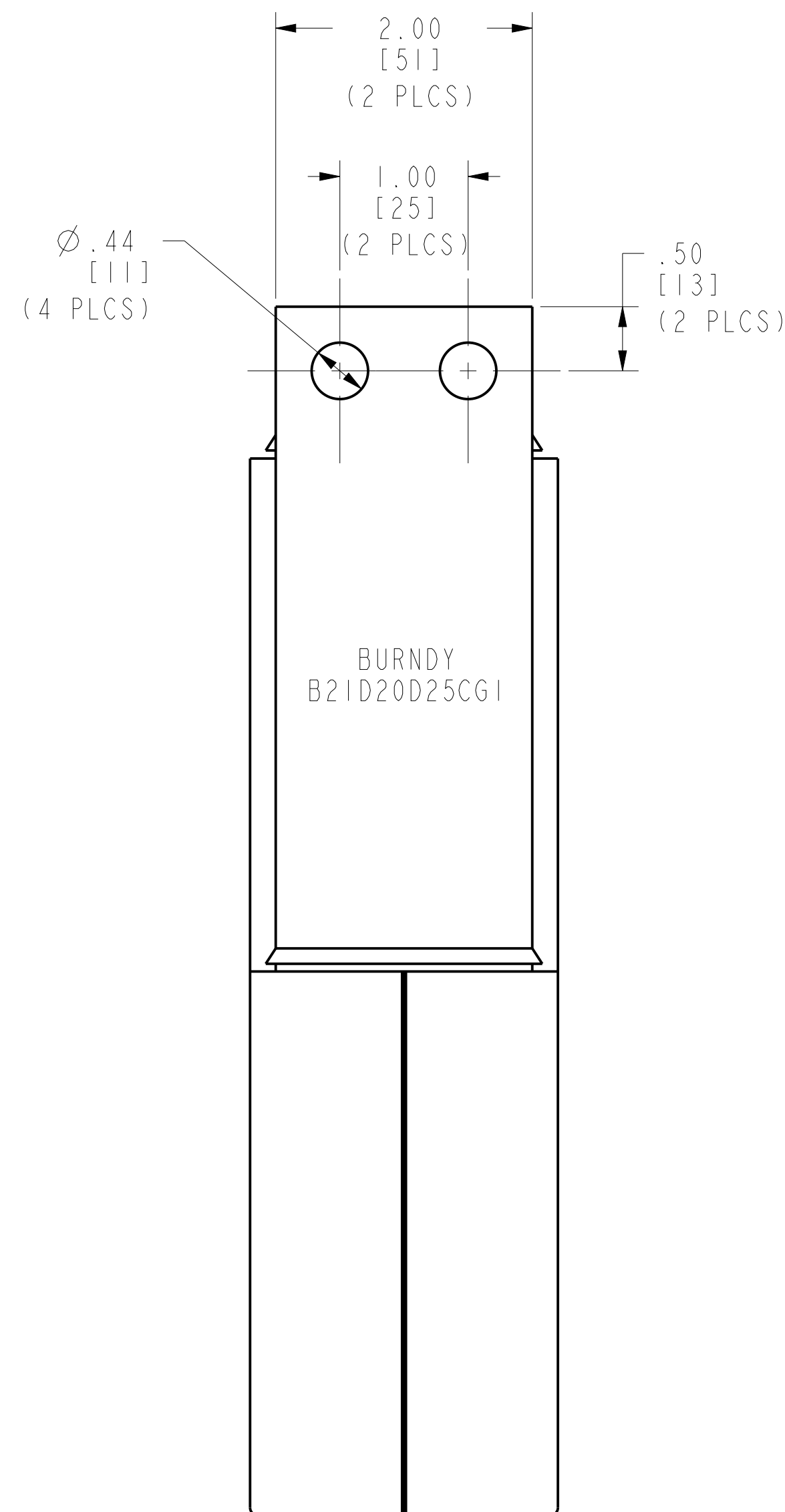

NOTES:

- MATERIAL:
FERRULE, ETP COPPER, TIN PLATED
BRAID, COPPER, 24X32X30, 2 PCS, TIN PLATED
INSULATION, GREY PLASTISOL (U.V. STABILIZED)
- RATING: 304 Amp INDOOR, 364 Amp OUTDOOR. THIS RATING MAY VARY WITH AMBIENT CONDITIONS, ORIENTATION OF THE BRAID, AND OTHER SERVICE CONDITIONS.
- MAXIMUM OPERATION TEMPERATURE FOR THE PLASTISOL INSULATION = 105°
- BRAID SHALL BE PRETENSIONED SO THAT IT WILL ASSUME THE SHAPE DEPICTED NATURALLY.
- PLASTISOL COATING TO BE .10" THK AROUND EACH BRAID.
- DIMENSIONS IN BRACKETS [] ARE IN MILLIMETERS ROUNDED OFF TO THE NEAREST MILLIMETER UNLESS OTHERWISE SPECIFIED, AND ARE FOR REFERENCE ONLY.

TO ORDER BURNDY® PRODUCTS CALL		GND BRAID, 262 KCMIL, U-SHAPE	
UNITED STATES 1-800-346-4175 (LONDONDERRY, NH)		ITEM NO: 10081415	BURNDY
CANADA: 1-800-361-6975 (QUEBEC) 1-800-387-6487 (ALL OTHER PROVINCES)		CAT. NO: B21D20D25CG1	
FOR PRODUCT INFO: http://www.burndy.com		DRAWN BY: B.MICHAUD 10/3/07	
		CHECKER: R.BOISVERT 10/3/07	
		DSN APPVL: J.MICHAUD 10/2/07	
		MFG APPVL: L.LEAVITT 10/2/07	
		QA APPVL: J.BRODEUR 10/3/07	
		MKT APPVL: D.FAN 10/2/07	
		SCALE: 1:1	
		PROJECT #: C0002325	
		SIZE: D	
		DRAWING NO: 10080994	
		REVISION: B	
		SHEET 1 OF 1	

REV: PEO200