

'CATALOG NUMBER OF COMPLETE ASSEMBLY	BODY 1 REQUIRED		CAP ② 1 REQUIRED		① BOLT ③ 1 REQ'D	② NUT ④ 1 REQ'D DWG. DA19274	SPLIT ⑤ LOCKWASHER 1 REQUIRED DWG. DA19274	GAGE PIN	
	PART NO.	DWG. NO.	PART NO.	DWG. NO.	PART NO.	PART NO.	PART NO.	MIN. DIA.	MAX. DIA.
GCM29CG14	--	--	GCM29-P1	10082819	50X200 HEB (DA84327)	50CHEN	50SW	.345	.575

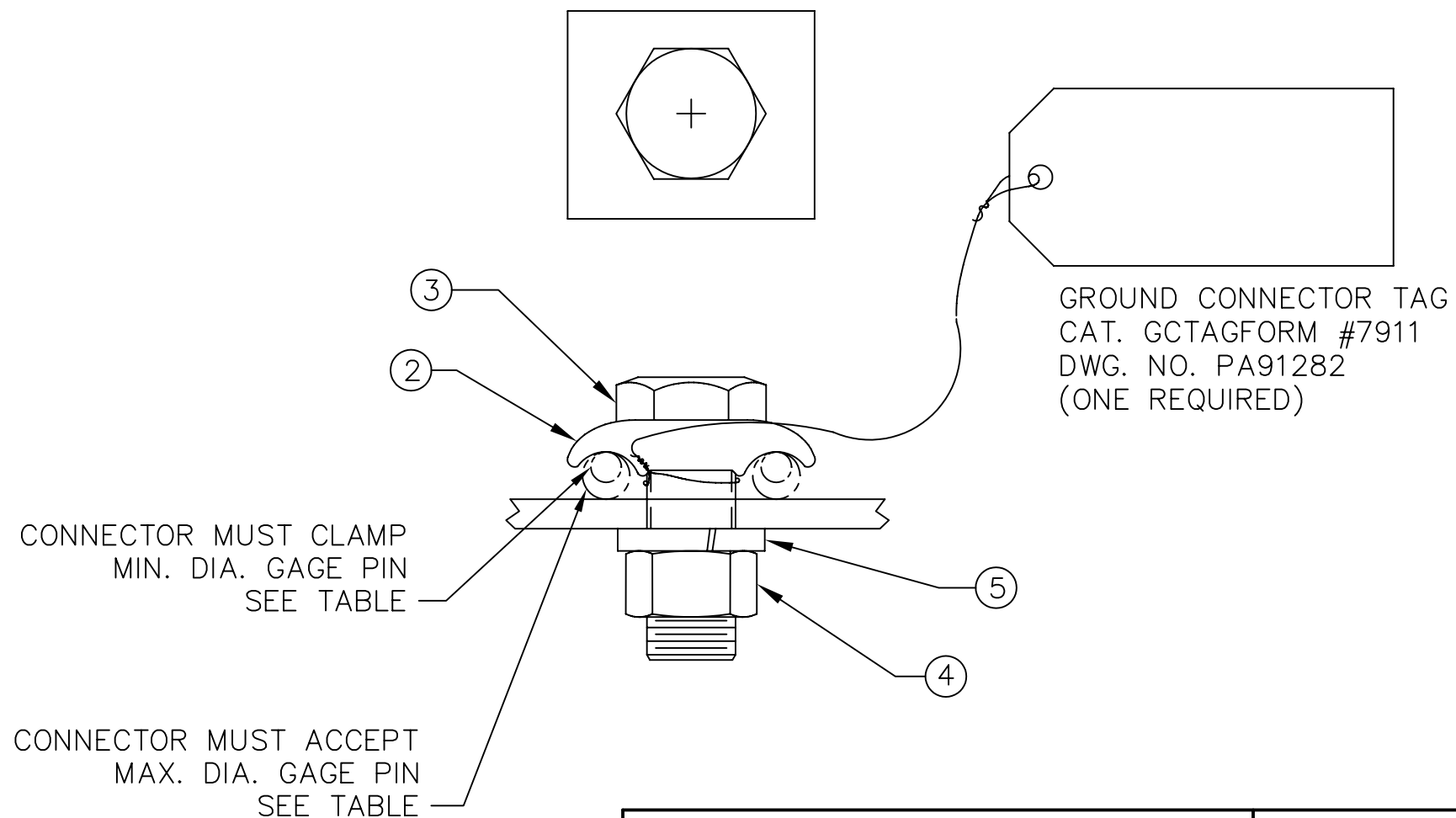

REFERENCE: SC91659  
SC91660

NOTES:

- ① BOLT TO BE IN ACCORDANCE WITH INTERNAL SPEC. H108.
- ② NUT TO BE ACCORDANCE WITH INTERNAL SPEC. H202.

GENERAL NOTES:		GROUND CONNECTOR	
1. ALTHOUGH THIS DRAWING MAY ORIGINALLY HAVE BEEN DEVELOPED TO SCALE, THE USE OF ELECTRONIC DESIGN AND REPRODUCTION TECHNIQUES MAY RESULT IN THIS COPY NOT BEING TO SCALE. THEREFORE, DO NOT SCALE THIS PRINT.  2. THE DIMENSIONS, TOLERANCES AND SPECIFICATIONS OF THIS DESIGN ARE GIVEN TO PROVIDE A DEFINITION OF THE FUNCTIONAL REQUIREMENTS FOR THIS COMPONENT OR PRODUCT. ANY PART NOT MEETING THESE REQUIREMENTS SHALL BE CONSIDERED AS SCRAP.		ITEM NO: 27019012	
		CAT NO: CGM29CG14	
THIS DRAWING AND/OR SPECIFICATION IS THE PROPERTY OF FCI USA, INC., MANCHESTER NH 03109 USA. IT IS ISSUED IN STRICT CONFIDENCE AND SHALL NOT BE REPRODUCED, OR COPIED, OR DISCLOSED TO OTHERS, OR USED AS THE BASIS FOR THE MANUFACTURE OR SALE OF APPARATUS WITHOUT THE PERMISSION OF THE OWNER.		SCALE: NTS	
		DRAWN BY: R.BOISVERT 10/22/07	
		CHECKER: P. LAPONIUS 10/23/07	
		DSN APPVL: M. RZASA 10/04/07	
		MFG APPVL: T.THRELFALL 10/10/07	
		QC APPVL: J. BRODEUR 10/08/07	
MKT APPVL: -- --	DRAWING NO	REV	
PROD FAM: --	10082818	A	
PROJECT #: --	SIZE		
DOCUMENT TYPE: Production	B	SHEET 1 of 1	
REL LEVEL: AutoCAD			

REV.	DATE	DESCRIPTION	ECO	BY	C'K'D.
A	10/22/07	DRAWING RELEASED	15040	RB	PL