

REV.	DATE	DESCRIPTION	ECO	BY	C.H.K.
B	05/05/2017 00:00:00 AM	LOGO UPDATED	46675	CV	MB

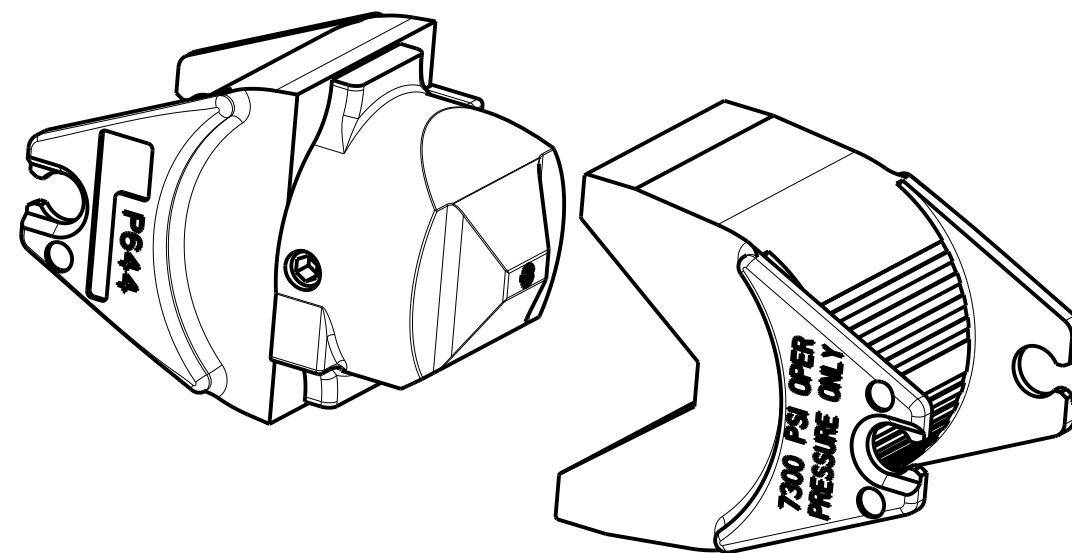

NOTES:

1. THE P644 DIE SET IS DESIGNED FOR USE IN BURNDY® Y460EM11T, Y460EM12T, Y12TOEM, AND Y46 HYPRESS™ TOOLS ONLY AND MUST BE OPERATED AT 11 TONS OF CRIMP FORCE.
2. HYDRAULIC PUMPS TO BE SET TO 7,300 PSI TO ENSURE CORRECT OPERATING FORCE OF 11 TONS FOR THE ABOVE LISTED TOOLS.
3. CRIMP RANGE IS #6 AWG TO 500 KcMIL CODE COPPER AND #6 AWG - 350 KcMIL CODE ALUMINUM.
4. JUST LIKE THE Y644, THE P644 DIE SET PROVIDES FOR UL AND CSA CONNECTIONS WHEN USED WITH BURNDY® TOOLS AND OPERATING PRESSURE AS DESCRIBED ABOVE.
5. THE BURNDY ENGINEERED SYSTEM ALLOWS FOR VISUAL INSPECTABILITY WITH EACH CRIMP BY LOOKING FOR THE BURNDY® BUG "B" EMBOSSEMENT.

TO ORDER BURNDY® PRODUCTS CALL

UNITED STATES:  
1-800-346-4175 (LONDONDERRY, NH)

CANADA:  
1-800-361-6975 (QUEBEC)  
1-800-387-6487 (ALL OTHER PROVINCES)

FOR PRODUCT INFO: <http://www.burndy.com>

DIE SET, P644

ITEM NO: 10090534

CAT. NO: P644

DRAWN BY: T. FAUCHER 07/23/2008  
CHECKER: R. ROBICHEAU 07/23/2008  
DSN APPVL: M. CHIASSON 07/31/2008  
MFG APPVL: S. GONYAW 07/31/2008  
QA APPVL: J. AYER 07/31/2008  
MKT APPVL: R. ROBICHEAU 07/31/2008



PROJECT #:	SIZE	DRAWING NO	REV
13810	B	10090536	B

REL LEVEL: Released

SCALE: 1:1

SHEET 1 OF 1