

D

D

C

C

B

B

A

A

CONDUCTOR ACSS	ITEM NUMBER	CATALOG NUMBER	FIG. NO.	HARDWARE KIT	C	D	(L)	O.D	T	INSTALLATION TOOLING OVERLAP CRIMPS								
										BURNDY [®] HYPRESS [™] & DIE SET		ALCOA PRESS		T & B DIE SET		ACA DIES & PRESS		
										DIE	Y60B	150B	H2H	T&B 21940 TYPE PRESS	60 TON PRESS	100 TON PRESS		
300-336.4 kcmil ACSS	10111063	BYNA32RT15HHT	2	TMH9	3.25 [82.5]	4.5 [114.3]	16.41 [416.8]	1.19 [30.2]	0.75 [19.0]	717	L717	M717	H717	96	--	--		
	10111064	BYNA32RT15HT																
397.5 kcmil ACSS	10111065	BYNA34RT15HHT	2	TMH9	3.25 [82.5]	4.5 [114.3]	16.45 [417.8]	1.30 [33.0]	0.75 [19.0]	719	L719	M719	H719	106	6020AH	10020AH		
	10111066	BYNA34RT15HT																
477 kcmil ACSS	10111067	BYNA36RT15HHT	2	TMH9	3.25 [82.5]	4.5 [114.3]	16.76 [425.7]	1.41 [35.7]	0.75 [19.0]	720	L720	M720	H720	115	--	--		
	50079508	BYNA36RT15HHTSSDN																
	10113625	BYNA36RT15HT																
556.5 kcmil ACSS	10113626	BYNA39RT15HHT	2	TMH9	3.25 [82.5]	4.5 [114.3]	17.12 [434.8]	1.50 [38.1]	0.75 [19.0]	722	L722	M722	H722	125	6024AH	10024AH		
	50079507	BYNA39RT15HHTSSDN																
	10106486	BYNA39RT15HT																
605-666.6 kcmil ACSS	10113628	BYNA43RT15HHT	1	TMH4	3.07 [78.0]	3.95 [100.3]	14.41 [366.0]	1.61 [40.9]	0.36 [9.1]	724	L724	M724	H724	140	--	--		
	10113629	BYNA43RT15HT																
715.5-795 kcmil ACSS	10088949	BYNA45IRT15HHT	1	TMH24	3.22 [81.8]	3.95 [100.3]	15.10 [383.5]	1.80 [45.7]	0.45 [11.4]	725	L725	M725	H725	150	--	--		
	50004917	BYNA45IRT15KIHT		TMH346SS														
	50076701	BYNA45IRT15K2HT		TMH348SS														
	50076702	BYNA45IRT15K3HT		TMH347SS														
	10088947	BYNA45IRT15HT																
900-1113 kcmil 45-7 STR ACSS	10108762	BYNA49RT15HHT	1	TMH24	3.22 [81.8]	3.95 [100.3]	15.14 [384.5]	1.97 [50.0]	0.52 [13.2]	727	L727	M727	H727	161	6030AH	10030AH		
	10108761	BYNA49RT15HT																
1113 54-19 STR -1351.5 kcmil ACSS	10088946	BYNA52RT15HHT	1	TMH9	3.22 [81.8]	3.95 [100.3]	16.81 [427.0]	2.25 [57.2]	0.71 [18.0]	728	L728	M728	H728	189	6036AH	10036AH		
	10084020	BYNA52RT15HT																
1431 kcmil ACSS	10113630	BYNA54RT15HHT	1	TMH9	3.22 [81.8]	3.95 [100.3]	18.22 [462.8]	2.25 [57.2]	0.71 [18.0]	728	L728							
	10113631	BYNA54RT15HT																
1510.5-1590 kcmil ACSS	10113849	BYNA56RT15HHT	1	TMH9	3.44 [87.4]	3.95 [100.3]	17.56 [466.0]	2.50 [63.5]	0.86 [21.8]	729	L729	M729	H729	204	6040AH	10040AH		
	10104943	BYNA56RT15HT																
1780 kcmil ACSS	10113634	BYNA58RT15HHT	1	TMH9	3.47 [88.1]	3.95 [100.3]	18.28 [464.3]	2.50 [63.5]	0.80 [20.3]	735	L735	M735	H735	212,214				
	10113635	BYNA58RT15HT																
2156-2167kcmil ACSS	10113636	BYNA59RT15HHT	1	TMH9	3.57 [90.7]	3.95 [100.3]	17.95 [455.9]	2.50 [63.5]	0.64 [16.3]	735	L735			214	--	--		
	10113637	BYNA59RT15HT																

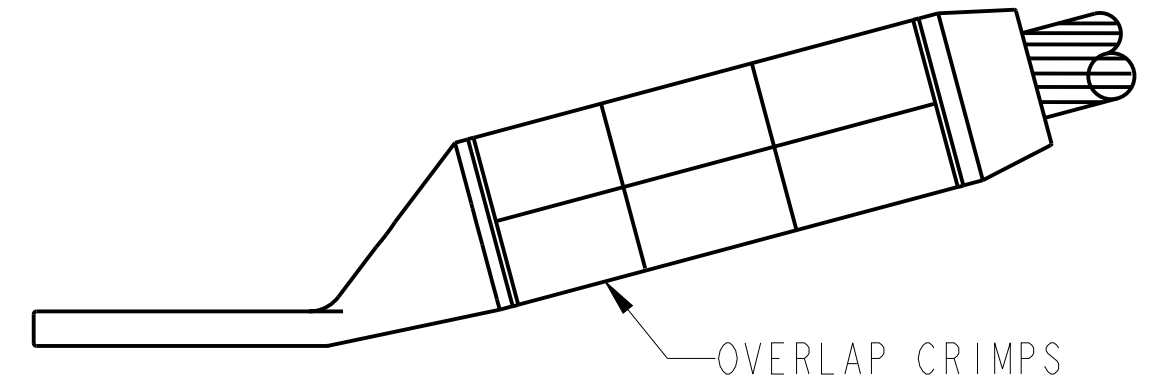

VIEW AFTER INSTALLATION

- NOTES:
- MATERIAL:
 - CONNECTOR, ALUMINUM ALLOY, NO-OX-ID COATED
 - ALUMINUM FILLER PUG
 - HARDWARE
 - BOLTS, ALUMINUM ALLOY (WAX COATED)
 - NUTS AND FLAT WASHERS, ALUMINUM ALLOY
 - RESILIENT WASHERS, GALVANIZED STEEL.
 - DESIGNED FOR CORONA FREE OPERATION TO 230 KV WITH NO ACCESSORIES.
 - RECOMMENDED TORQUE:
1/2" DIA. ALUMINUM BOLTS - 300 IN-LB [34 Nm].
 - FLASH FORMED DURING CRIMPING SHOULD BE REMOVED BY FILLING & SHARP EDGES ROUNDED OFF. THE BARREL PORTION OF THIS CONNECTOR WILL OPERATE QUIETER THAN THE CONDUCTOR AT EXTRA HIGH VOLTAGES.
 - CONNECTOR IS INDIVIDUALLY PACKAGED & SEALED IN POLYTUBE.
 - CONNECTOR SHALL BE SHIPPED UN-ASSEMBLED.
 - PENETROX[™] PENHT IS REQUIRED FOR INSTALLATION. PENETROX[™] PENHT IS NOT PROVIDED WITH THE CONNECTOR AND IS PURCHASED SEPARATELY.
 - INSTALLATION TOOLING IS PURCHASED SEPARATELY.
 - LOCATION AND DATE CODE (B=LOCATION, YY=YEAR, DDD=DAY).
 - INSTALLATION INSTRUCTION FORMI0085255 (10085256)
 - DIMENSIONS IN BRACKETS [] ARE IN MILLIMETERS, AND ARE FOR REFERENCE ONLY.

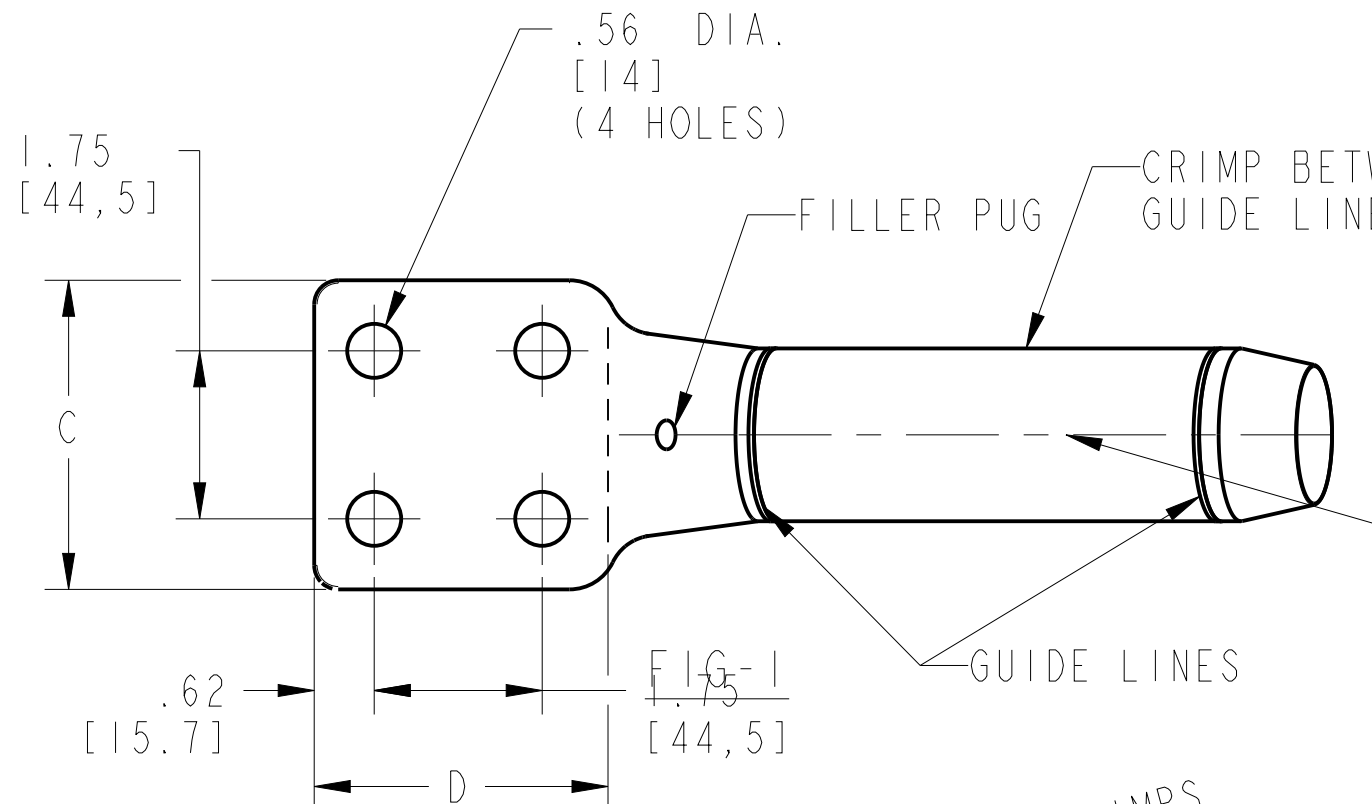

TYPICAL LETTERING
BURNDY
 BYNA45IR/RT 15 HT EHV
 715.5-795 kcmil ACSS
 BYYDD
 OVERLAP CRIMPS
 USE BURNDY DIE 725
 BURNDY PRESS Y60BHU

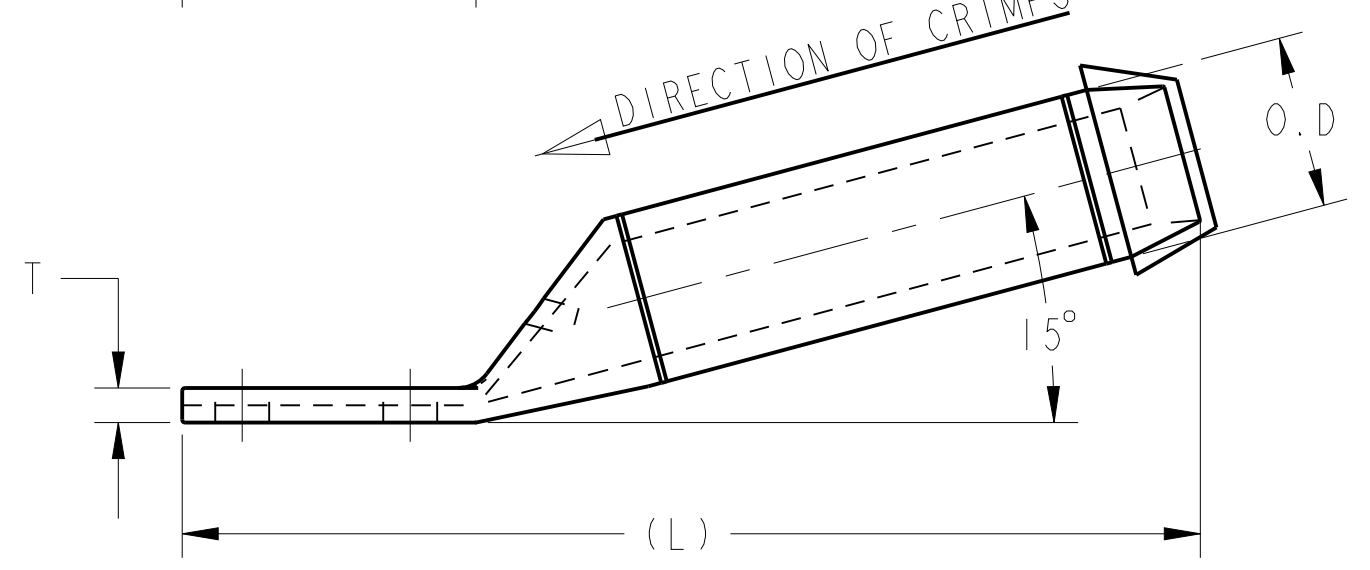
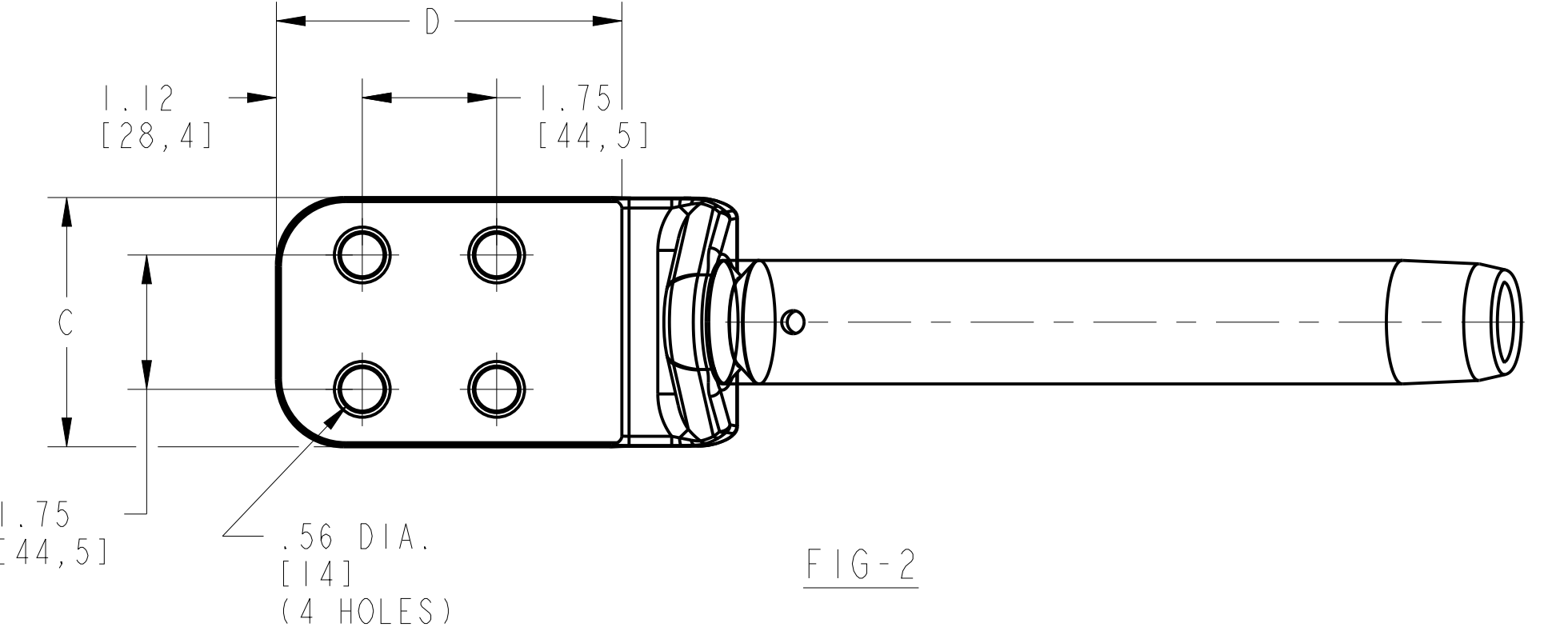

TO ORDER BURNDY[®] PRODUCTS CALL
 UNITED STATES
 1-800-346-4175 (LONDONDERRY, NH)
 CANADA:
 1-800-361-6975 (QUEBEC)
 1-800-387-6487 (ALL OTHER PROVINCES)
 FOR PRODUCT INFO: <http://www.burndy.com>

HYLUG [™] AND HARDWARE			
ITEM NO:	SEE TABLE		
CAT. NO:	SEE TABLE		
DRAWN BY:	D.D.	N/A	
CHECKER:	--	N/A	
DSN APPVL:	P WALTZ	08/02/13	
MFG APPVL:	--	--	
QA APPVL:	C ACKERMAN	08/22/13	
MKT APPVL:	B CRUTCHER	09/04/13	
PROD FAM:	Transmission/YNA, BYNA		SCALE: 0.333
PROJECT #:	--	SIZE	
DOCUMENT TYPE:	Sales		10092588
REL LEVEL:	Released		D



REV: PEO200