

DRAWING NO.  
10099257

REV	DATE	DESCRIPTION	ECO	BY	C'H'K.
1	1/11/2001 12:00:00 AM	FOCUS ITEM# 10094178	17670	BSB	BSK

**NOT FOR PRODUCTION USE**

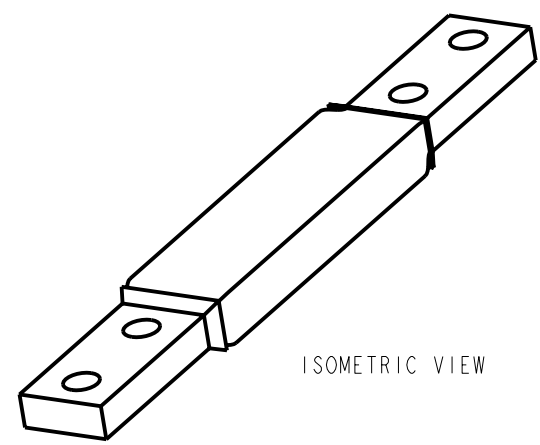
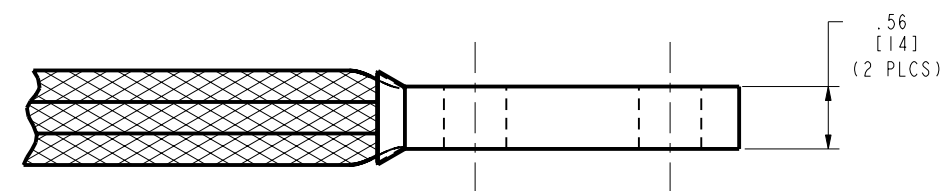
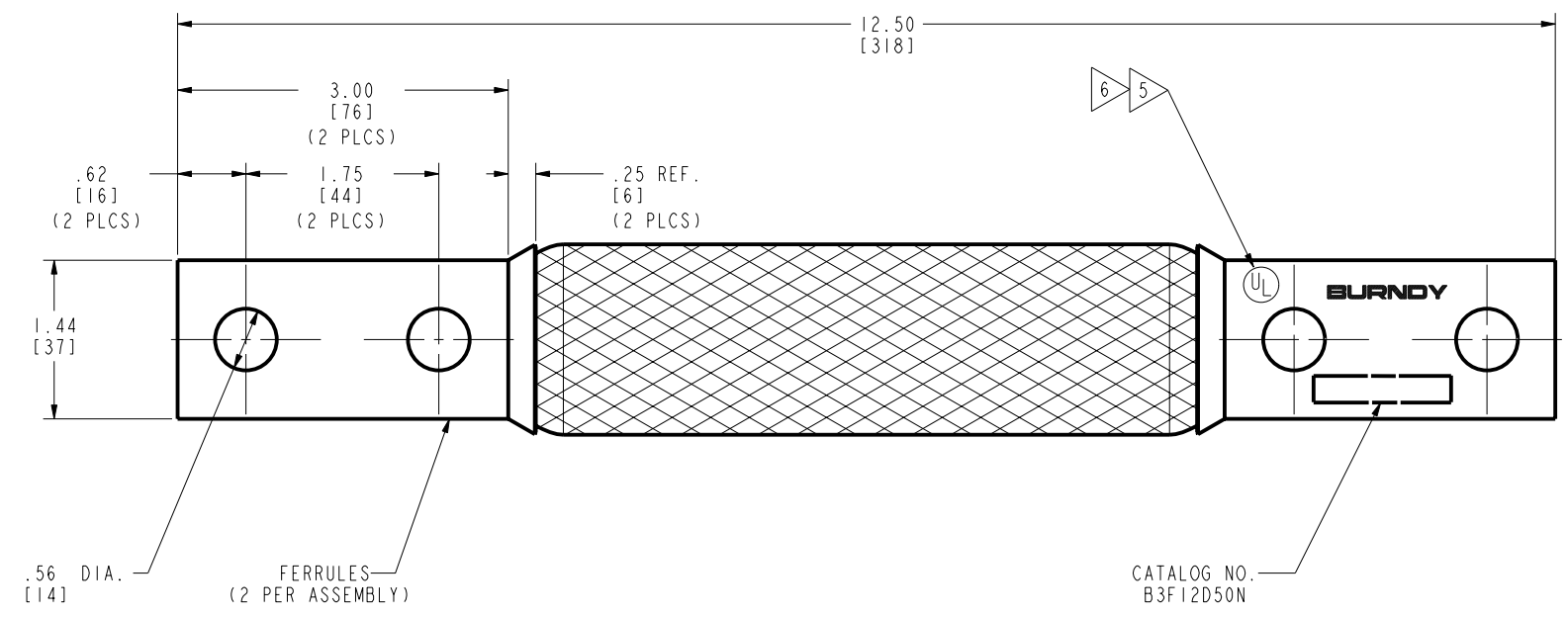

NOTES:

- MATERIAL: FERRULES - COPPER.  
BRAID - TINNED COPPER.
  - FINISH: TINPLATED FERRULES.
  - APPROXIMATE AMP RATING: INDOOR = 820, OUTDOOR = 980.  
THIS RATING MAY VARY WITH AMBIENT CONDITIONS, ORIENTATION OF THE BRAID, AND OTHER SERVICE CONDITIONS.
  - DIMENSION IN BRACKETS [ ] ARE IN MILLIMETERS ROUNDED OFF TO THE NEAREST MILLIMETER, UNLESS OTHERWISE NOTED, AND ARE FOR REFERENCE ONLY.
- 5 ALL SIZES ARE LISTED TO UL 467 GROUNDING & BONDING EQUIPMENT STANDARDS.
- 6 BRAID SIZES MAY BE DESIGNATED BY SUFFIXES REPRESENTING VARIATIONS IN LENGTH, QUANTITY & SIZE OF MOUNTING HOLES, PAD SIZE AND FINISH. (REF. NOTES 5).

TO ORDER BURNDY® PRODUCTS CALL		FLEXIBLE BRAID JUMPER	
UNITED STATES		ITEM NO: 10094178	
1-800-346-4175 (LONDONDERRY, NH)		CAT. NO: B3F12D50NTN	
CANADA:		DRAWN BY: BSB 04/01/2009	
1-800-361-6975 (QUEBEC)		CHECKER: BSK 04/06/2009	
1-800-387-6487 (ALL OTHER PROVINCES)		DSN APPVL: --	
FOR PRODUCT INFO: <a href="http://www.fciconnect.com">http://www.fciconnect.com</a>		MFG APPVL: --	
		QA APPVL: --	
		MKT APPVL: --	
		PROD FAM: --	SCALE: NTS
		PROJECT #: --	DRAWING NO
		DOCUMENT TYPE: Sales	10099257
		REL LEVEL: In Work	REV
			1
			SHEET 1 OF 1

REV: PEO200