

WIRE RANGE				CATALOG NUMBER	CONNECTOR				WIRE STRIP LENGTH		DIMENSIONS		
BARREL A		BARREL B		CLEAR HEAT SHRINK BURNDY® TELECOM KIT LONG BARREL	COLOR CODE		DIE INDEX		BARREL A	BARREL B	TOLERANCES ± .07°		
AWG	MM ²	AWG	MM ²		BARREL A	BARREL B	BARREL A	BARREL B			L		
350 kcmil STR	185 mm ² STR	4/0 AWG FLEX	~ ~ ~		YSR3129FXTEL20	RED	YELLOW	18	16	2.42	2.29	2.51	2.36

REV	DATE	DESCRIPTION	ECO	BY	C.H.K.
B	05/04/2017 13:00:00 PM	LOGO UPDATION	46659	BK	MB

INSTALLATION TOOLING (LONG BARREL)

CATALOG NUMBER	INSTALLATION TOOLING (# CRIMPS)		INSTALLATION TOOLING (# CRIMPS)		INSTALLATION TOOLING (# CRIMPS)		INSTALLATION TOOLING (# CRIMPS)	
CLEAR HEAT SHRINK BURNDY® TELECOM KIT LONG BARREL	HYDRAULIC		HYDRAULIC		MECHANICAL		DIELESS	
	Y750, Y35, Y39, Y45, BAT750 & PAT750		BCT500HS, Y500CTHS		OUR840, MD7-34R		Y644M, Y644MBH, BAT644M, MY29-11, PAT644	
	BARREL A	BARREL B	BARREL A	BARREL B	BARREL A	BARREL B	BARREL A	BARREL B
YSR3129FXTEL20	U31RT (4)	U29RT (4)	W31VT(4) / W31RT(4)	W29VT(4) / W29RT(4) / X29RT(8)	W31VT (4)	W29VT (4) / X29RT (8)	Y644M(2) / PAT644M(2)	Y644M(2) / PAT644M(2)

NOTE: THAT THERE ARE A VARIETY OF BURNDY® INSTALLATION TOOLS AVAILABLE, AND NOT ALL ARE LISTED. IF YOU HAVE QUESTIONS REGARDING TOOLING, PLEASE CONTACT OUR "CUSTOMER SERVICE DEPARTMENT" AT 1-800-346-4175.

KIT		
ITEM	DESCRIPTION	QTY.
A	ELECTRO-TIN PLATED COPPER COMPRESSION CONNECTOR (SEE NOTE 1)	1
B	HEAT SHRINK TUBING (SEE NOTE2)	1
C	MULTILINGUAL INSTALLATION INSTRUCTION SHEET (SEE NOTE3)	1
D	PLASTIC BAG WITH LABELING AND PRODUCT IDENTIFIER	1

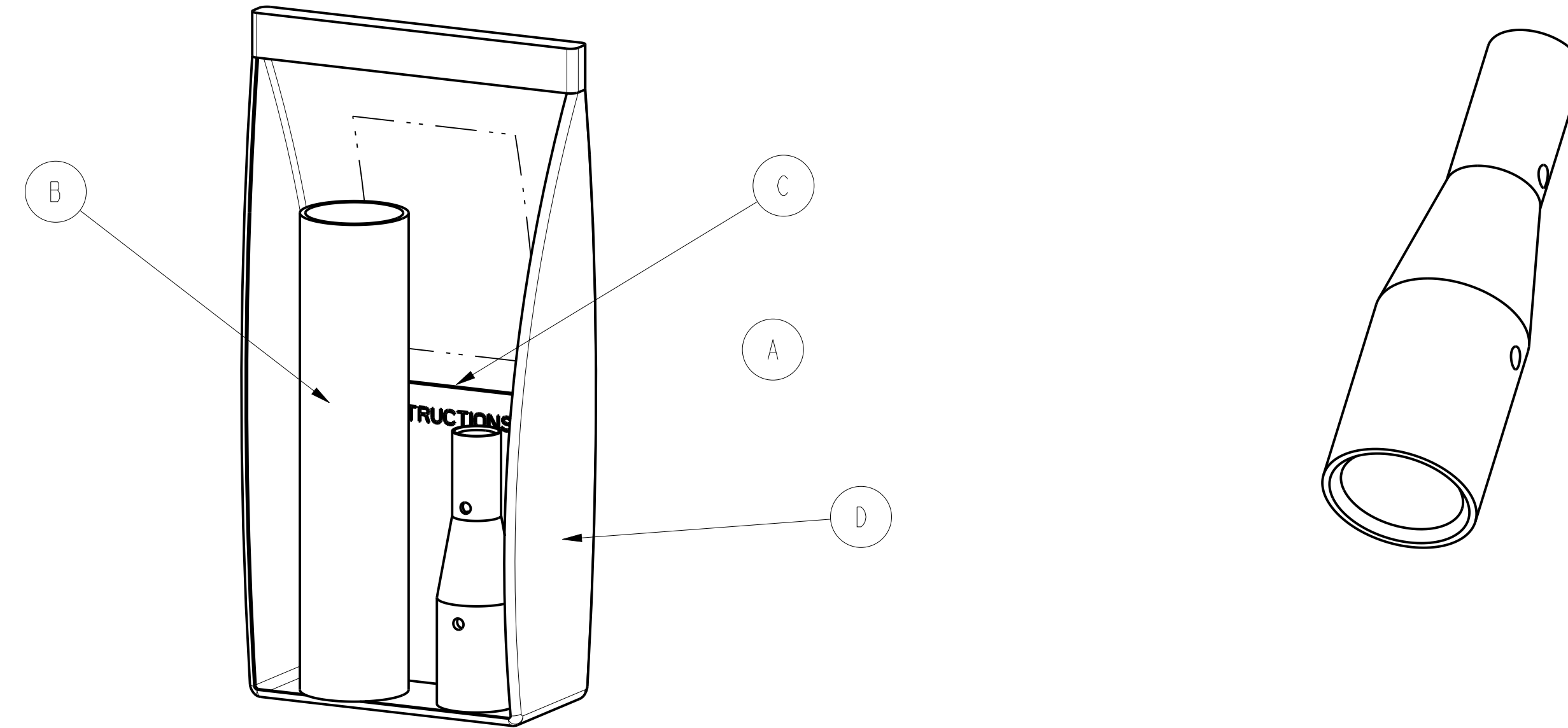

NOTES:

- ELECTRO-TIN PLATED COPPER COMPRESSION REDUCER/SPLICE; WITH A THROUGH HOLE FOR CABLE INSPECTION ON EACH SIDE; COLOR CODE, WIRE STRIP LENGTH AND CRIMP PLACEMENT INDICATIONS ARE INCLUDED. STANDARD BARRELS LISTED UL 486A.
 - HEAT SHRINK TUBING:
 CLEAR - POLYVINYL CHLORIDE - LISTED UL 224, VW-1 RATING. (VERTICAL WIRE FLAME TEST)
 - PASSES TELCORDIA GR-347-CORE "ABRASION TEST".
 - EACH KIT IS PACKED IN A SEALED PLASTIC BAG INCLUDING THE INSTALLATION INSTRUCTIONS IN ENGLISH, FRENCH AND SPANISH.
 - SEE TABLE FOR SPECIFIC KIT CATALOG NUMBER.
 - FOR SPECIFIC APPLICATION TOOLS AND DIES, SEE ABOVE TOOLING TABLE.
- 6 THESE ITEMS WILL BE DEVELOPED IN CONJUNCTION WITH TYCO ELECTRONICS POWER SYSTEMS AND WILL HAVE TYCO MARKINGS ON THEM.

TO ORDER BURNDY® PRODUCTS CALL UNITED STATES 1-800-346-4175 (LONDONDERRY, NH) CANADA: 1-800-361-6975 (QUEBEC) 1-800-387-6487 (ALL OTHER PROVINCES) FOR PRODUCT INFO: http://www.burndy.com	COMPRESSION COPPER REDUCER / SPLICE KIT		
	ITEM NO:	---	
	CAT. NO:	(SEE TABLE)	
	DRAWN BY:	B.SURESH BABU 6/13/09	
	CHECKER:	J.MICHAUD 11/24/09	
	DSN APPVL:	J.MICHAUD 11/24/09	
	MFG APPVL:	---	
	QA APPVL:	J.BRODEUR 11/25/09	
	MKT APPVL:	J.SYLVIA 11/23/09	
	PROD FAM:	CM&R COMPRESSION	DRAWING NO
PROJECT #:	---	SIZE	10101352
DOCUMENT TYPE:	Sales		B
REL LEVEL:	Released	D	SHEET 1 OF 5

WIRE RANGE				CATALOG NUMBER	CONNECTOR				WIRE STRIP LENGTH		DIMENSIONS		
BARREL A		BARREL B		CLEAR HEAT SHRINK BURNDY® TELECOM KIT LONG BARREL	COLOR CODE		DIE INDEX		BARREL A	BARREL B	TOLERANCES ± .07"		
AWG	MM ²	AWG	MM ²		BARREL A	BARREL B	BARREL A	BARREL B			BARREL A	BARREL B	L
350 kcmil FLEX	240 mm ² FLEX	4/0 AWG FLEX	~ ~ ~	YSR34FX29FXTEL24	BLUE	YELLOW	19 OR L80	16	2.67	2.29	2.75	2.36	5.78
500 kcmil STR	240 mm ² STR	350 kcmil FLEX	240 mm ² FLEX	YSR3434FXTEL36	BROWN	BLUE	20	19 OR L80	2.67	2.66	2.75	2.75	5.98
500 kcmil STR	240 mm ² STR	4/0 AWG FLEX	~ ~ ~	YSR3429FXTEL12	BROWN	YELLOW	20	16	2.67	2.29	2.75	2.36	5.78

REV	DATE	DESCRIPTION	ECO	BY	CHK.
B	05/04/2017 13:00:00 PM	LOGO UPDATION	46659	BK	MB

INSTALLATION TOOLING (LONG BARREL)

CATALOG NUMBER	INSTALLATION TOOLING (# CRIMPS)		INSTALLATION TOOLING (# CRIMPS)		INSTALLATION TOOLING (# CRIMPS)		INSTALLATION TOOLING (# CRIMPS)	
CLEAR HEAT SHRINK BURNDY® TELECOM KIT LONG BARREL	HYDRAULIC		HYDRAULIC		MECHANICAL		DIELESS	
	Y750, Y35, Y39, Y45, BAT750 & PAT750		BCT500HS, Y500CTHS		OUR840, MD7-34R		Y644M, Y644MBH, BAT644M, MY29-11, PAT644	
	BARREL A	BARREL B	BARREL A	BARREL B	BARREL A	BARREL B	BARREL A	BARREL B
YSR34FX29FXTEL24	U32RT (4)	U29RT (4)	W32VT(4) / W32RT(4)	W29VT(4) / W29RT(4) / X29RT(8)	W32VT (4)	W29VT (4) / X29RT (8)	Y644M(2) / PAT644M(2)	Y644M(2) / PAT644M(2)
YSR3434FXTEL36	U34RT(2)/U31ART(4)	U32RT (4)	W34VT(4) / W34RT(4)	W32VT(4) / W32RT(4)	W34VT (4)	W32VT (4)	Y644M(2) / PAT644M(2)	Y644M(2) / PAT644M(2)
YSR3429FXTEL12	U34RT(2)/U31ART(4)	U29RT (4)	W34VT(4) / W34RT(4)	W29VT(4) / W29RT(4) / X29RT(8)	W34VT (4)	W29VT (4) / X29RT (8)	Y644M(2) / PAT644M(2)	Y644M(2) / PAT644M(2)

NOTE: THAT THERE ARE A VARIETY OF BURNDY® INSTALLATION TOOLS AVAILABLE, AND NOT ALL ARE LISTED. IF YOU HAVE QUESTIONS REGARDING TOOLING, PLEASE CONTACT OUR "CUSTOMER SERVICE DEPARTMENT" AT 1-800-346-4175.

KIT		
ITEM	DESCRIPTION	QTY.
A	ELECTRO-TIN PLATED COPPER COMPRESSION CONNECTOR (SEE NOTE 1)	1
B	HEAT SHRINK TUBING (SEE NOTE2)	1
C	MULTILINGUAL INSTALLATION INSTRUCTION SHEET (SEE NOTE3)	1
D	PLASTIC BAG WITH LABELING AND PRODUCT IDENTIFIER	1

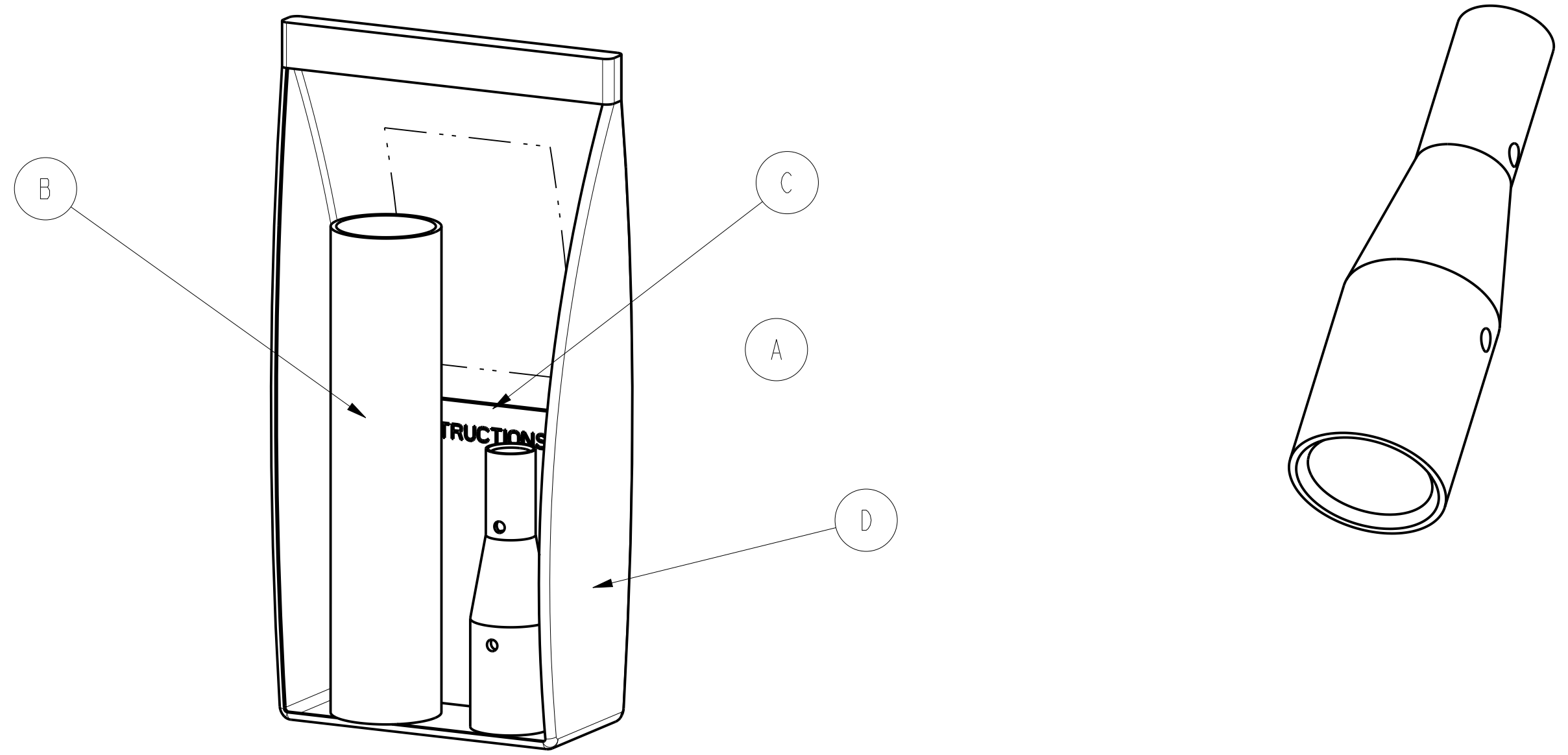

- NOTES:
- ELECTRO-TIN PLATED COPPER COMPRESSION REDUCER/SPLICE; WITH A THROUGH HOLE FOR CABLE INSPECTION ON EACH SIDE; COLOR CODE, WIRE STRIP LENGTH AND CRIMP PLACEMENT INDICATIONS ARE INCLUDED. STANDARD BARRELS LISTED UL 486A.
 - HEAT SHRINK TUBING:
CLEAR - POLYVINYL CHLORIDE - LISTED UL 224, VW-1 RATING. (VERTICAL WIRE FLAME TEST)
- PASSES TELCORDIA GR-347-CORE "ABRASION TEST".
 - EACH KIT IS PACKED IN A SEALED PLASTIC BAG INCLUDING THE INSTALLATION INSTRUCTIONS IN ENGLISH, FRENCH AND SPANISH.
 - SEE TABLE FOR SPECIFIC KIT CATALOG NUMBER.
 - FOR SPECIFIC APPLICATION TOOLS AND DIES, SEE ABOVE TOOLING TABLE.
 - THESE ITEMS WILL BE DEVELOPED IN CONJUNCTION WITH TYCO ELECTRONICS POWER SYSTEMS AND WILL HAVE TYCO MARKINGS ON THEM.

TO ORDER BURNDY® PRODUCTS CALL		COMPRESSION COPPER REDUCER / SPLICE KIT	
UNITED STATES 1-800-346-4175 (LONDONDERRY, NH)		ITEM NO: --	SCALE: 1:1
CANADA: 1-800-361-6975 (QUEBEC) 1-800-387-6487 (ALL OTHER PROVINCES)		CAT. NO: (SEE TABLE)	BURNDY
FOR PRODUCT INFO: http://www.burndy.com		DRAWN BY: B.SURESH BABU 6/13/09	
		CHECKER: J.MICHAUD 11/24/09	PROJECT #: --
		DSN APPVL: J.MICHAUD 11/24/09	SIZE: D
		MFG APPVL: --	10101352
		QA APPVL: J.BRODEUR 11/25/09	B
		MKT APPVL: J.SYLVIA 11/23/09	SHEET 2 OF 5
		PROD FAM: CM&R COMPRESSION	
		DOCUMENT TYPE: Sales	
		REL LEVEL: Released	

REV: PEO200

WIRE RANGE				CATALOG NUMBER	CONNECTOR				WIRE STRIP LENGTH		DIMENSIONS		
BARREL A		BARREL B		CLEAR HEAT SHRINK BURNDY® TELECOM KIT LONG BARREL	COLOR CODE		DIE INDEX		BARREL A	BARREL B	TOLERANCES ± .07"		
AWG	MM ²	AWG	MM ²		BARREL A	BARREL B	BARREL A	BARREL B			BARREL A	BARREL B	L
500 kcmil FLEX	300 mm ² FLEX	350 kcmil FLEX	240 mm ² STR	YSR38FX34FXTEL40	PINK	BLUE	L99	19 OR L80	2.93	2.66	3.03	2.75	6.27
500 kcmil FLEX	300 mm ² FLEX	470 AWG FLEX	~ ~ ~	YSR38FX29FXTEL16	PINK	YELLOW	L99	16	2.93	2.29	3.03	2.36	6.55

REV	DATE	DESCRIPTION	ECO	BY	C.H.K.
B	05/04/2017 13:00:00 PM	LOGO UPDATION	46659	BK	MB

INSTALLATION TOOLING (LONG BARREL)

CATALOG NUMBER	INSTALLATION TOOLING (# CRIMPS)		INSTALLATION TOOLING (# CRIMPS)		INSTALLATION TOOLING (# CRIMPS)		INSTALLATION TOOLING (# CRIMPS)	
CLEAR HEAT SHRINK BURNDY® TELECOM KIT LONG BARREL	HYDRAULIC		HYDRAULIC		MECHANICAL		DIELESS	
	Y750, Y35, Y39, Y45, BAT750 & PAT750		BCT500HS, Y500CTHS		OUR840, MD7-34R		Y644M, Y644MBH, BAT644M, MY29-11, PAT644	
	BARREL A	BARREL B	BARREL A	BARREL B	BARREL A	BARREL B	BARREL A	BARREL B
YSR38FX34FXTEL40	U38XRT (4)	U32RT (4)	N/A	W32VT(4) / W32RT(4)	N/A	W32VT (4)	Y644M(2) / PAT644M(2)	Y644M(2) / PAT644M(2)
YSR38FX29FXTEL16	U38XRT (4)	U29RT (4)	N/A	W29VT(4) / W29RT(4) / X29RT(8)	N/A	W29VT (4) / X29RT (8)	Y644M(2) / PAT644M(2)	Y644M(2) / PAT644M(2)

NOTE: THAT THERE ARE A VARIETY OF BURNDY® INSTALLATION TOOLS AVAILABLE, AND NOT ALL ARE LISTED. IF YOU HAVE QUESTIONS REGARDING TOOLING, PLEASE CONTACT OUR "CUSTOMER SERVICE DEPARTMENT" AT 1-800-346-4175.

KIT		
ITEM	DESCRIPTION	QTY.
A	ELECTRO-TIN PLATED COPPER COMPRESSION CONNECTOR (SEE NOTE 1)	1
B	HEAT SHRINK TUBING (SEE NOTE2)	1
C	MULTILINGUAL INSTALLATION INSTRUCTION SHEET (SEE NOTE3)	1
D	PLASTIC BAG WITH LABELING AND PRODUCT IDENTIFIER	1

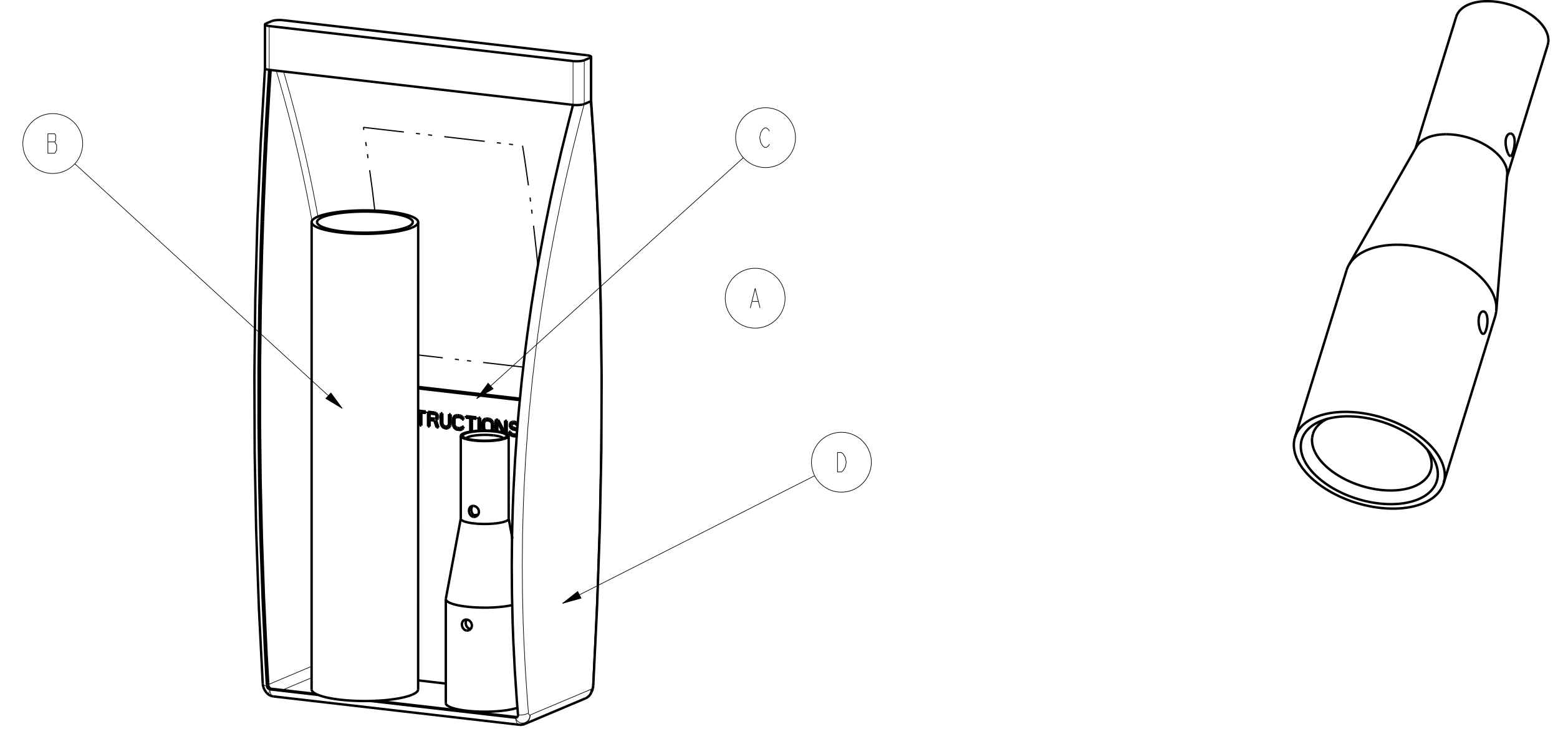

- NOTES:
- ELECTRO-TIN PLATED COPPER COMPRESSION REDUCER/SPLICE; WITH A THROUGH HOLE FOR CABLE INSPECTION ON EACH SIDE; COLOR CODE, WIRE STRIP LENGTH AND CRIMP PLACEMENT INDICATIONS ARE INCLUDED. STANDARD BARRELS LISTED UL 486A.
 - HEAT SHRINK TUBING:
CLEAR - POLYVINYL CHLORIDE - LISTED UL 224, VW-1 RATING. (VERTICAL WIRE FLAME TEST)
- PASSES TELCORDIA GR-347-CORE "ABRASION TEST".
 - EACH KIT IS PACKED IN A SEALED PLASTIC BAG INCLUDING THE INSTALLATION INSTRUCTIONS IN ENGLISH, FRENCH AND SPANISH.
 - SEE TABLE FOR SPECIFIC KIT CATALOG NUMBER.
 - FOR SPECIFIC APPLICATION TOOLS AND DIES, SEE ABOVE TOOLING TABLE.
- 6 THESE ITEMS WILL BE DEVELOPED IN CONJUNCTION WITH TYCO ELECTRONICS POWER SYSTEMS AND WILL HAVE TYCO MARKINGS ON THEM.

TO ORDER BURNDY® PRODUCTS CALL		COMPRESSION COPPER REDUCER / SPLICE KIT	
UNITED STATES 1-800-346-4175 (LONDONDERRY, NH)		ITEM NO: --	SCALE: 1:1
CANADA: 1-800-361-6975 (QUEBEC) 1-800-387-6487 (ALL OTHER PROVINCES)		CAT. NO: (SEE TABLE)	BURNDY
FOR PRODUCT INFO: http://www.burndy.com		DRAWN BY: B.SURESH BABU 6/13/09	
		CHECKER: J.MICHAUD 11/24/09	DRAWING NO
		DSN APPVL: J.MICHAUD 11/24/09	REV
		MFG APPVL: --	10101352
		QA APPVL: J.BRODEUR 11/25/09	B
		MKT APPVL: J.SYLVIA 11/23/09	SHEET 3 OF 5
		PROD FAM: CM&R COMPRESSION	
		PROJECT #: --	
		DOCUMENT TYPE: Sales	
		REL LEVEL: Released	

REV: PEO200

WIRE RANGE				CATALOG NUMBER	CONNECTOR				WIRE STRIP LENGTH		DIMENSIONS		
BARREL A		BARREL B		CLEAR HEAT SHRINK BURNDY® TELECOM KIT LONG BARREL	COLOR CODE		DIE INDEX		BARREL A	BARREL B	TOLERANCES ± .07°		
AWG	MM ²	AWG	MM ²		BARREL A	BARREL B	BARREL A	BARREL B			BARREL A	BARREL B	L
750 kcmil STR	~ ~ ~	500 kcmil FLEX	300 mm ² FLEX	YSR3938FXTEL44	BLACK	PINK	24	L99	2.71	2.93	2.82	3.03	5.99
750 kcmil STR	~ ~ ~	350 kcmil FLEX	240 mm ² STR	YSR3934FXTEL28	BLACK	BLUE	24	19 OR L80	2.71	2.66	2.82	2.75	6.19
750 kcmil STR	~ ~ ~	4/0 AWG FLEX	~ ~ ~	YSR3929FXTEL4	BLACK	YELLOW	24	16	2.71	2.29	2.82	2.36	6.47

REV	DATE	DESCRIPTION	ECO	BY	C.H.K.
B	05/04/2017 13:00:00 PM	LOGO UPDATE	46659	BK	MB

INSTALLATION TOOLING (LONG BARREL)

CATALOG NUMBER	INSTALLATION TOOLING (# CRIMPS)		INSTALLATION TOOLING (# CRIMPS)		INSTALLATION TOOLING (# CRIMPS)		INSTALLATION TOOLING (# CRIMPS)	
CLEAR HEAT SHRINK BURNDY® TELECOM KIT LONG BARREL	HYDRAULIC		HYDRAULIC		MECHANICAL		DIELESS	
	Y750, Y35, Y39, Y45, BAT750 & PAT750		BCT500HS, Y500CHS		OUR840, MD7-34R		Y644M, Y644MBH, BAT644M, MY29-11, PAT644	
	BARREL A	BARREL B	BARREL A	BARREL B	BARREL A	BARREL B	BARREL A	BARREL B
YSR3938FXTEL44	U39RT(2)/P39RT(4)	U38XRT (4)	N/A	N/A	N/A	N/A	Y644M(2) / PAT644M(2)	Y644M(2) / PAT644M(2)
YSR3934FXTEL28	U39RT(2)/P39RT(4)	U32RT (4)	N/A	W32VT(4) / W32RT(4)	N/A	W32VT (4)	Y644M(2) / PAT644M(2)	Y644M(2) / PAT644M(2)
YSR3929FXTEL4	U39RT(2)/P39RT(4)	U29RT (4)	N/A	W29VT(4) / W29RT(4) / X29RT(8)	N/A	W29VT (4) / X29RT (8)	Y644M(2) / PAT644M(2)	Y644M(2) / PAT644M(2)

NOTE: THAT THERE ARE A VARIETY OF BURNDY® INSTALLATION TOOLS AVAILABLE, AND NOT ALL ARE LISTED. IF YOU HAVE QUESTIONS REGARDING TOOLING, PLEASE CONTACT OUR "CUSTOMER SERVICE DEPARTMENT" AT 1-800-346-4175.

KIT		
ITEM	DESCRIPTION	QTY.
A	ELECTRO-TIN PLATED COPPER COMPRESSION CONNECTOR (SEE NOTE 1)	1
B	HEAT SHRINK TUBING (SEE NOTE2)	1
C	MULTILINGUAL INSTALLATION INSTRUCTION SHEET (SEE NOTE3)	1
D	PLASTIC BAG WITH LABELING AND PRODUCT IDENTIFIER	1

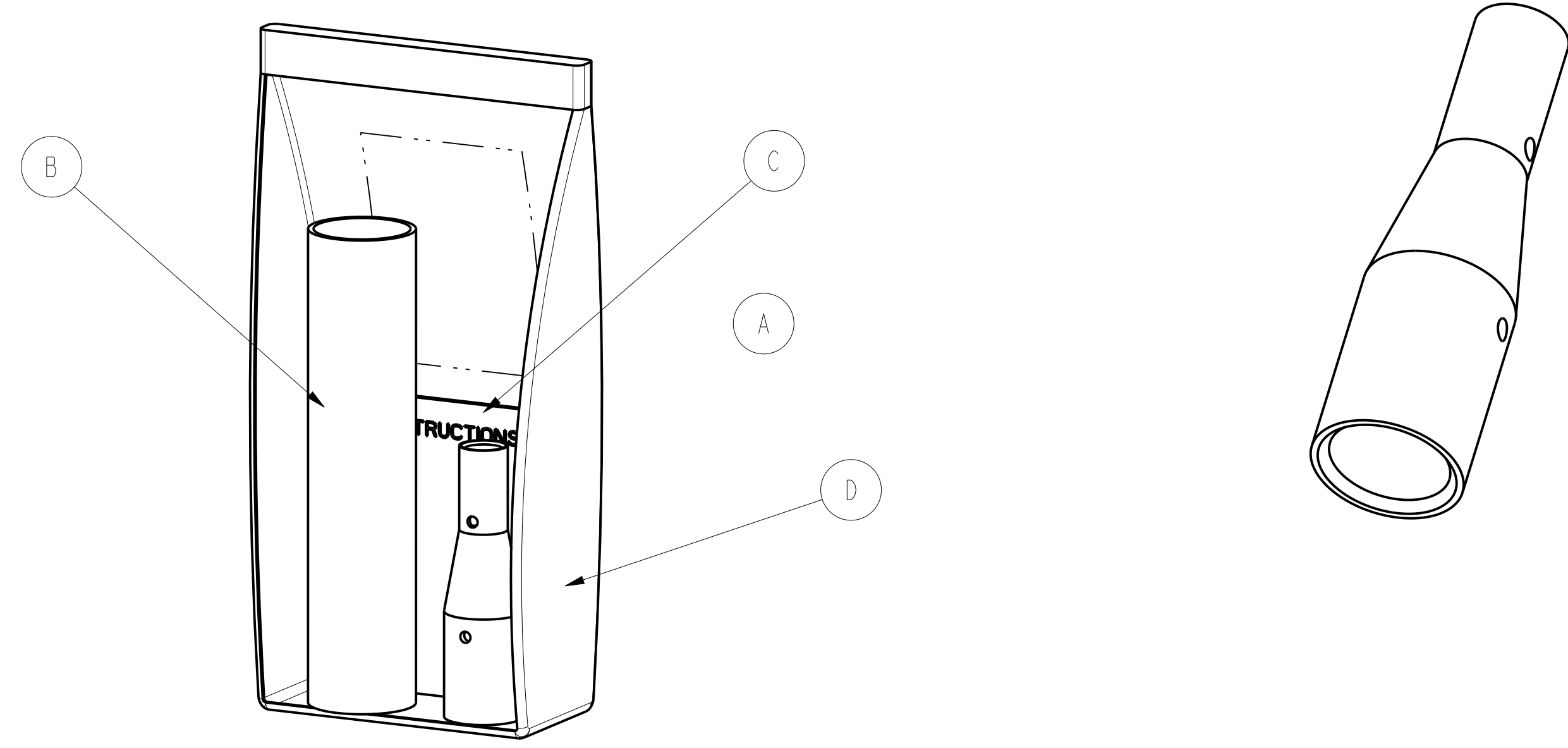

NOTES:

- ELECTRO-TIN PLATED COPPER COMPRESSION REDUCER/SPLICE; WITH A THROUGH HOLE FOR CABLE INSPECTION ON EACH SIDE; COLOR CODE, WIRE STRIP LENGTH AND CRIMP PLACEMENT INDICATIONS ARE INCLUDED. STANDARD BARRELS LISTED UL 486A.
 - HEAT SHRINK TUBING:
CLEAR - POLYVINYL CHLORIDE - LISTED UL 224, VW-1 RATING. (VERTICAL WIRE FLAME TEST)
- PASSES TELCORDIA GR-347-CORE "ABRASION TEST".
 - EACH KIT IS PACKED IN A SEALED PLASTIC BAG INCLUDING THE INSTALLATION INSTRUCTIONS IN ENGLISH, FRENCH AND SPANISH.
 - SEE TABLE FOR SPECIFIC KIT CATALOG NUMBER.
 - FOR SPECIFIC APPLICATION TOOLS AND DIES, SEE ABOVE TOOLING TABLE.
6. THESE ITEMS WILL BE DEVELOPED IN CONJUNCTION WITH TYCO ELECTRONICS POWER SYSTEMS AND WILL HAVE TYCO MARKINGS ON THEM.

TO ORDER BURNDY® PRODUCTS CALL		COMPRESSION COPPER REDUCER / SPLICE KIT	
UNITED STATES 1-800-346-4175 (LONDONDERRY, NH)		ITEM NO: --	SCALE: 1:1
CANADA: 1-800-361-6975 (QUEBEC) 1-800-387-6487 (ALL OTHER PROVINCES)		CAT. NO: (SEE TABLE)	BURNDY
FOR PRODUCT INFO: http://www.burndy.com		DRAWN BY: B.SURESH BABU 6/13/09	
		CHECKER: J.MICHAUD 11/24/09	DRAWING NO
		DSN APPVL: J.MICHAUD 11/24/09	REV
		MFG APPVL: --	10101352
		QA APPVL: J.BRODEUR 11/25/09	B
		MKT APPVL: J.SYLVIA 11/23/09	SHEET 4 OF 5
		PROD FAM: CM&R COMPRESSION	
		PROJECT #: --	
		DOCUMENT TYPE: Sales	
		REL LEVEL: Released	

REV: PEO200

WIRE RANGE				CATALOG NUMBER	CONNECTOR				WIRE STRIP LENGTH		DIMENSIONS		
BARREL A		BARREL B		CLEAR HEAT SHRINK BURNDY® TELECOM KIT LONG BARREL	COLOR CODE		DIE INDEX		BARREL A	BARREL B	TOLERANCES ± .07°		
AWG	MM²	AWG	MM²		BARREL A	BARREL B	BARREL A	BARREL B			L		
750 kcmil FLEX	500 mm² FLEX	500 kcmil FLEX	300 mm² FLEX		YSR44FX38FXTEL48	YELLOW	PINK	L115	L99	3.23	2.93	3.35	3.03
750 kcmil FLEX	500 mm² FLEX	350 kcmil FLEX	240 mm² FLEX	YSR44FX34FXTEL32	YELLOW	BLUE	L115	19 OR L80	3.23	2.66	3.35	2.75	7.23
750 kcmil FLEX	500 mm² FLEX	4/0 AWG FLEX	~ ~ ~	YSR44FX29FXTEL8	YELLOW	YELLOW	L115	16	3.23	2.29	3.35	2.36	7.51

REV	DATE	DESCRIPTION	ECO	BY	CHK.
B	05/04/2017 13:00:00 PM	LOGO UPDATION	46659	BK	MB

INSTALLATION TOOLING (LONG BARREL)

CATALOG NUMBER	INSTALLATION TOOLING (# CRIMPS)		INSTALLATION TOOLING (# CRIMPS)		INSTALLATION TOOLING (# CRIMPS)		INSTALLATION TOOLING (# CRIMPS)	
CLEAR HEAT SHRINK BURNDY® TELECOM KIT LONG BARREL	HYDRAULIC		HYDRAULIC		MECHANICAL		DIELESS	
	Y750, Y35, Y39, Y45, BAT750 & PAT750		BCT500HS, Y500CTHS		OUR840, MD7-34R		Y644M, Y644MBH, BAT644M, MY29-11, PAT644	
	BARREL A	BARREL B	BARREL A	BARREL B	BARREL A	BARREL B	BARREL A	BARREL B
YSR44FX38FXTEL48	U44XRT (4)	U38XRT (4)	N/A	N/A	N/A	N/A	Y644M(2) / PAT644M(2)	Y644M(2) / PAT644M(2)
YSR44FX34FXTEL32	U44XRT (4)	U32RT (4)	N/A	W32VT(4) / W32RT(4)	N/A	W32VT (4)	Y644M(2) / PAT644M(2)	Y644M(2) / PAT644M(2)
YSR44FX29FXTEL8	U44XRT (4)	U29RT (4)	N/A	W29VT(4) / W29RT(4) / X29RT(8)	N/A	W29VT (4) / X29RT (8)	Y644M(2) / PAT644M(2)	Y644M(2) / PAT644M(2)

NOTE: THAT THERE ARE A VARIETY OF BURNDY® INSTALLATION TOOLS AVAILABLE, AND NOT ALL ARE LISTED. IF YOU HAVE QUESTIONS REGARDING TOOLING, PLEASE CONTACT OUR "CUSTOMER SERVICE DEPARTMENT" AT 1-800-346-4175.

KIT		
ITEM	DESCRIPTION	QTY.
A	ELECTRO-TIN PLATED COPPER COMPRESSION CONNECTOR (SEE NOTE 1)	1
B	HEAT SHRINK TUBING (SEE NOTE2)	1
C	MULTILINGUAL INSTALLATION INSTRUCTION SHEET (SEE NOTE3)	1
D	PLASTIC BAG WITH LABELING AND PRODUCT IDENTIFIER	1

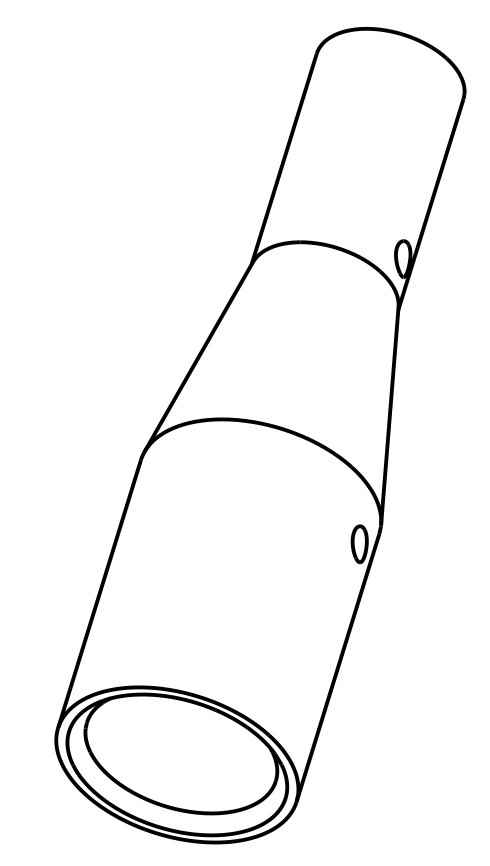
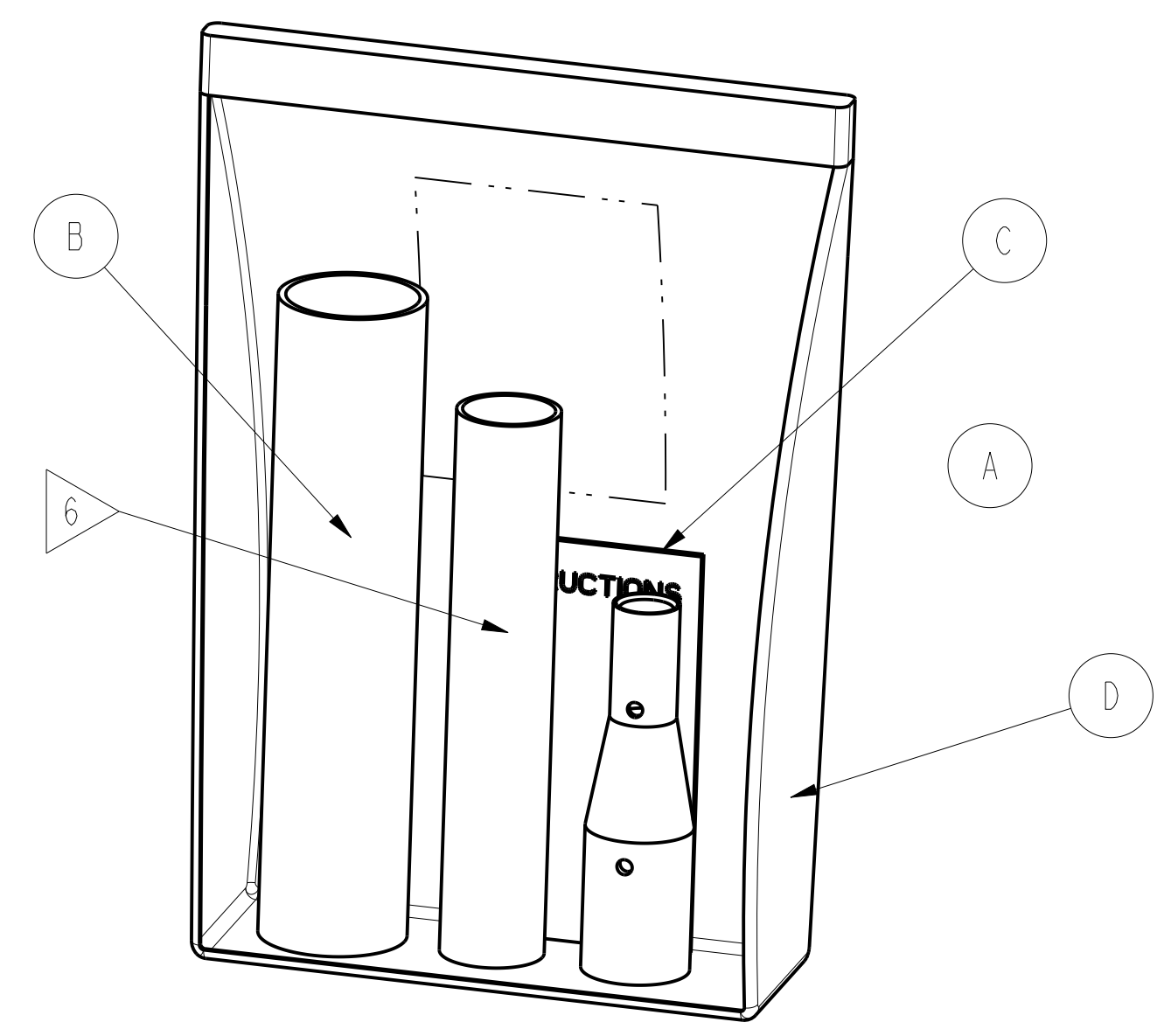

NOTES:

- ELECTRO-TIN PLATED COPPER COMPRESSION REDUCER/SPLICE; WITH A THROUGH HOLE FOR CABLE INSPECTION ON EACH SIDE; COLOR CODE, WIRE STRIP LENGTH AND CRIMP PLACEMENT INDICATIONS ARE INCLUDED. STANDARD BARRELS LISTED UL 486A.
 - HEAT SHRINK TUBING:
CLEAR - POLYVINYL CHLORIDE - LISTED UL 224, VW-1 RATING. (VERTICAL WIRE FLAME TEST)
- PASSES TELCORDIA GR-347-CORE "ABRASION TEST".
 - EACH KIT IS PACKED IN A SEALED PLASTIC BAG INCLUDING THE INSTALLATION INSTRUCTIONS IN ENGLISH, FRENCH AND SPANISH.
 - SEE TABLE FOR SPECIFIC KIT CATALOG NUMBER.
 - FOR SPECIFIC APPLICATION TOOLS AND DIES, SEE ABOVE TOOLING TABLE.
- 6 THESE ITEMS WILL BE PROVIDED WITH 2 HEAT SHRINK TUBINGS TO BE INSTALLED, ONE WILL OVERLAP THE OTHER. INSTALL THE SMALLER FIRST AND LARGER SECOND.
- 7 THESE ITEMS WILL BE DEVELOPED IN CONJUNCTION WITH TYCO ELECTRONICS POWER SYSTEMS AND WILL HAVE TYCO MARKINGS ON THEM.

TO ORDER BURNDY® PRODUCTS CALL		COMPRESSION COPPER REDUCER / SPLICE KIT	
UNITED STATES 1-800-346-4175 (LONDONDERRY, NH)		ITEM NO: --	SCALE: 1:1
CANADA: 1-800-361-6975 (QUEBEC) 1-800-387-6487 (ALL OTHER PROVINCES)		CAT. NO: (SEE TABLE)	BURNDY
FOR PRODUCT INFO: http://www.burndy.com		DRAWN BY: B.SURESH BABU 6/13/09	
		CHECKER: J.MICHAUD 11/24/09	PROJECT #: --
		DSN APPVL: J.MICHAUD 11/24/09	SIZE: D
		MFG APPVL: --	10101352
		GA APPVL: J.BRODEUR 11/25/09	B
		MKT APPVL: J.SYLVIA 11/23/09	SHEET 5 OF 5
		PROD FAM: CM&R COMPRESSION	
		REL LEVEL: Released	

REV: PEC200