

REV.	DATE	DESCRIPTION	ECO	BY	C'H'K.
B	04/23/2015 00:00:00 AM	UPDATED AS PER MARKUP	39224	MG	RM

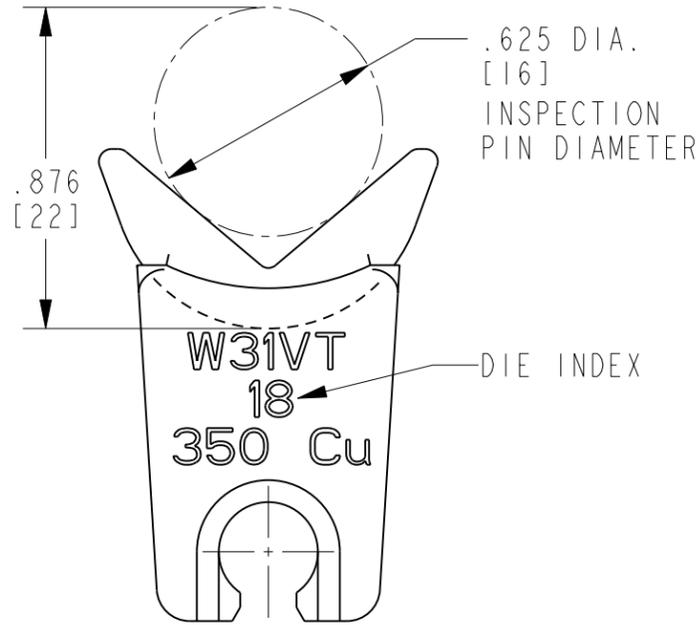
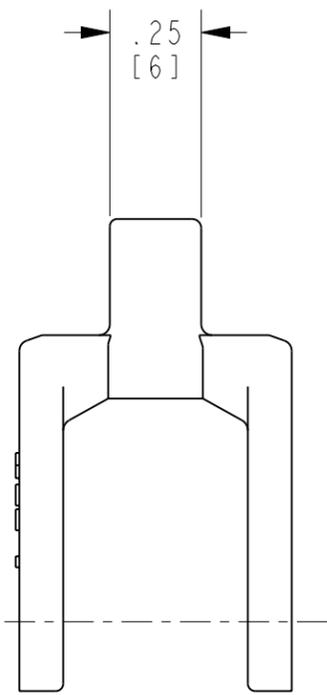
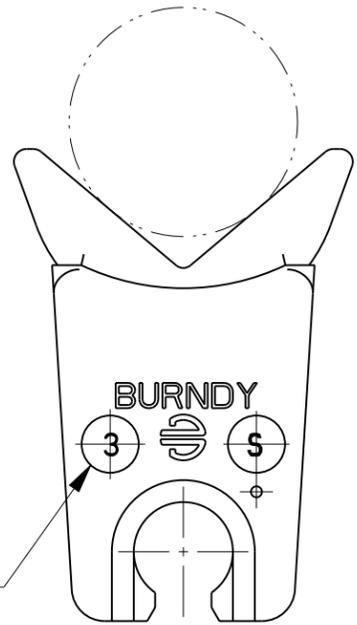
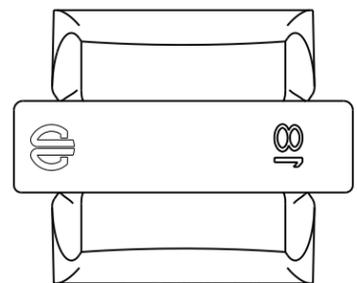

- NOTES:
- DIMENSIONS IN BRACKETS [] ARE IN MILLIMETERS ROUNDED OFF TO THE NEAREST MILLIMETER, UNLESS OTHERWISE NOTED, AND ARE FOR REFERENCE ONLY.
 - MATERIAL: STAINLESS STEEL
 - CATALOG NUMBER CONSIST OF TWO DIE HALVES.

TO ORDER BURNDY® PRODUCTS CALL		W-DIES	
UNITED STATES: 1-800-346-4175 (LONDONDERRY, NH)		ITEM NO: --	3
CANADA: 1-800-361-6975 (QUEBEC) 1-800-387-6487 (ALL OTHER PROVINCES)		CAT. NO: W31VT	
FOR PRODUCT INFO: http://www.burndy.com		DRAWN BY: M RAJASEKAR 6/12/2009	
		CHECKER: R RICK 7/13/2009	
		DSN APPVL: R RICK 7/13/2009	
		MFG APPVL: S HOPPS 8/11/2009	
		QA APPVL: A CHARLES 7/15/2009	
		MKT APPVL: P ROBERT 7/09/2009	
		PROJ FAM: TOOLS_MECHANICAL	SCALE: 2:1
		PROJECT #: --	DRAWING NO
		DOCUMENT TYPE: Sales	10102376
		REL LEVEL: Released	B
			SHEET 1 OF 1

REV: PE0200