

*** BILL OF MATERIAL ***

PT NO.	QTY	DESCRIPTION	REFERENCE
1	1	CL501TN; TINNED COPPER LAY-IN LUG	SC212515-01
2	1	#10-32 HEX. WASHER HEAD MACHINE SCREW	ANSI B18.6.4
3	1	#10 EXTERNAL TOOTH LOCK WASHER, S.S.	ANSI B18.21.1

FIELD WIRING USE#14-4 AWG CU; SOL.OR STR.	
CONDUCTOR SIZE	TIGHTENING TORQUE
14-10 AWG	20 INCH-LBS
8 AWG	25 INCH-LBS
6-4 AWG	35 INCH-LBS

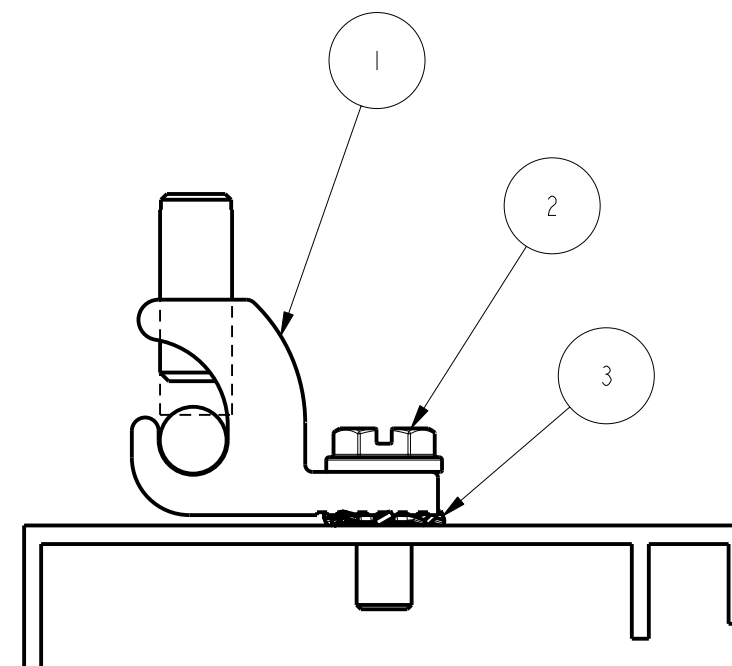

NOTES:

- REFER TO DRAWING SC212515-01 FOR DIMENSIONS OF CONNECTOR.
- MATERIAL: BODY: TIN PLATED COPPER
HARDWARE: 300 SERIES OR 18-8 STAINLESS STEEL.
- SEE ITEM NUMBER: 50061563 FOR INSTALLATION INSTRUCTIONS AND RATINGS.
- UL LISTED AND CSA CERTIFIED GROUNDING AND BONDING EQUIPMENT AND RATED FOR DIRECT BURIAL IN CONCRETE OR EARTH.
UL LISTED GROUND LUGS AND DEVICES FOR USE WITH PHOTOVOLATAIC MODUELES AND PANELS.

TO ORDER BURNDY® PRODUCTS CALL		LAY-IN LUG, TINNED COPPER W/ SS HARDWARE	
UNITED STATES:		ITEM NO: 10094191	
1-800-346-4175 (LONDONDERRY, NH)		CAT. NO: CL501TNMHWS	
CANADA:		DRAWN BY: M KATHIR 10/28/15	
1-800-361-6975 (QUEBEC)		CHECKER: R ROMAN 12/22/15	
1-800-387-6487 (ALL OTHER PROVINCES)		DSN APPVL: R ROMAN 12/22/15	
FOR PRODUCT INFO: http://www.burndy.com		MFG APPVL: -- --	
		QA APPVL: C KOWALCZYK 12/16/15	
		MKT APPVL: P THERRIEN 12/22/15	
		SCALE: 3:4	
		PROJ. FAM: MECHANICAL GROUNDING	
		DRAWING NO	
		PROJECT #: -- SIZE	
		10103051	
		DOCUMENT TYPE: Sales	
		REL LEVEL: Released	
		SHEET 1 OF 1	

REV.	DATE	DESCRIPTION	ECO	BY	C/H/K.
C	10/24/2015 00:00:00 AM	UPDATE CL501, CL501TN, AND KIT SALES DRAWINGS.	41982	MK	RR

REV: PE0200