

REV.	DATE	DESCRIPTION	ECO	BY	C'H'K.
B	4/21/2010 4:00:00 AM	RELEASE SALES DRAWING	20837	RM	JG

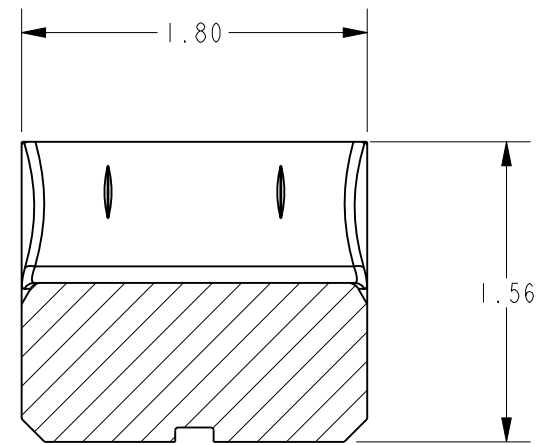
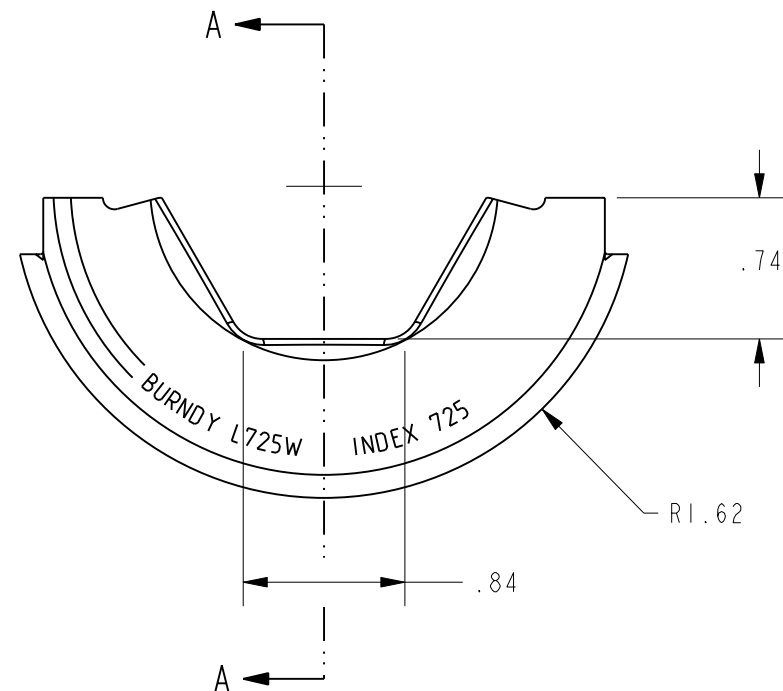
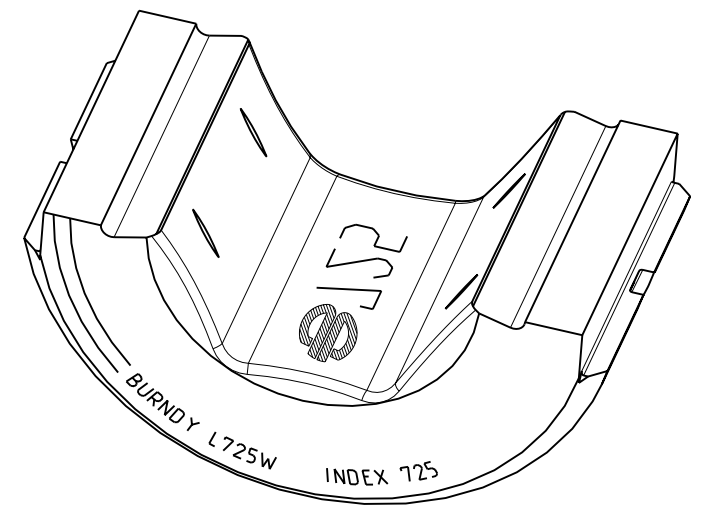
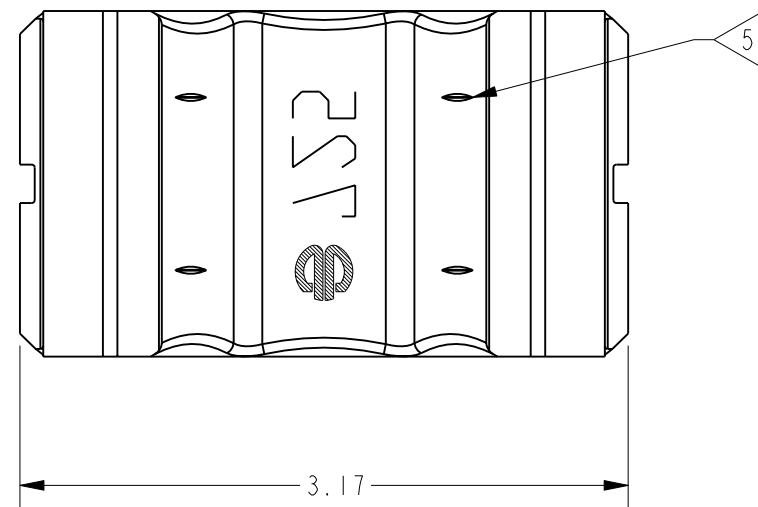

SECTION A-A

NOTES:

1. INTERPRET THIS DRAWING PER ASME Y14.5M-1994
2. USE ON Y60 HYPRESS™.
3. MATERIAL: STAINLESS STEEL
4. L725W HAS A WIDER PLOW WIDTH THAN L725 TO REDUCE THE NUMBER OF OVER-LAPPING CRIMPS.
5. USE EMBOSMENT ON CONNECTOR CREATED BY THESE INDICIA MARKS TO ALIGN OUTSIDE EDGE OF DIE. EMBOSMENT PROVIDES START LOCATION FOR THE NEXT OVERLAPPING CRIMP.

REV: PE0200

TO ORDER BURNDY® PRODUCTS CALL		L - DIE 725W															
UNITED STATES: 1-800-346-4175 (LONDONDERRY, NH)		ITEM NO: N/A															
CANADA: 1-800-361-6975 (QUEBEC) 1-800-387-6487 (ALL OTHER PROVINCES)		CAT. NO: L725W															
FOR PRODUCT INFO: http://www.burndy.com		<table border="1"> <tr> <td>DRAWN BY: R. MURUGESAN</td> <td>1/28/2010</td> <td rowspan="6" style="text-align: center; vertical-align: middle;">BURNDY</td> <td rowspan="6" style="text-align: center; vertical-align: middle;">SCALE: 1:1</td> </tr> <tr> <td>CHECKER: R. ROMAN</td> <td>4/15/2010</td> </tr> <tr> <td>DSN APPVL: R. ROMAN</td> <td>4/15/2010</td> </tr> <tr> <td>MFG APPVL: A. SHLOPAK</td> <td>4/15/2010</td> </tr> <tr> <td>QA APPVL: J. BRODEUR</td> <td>4/21/2010</td> </tr> <tr> <td>MKT APPVL: R. POIRIER</td> <td>4/16/2010</td> </tr> </table>		DRAWN BY: R. MURUGESAN	1/28/2010	BURNDY	SCALE: 1:1	CHECKER: R. ROMAN	4/15/2010	DSN APPVL: R. ROMAN	4/15/2010	MFG APPVL: A. SHLOPAK	4/15/2010	QA APPVL: J. BRODEUR	4/21/2010	MKT APPVL: R. POIRIER	4/16/2010
DRAWN BY: R. MURUGESAN	1/28/2010	BURNDY	SCALE: 1:1														
CHECKER: R. ROMAN	4/15/2010																
DSN APPVL: R. ROMAN	4/15/2010																
MFG APPVL: A. SHLOPAK	4/15/2010																
QA APPVL: J. BRODEUR	4/21/2010																
MKT APPVL: R. POIRIER	4/16/2010																
PROJECT #: --	SIZE	DRAWING NO	REV														
DOCUMENT TYPE: Sales	B	10112343	B														
REL LEVEL: Released		SHEET 1 OF 1															