

DRAWING NO.  
10113639

7

6

5

4

3

2

1

CONDUCTOR ACSS	ITEM NUMBER	CATALOG NUMBER	FIG. NO.	HARDWARE KIT	C	D	(L)	O.D	T	INSTALLATION TOOLING OVERLAP CRIMPS							
										BURNDY <sup>®</sup> HYPRESS <sup>™</sup> & DIE SET		ALCOA PRESS		T & B DIE SET		ACA DIES & PRESS	
										DIE INDEX	Y60B	I50B	H2H	T&B 21940 TYPE PRESS	60 TON PRESS	100 TON PRESS	
300-336.4 Kcmil ACSS	10113627	BYNA32R15HHT	2	TMH9	3.25 [82.5]	4.50 [114.3]	16.21 [411.7]	1.19 [30.2]	.75 [19.0]	717	L717	M717	H717	96	--	--	
	10113632	BYNA32R15HT															
397.5 Kcmil ACSS	10113799	BYNA34R15HHT	2	TMH9	3.25 [82.5]	4.50 [114.3]	16.24 [417.1]	1.30 [33.0]	.75 [19.0]	719	L719	M719	H719	106	6020AH	10020AH	
	10113800	BYNA34R15HT															
477 Kcmil ACSS	10100458	BYNA36R15HHT	2	TMH9	3.25 [82.5]	4.50 [114.3]	16.51 [419.4]	1.41 [35.7]	.75 [19.0]	720	L720	M720	H720	115	--	--	
	10100125	BYNA36R15HT															
556.5 Kcmil ACSS	10113801	BYNA39R15HHT	2	TMH9	3.25 [82.5]	4.50 [114.3]	16.89 [429.0]	1.50 [38.1]	.75 [19.0]	722	L722	M722	H722	125	6024AH	10024AH	
	10113802	BYNA39R15HT															
605-666.6 Kcmil ACSS	10113803	BYNA43R15HHT	1	TMH4	3.07 [78.0]	3.95 [100.3]	14.41 [366.0]	1.61 [40.9]	.36 [9.1]	724	L724	M724	H724	140	--	--	
	10113804	BYNA43R15HT															
715.5-795 Kcmil ACSS	10101659	BYNA45R15HHT	1	TMH24	3.22 [81.8]	3.95 [100.3]	15.10 [383.5]	1.80 [45.7]	.45 [11.4]	725	L725	M725	H725	150	--	--	
	10101658	BYNA45R15HT															
900-1113 Kcmil 45-7 STR ACSS	10108765	BYNA49R15HHT	1	TMH24	3.22 [81.8]	3.95 [100.3]	15.14 [384.5]	1.97 [50.0]	.52 [13.2]	727	L727	M727	H727	161	6030AH	10030AH	
	10108764	BYNA49R15HT															
1113 54-19 STR-1351.5 Kcmil ACSS	10108756	BYNA52R15HHT	1	TMH9	3.22 [81.8]	3.95 [100.3]	16.81 [427.0]	2.25 [57.2]	.71 [18.0]	728	L728	M728	H728	189	6036AH	10036AH	
	10108755	BYNA52R15HT															
1431 Kcmil ACSS	10113805	BYNA54R15HHT	1	TMH9	3.22 [81.8]	3.95 [100.3]	18.22 [462.8]	2.25 [57.2]	.71 [18.0]	728	L728						
	10113806	BYNA54R15HT															
1510.5-1590 Kcmil ACSS	10113807	BYNA56R15HHT	1	TMH9	3.44 [87.4]	3.95 [100.3]	17.56 [466.0]	2.50 [63.5]	.86 [21.8]	729	L729	M729	H729	204	6040AH	10040AH	
	10113808	BYNA56R15HT															
1780 Kcmil ACSS	10113809	BYNA58R15HHT	1	TMH9	3.47 [88.1]	3.95 [100.3]	18.28 [464.3]	2.50 [63.5]	.80 [20.3]	735	L735	M735	H735	212,214			
	10113810	BYNA58R15HT															
2156-2167 Kcmil ACSS	10113811	BYNA59R15HHT	1	TMH9	3.57 [90.7]	3.95 [100.3]	17.95 [455.9]	2.50 [63.5]	.64 [15.3]	735	L735			214	--	--	
	10102505	BYNA59R15HT															

REV	DATE	DESCRIPTION	ECO	BY	C'H'K.
B	07/17/2013 00:00:00 AM	T&B & ACA PRESS, COLUMNS ADDED IN THE TABLE UNDER INSTALLATION DATA OVERLAP CRIMPS	32502	MM	SP

- NOTES:
- MATERIAL:  
CONNECTOR, ALUMINUM ALLOY, NO-OX-ID COATED  
ALUMINUM FILLER PUG  
HARDWARE:  
BOLTS, ALUMINUM ALLOY WAX COATED  
NUTS AND FLAT WASHERS, ALUMINUM ALLOY  
RESILIENT WASHERS, GALVANIZED STEEL
  - RECOMMENDED TORQUE:  
1/2" DIA. ALUMINUM BOLTS, 300 IN-LB. [34 NM].
  - DESIGNED FOR CORONA FREE OPERATION TO 230 KV WITH NO ACCESSORIES.
  - FLASH FORMED DURING CRIMPING SHOULD BE REMOVED BY FILLING, AND SHARP CORNERS ROUNDED OFF. THE BARREL PORTION OF THIS CONNECTOR WILL OPERATE QUIETER THAN THE CONDUCTOR AT EXTRA HIGH VOLTAGES.
  - CONNECTOR IS INDIVIDUALLY PACKAGED AND SEALED IN POLYTUBE.
  - CONNECTOR SHALL BE SHIPPED UNASSEMBLED.
  - PENETROX<sup>™</sup> PENHT IS REQUIRED FOR INSTALLATION. PENETROX<sup>™</sup> PENHT IS NOT PROVIDED WITH THE CONNECTOR AND IS PURCHASED SEPARATELY.
  - INSTALLATION TOOLING IS PURCHASED SEPARATELY.
  - LOCATION AND DATE CODE (B=LOCATION, YY=YEAR, DDD=DAY).
  - INSTALLATION INSTRUCTION FORMI0085255 (I0085256).
  - DIMENSIONS IN BRACKETS [ ] ARE IN MILLIMETERS, AND ARE FOR REFERENCE ONLY.
  - THE DIES LISTED ARE MANUFACTURED BY BURNDY<sup>®</sup> CORP. FOR USE IN ALCOA H2H&I50B PRESSES.
  - THE EQUIVALENT T&B DIE INDEXES ARE LISTED FOR YOUR CONVENIENCE.

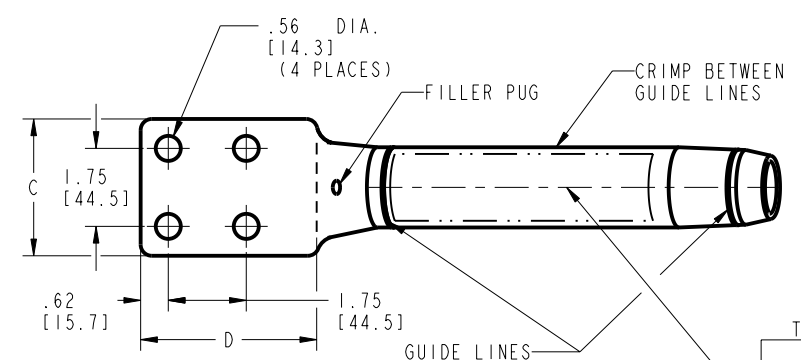

TYPICAL LETTERING  
BURNDY  
BYNA45R/RT 15 HT  
715.5-795 Kcmil ACSS  
BYDDDD  
OVERLAP CRIMPS  
USE BURNDY DIE 725  
BURNDY PRESS Y60BHU

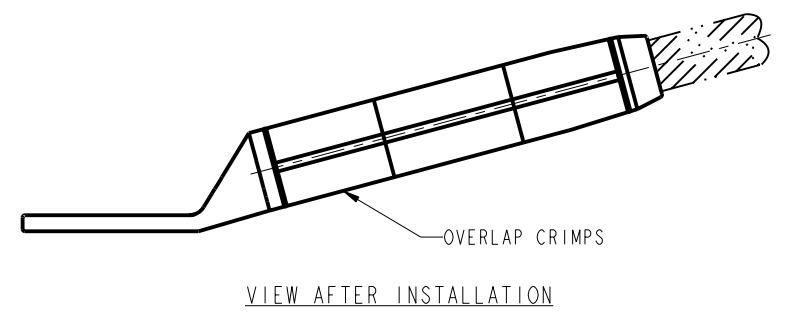
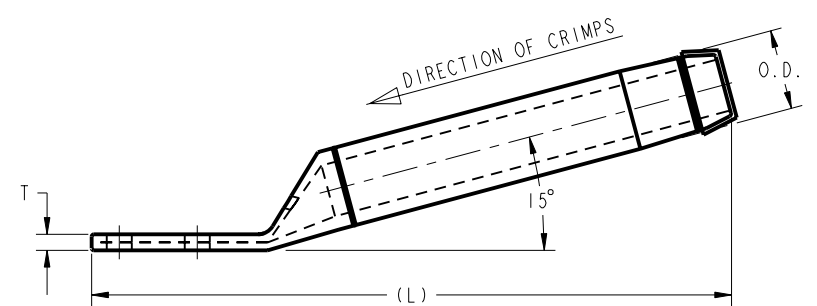
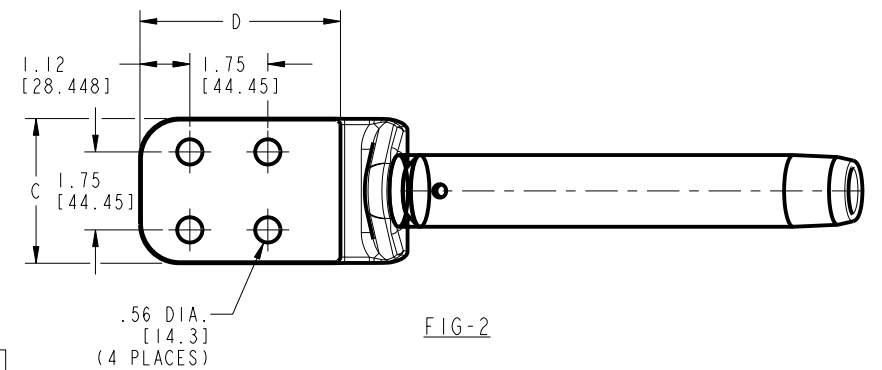

TO ORDER BURNDY <sup>®</sup> PRODUCTS CALL		15 DIG. HYLUG <sup>™</sup> & HARDWARE FOR ACSS	
UNITED STATES 1-800-346-4175 (LONDONDERRY, NH)		ITEM NO: 10113627	DRAWING NO
CANADA: 1-800-361-6975 (QUEBEC) 1-800-387-6487 (ALL OTHER PROVINCES)		CAT. NO: SEE TABLE	REV
FOR PRODUCT INFO: <a href="http://www.burndy.com">http://www.burndy.com</a>		DRAWN BY: AUGUSTIN 03/10/10	SCALE: 0.500
		CHECKER: --	
		DSN APPVL: P WALTZ 08/02/13	
		MFG APPVL: --	
		QA APPVL: C ACKERMAN 08/22/13	
		MKT APPVL: B CRUTCHER 09/04/13	
		PROJECT #: --	
		DOCUMENT TYPE: Sales	
		REL LEVEL: Released	
		SIZE: D	
		10113639	
		SHEET 1 OF 1	

REV: PEO200

8

7

6

5

4

3

2

1