

NOTES:

- 1 CREEPAGE DISTANCE: 138.9" / 3529mm
- 2 ARC DISTANCE: 45.5" / 1156mm
- 3 NOMINAL VOLTAGE: 69kV
- 4 NOMINAL CURRENT: 400A / 1200A
- 5 VOLTAGE WITHSTAND, 60 sec.: 160kV
- 6 BIL: 350kV
- 7 ROUTINE TEST ACCORDING TO: IEEE C57.19.01
- 8 MAX. TORQUE APPLIED ON FLANGE BOLTS: 40 lbf·ft / 54.2 N·m
- 9 WEIGHT: 197 lb / 89.3 kg
- 10 SILVER PLATED, AS PER ASTM B700, TYPE 1, GRADE D, CLASS N, NO NICKEL LAYER, FROM 13 TO 20 MICROMETERS THICKNESS

REVISIONS					
ZONE	REV.	DESCRIPTION	DRAWN BY	DATE	APPR.

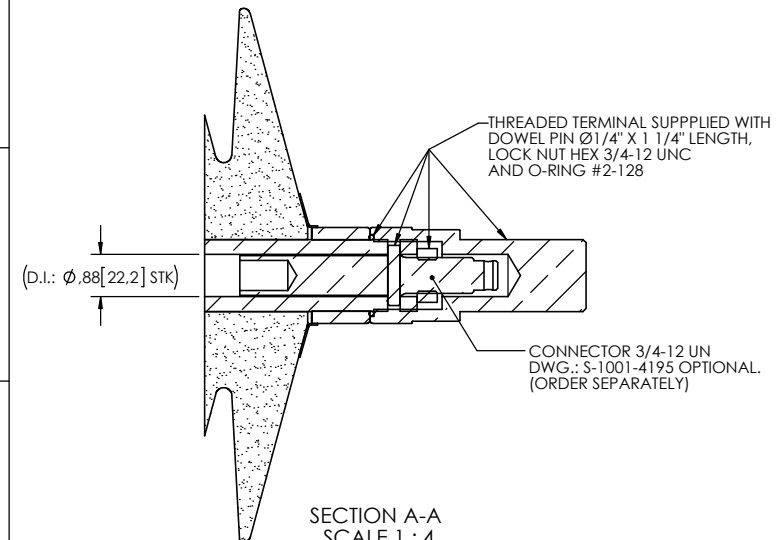
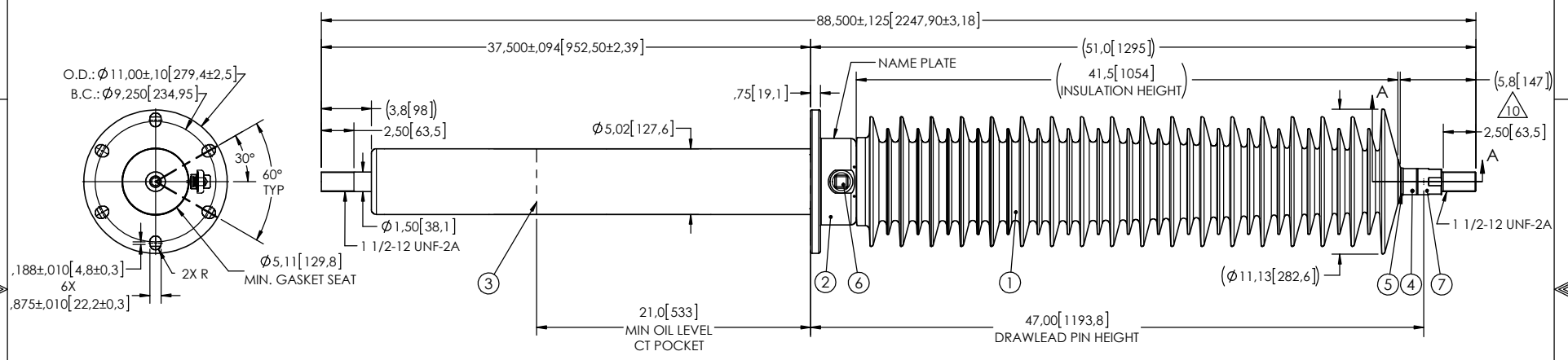

ITEM NO.	QTY	DRAWING NO.	PART NO.	DESCRIPTION	NOTE / MAT'L
7	1	S-5595-5338-1		THREADED TERMINAL KIT	COPPER
6	1	S-1001-2022		CAPACITANCE TAP ASSEMBLY	ALUMINUM
5	1	S-1344-0162-0		CAP	COPPER
4	1	S-7864-9737		TUBE ASSEMBLY	COPPER
3	1	S-3872-9712		SHIELD ASSEMBLY	COPPER
2	1	S-3872-9711		FLANGE	ALUMINUM
1	1	S-7864-9736	-001	CASTING, CYCLOALIPHATIC RESIN	EC-APG-02

PARTS LIST					
GENERAL TOLERANCES (UNLESS OTHERWISE SPECIFIED)			<p style="text-align: center;">ElectroComposites™ solid HV bushings solution</p> <p style="text-align: center;">TITLE: SDC® BUSHING 69kV, 400/1200A MODEL: 350-412-T-1030-00</p>		
X.	±0.125				
.X	±0.094				
.XX	±0.063				
.XXX	±0.031				
ANGLES	±0.25°				
RADIUS	±0.031				
REMOVE BURRS AND BREAK SHARP EDGES			DRAWN BY: A.SAVARD DATE: 2018/07/04		
DIMENSIONS ARE IN INCHES (UNLESS OTHERWISE SPECIFIED)			PROJECTING: []		
			PROJECT MANAGER: []		
SCALE: 1:12		GENERATED BY: SolidWorks 2013		SHEET: 1 of 1	

This drawing is the proprietary property of Electro Composites (2008) ULC, not part of the public domain, and is issued with the express understanding and agreement that it is not to be reproduced or copied in whole or in part or issued for furnishing information to others, or used directly or indirectly, in any way detrimental to the interest of Electro Composites (2008) ULC and is to be returned upon request by Electro Composites (2008) ULC. All Rights Reserved.