

NOTES:

- 1 CREEPAGE DISTANCE: 48.1" / 1222mm
- 2 ARC DISTANCE: 18.5" / 470mm
- 3 NOMINAL VOLTAGE: 34.5kV
- 4 NOMINAL CURRENT: 6000A
- 5 VOLTAGE WITHSTAND, 60 sec.: 80kV
- 6 BIL : 200kV
- 7 ROUTINE TEST ACCORDING TO: IEEE C57.19.01
- 8 MAX. TORQUE APPLIED ON FLANGE BOLTS: 70 lbf·ft / 94.9 N·m
- 9 WEIGHT: 307 lb / 139.3 Kg
- 10 SILVER PLATED, AS PER ASTM B700, TYPE 1, GRADE D, CLASS N, NO NICKEL LAYER, FROM 13 TO 20 MICROMETERS THICKNESS
- 11 BUSHING NOT SUITABLE FOR ENCLOSED APPLICATION.
- 12 INSULATION THERMAL LIMIT: 130°C. BUSHING RATED PER IEEE C57.19.00 USUAL SERVICE CONDITIONS.

REVISIONS					
ZONE	REV.	DESCRIPTION	DRAWN BY	DATE	APPR.
E4	A	UPDATE NOTE #12	M. FORGET	2023-01-09	Y.V.

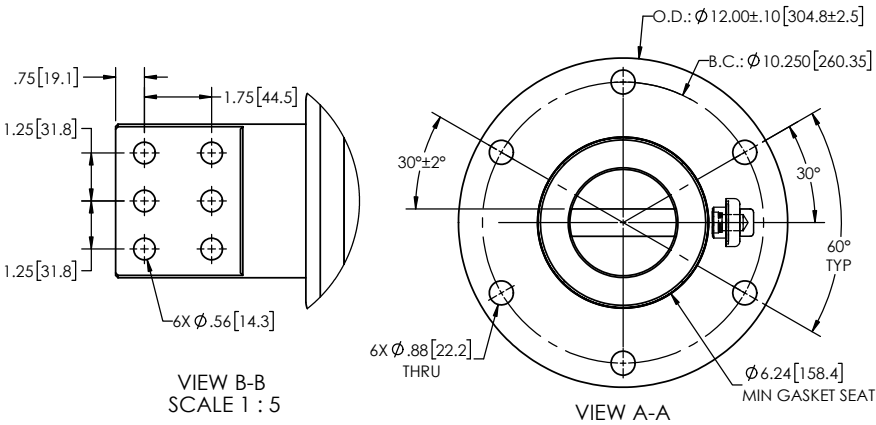
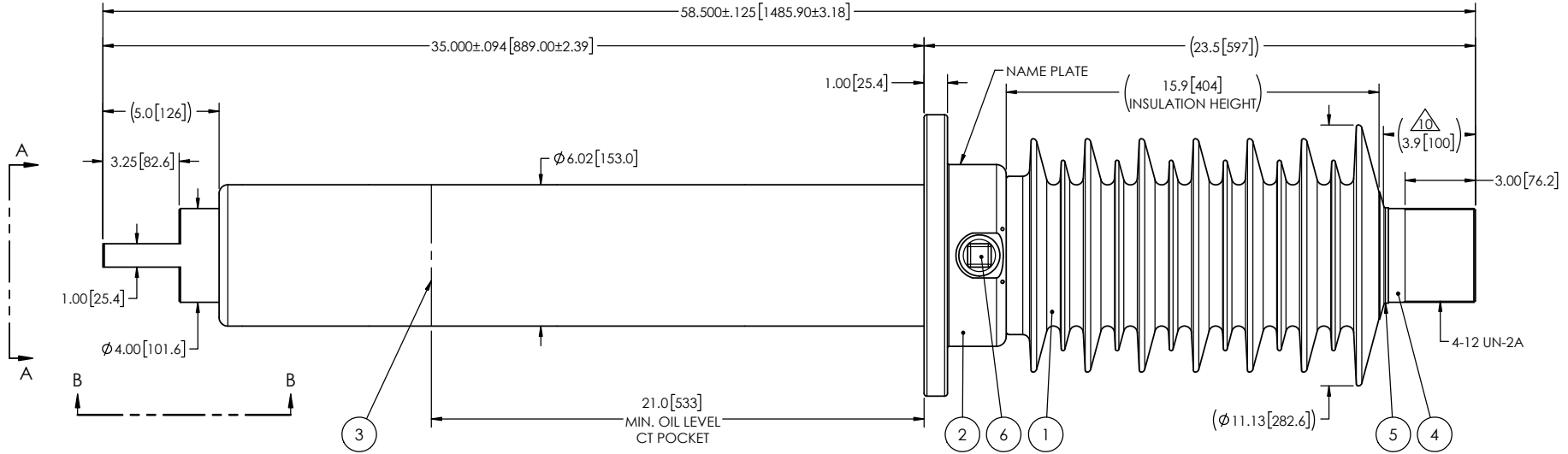

ITEM NO.	QTY	DRAWING NO.	PART NO.	DESCRIPTION	NOTE / MAT'L
6	1	S-1001-2022		CAPACITANCE TAP ASSEMBLY	ALUMINUM
5	1	S-3974-3543		CAP	COPPER
4	1	S-9046-8428		ROD ASSEMBLY	COPPER
3	1	S-9046-8427		SHIELD ASSEMBLY	COPPER
2	1	S-6187-5769		FLANGE	ALUMINUM
1	1	S-8414-9877	-001	CASTING, CYCLOALIPHATIC RESIN	EC-APG-15NA

PARTS LIST

GENERAL TOLERANCES (UNLESS OTHERWISE SPECIFIED)

- X. ±0.125
- .X ±0.094
- .XX ±0.063
- .XXX ±0.031
- ANGLES ±0.25°
- RADIUS ±0.031

REMOVE BURRS AND BREAK SHARP EDGES

DIMENSIONS ARE IN INCHES (UNLESS OTHERWISE SPECIFIED)

Electro Composites
solid HV bushings solution

TITLE: SDC® BUSHING 34.5kV, 6000A
MODEL: 200-060-T-1040-00

DRAWN BY: M. FORGET DATE: 2019/01/03

CHECK BY:

PROJECT ENG.:

PROJECT MANAGER:

FORMAT: A CAGE CODE: DRAWING NO.: S-8414-9877 REVISION: A

SCALE: 1:7 GENERATED BY: SolidWorks 2022 SHEET: 1 of 1

This drawing is the proprietary property of Electro Composites (2008) ULC, not part of the public domain, and is issued with the express understanding and agreement that it is not to be reproduced or copied in whole or in part or issued for furnishing information to others, or used directly or indirectly, in any way detrimental to the interest of Electro Composites (2008) ULC and is to be returned upon request by Electro Composites (2008) ULC. All Rights Reserved.