

NOTES:

- 1 CREEPAGE DISTANCE: IN: 22.8" / 580mm OUT: 48.6" / 1234mm
- 2 ARC DISTANCE: IN: 16.7" / 424mm OUT: 18.8" / 479mm
- 3 NOMINAL VOLTAGE: 34.5kV
- 4 NOMINAL CURRENT: 3300A
- 5 VOLTAGE WITHSTAND, 60 sec.: 80kV
- 6 BIL: 200kV
- 7 ROUTINE TEST ACCORDING TO: IEEE C57.19.01
- 8 MAX. TORQUE APPLIED ON FLANGE BOLTS: 70 lbf · ft / 94.9 N · m
- 9 WEIGHT: 130 lb / 59 kg
- 10 SILVER PLATED, AS PER ASTM B700, TYPE 1, GRADE D, CLASS N, NO NICKEL LAYER, FROM 13 TO 20 MICROMETERS THICKNESS

REVISIONS					
ZONE	REV.	DESCRIPTION	DRAWN BY	DATE	APPR.
B4	A	SHIELD ASSEMBLY S-8030-7459 CHANGED FOR S-8596-10407	M. FORGET	2022-04-20	Y.V.

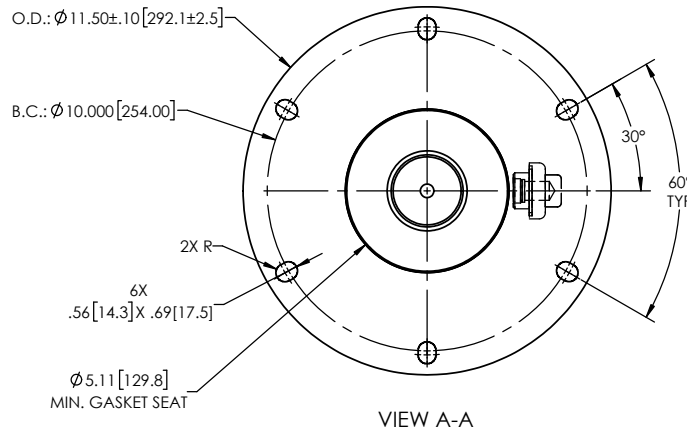
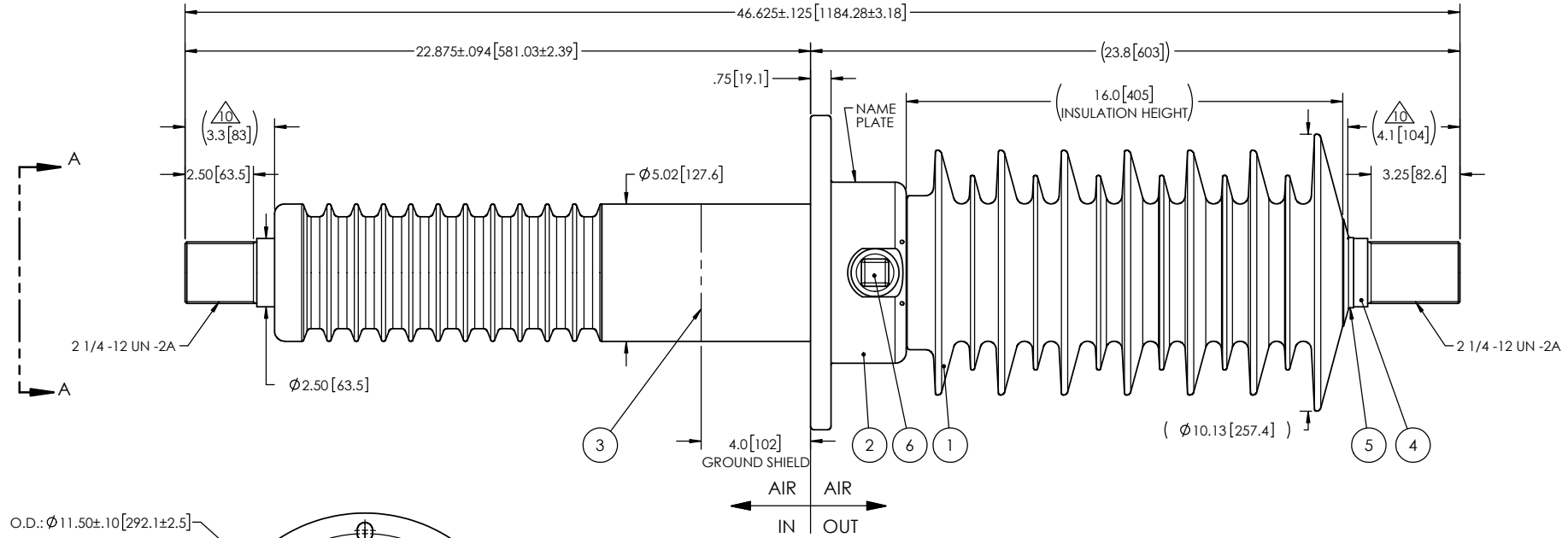

This drawing is the proprietary property of Electro Composites (2008) ULC, not part of the public domain, and is issued with the express understanding and agreement that it is not to be reproduced or copied in whole or in part or issued for furnishing information to others, or used directly or indirectly, in any way detrimental to the interest of Electro Composites (2008) ULC and is to be returned upon request by Electro Composites (2008) ULC. All Rights Reserved.

ITEM NO.	QTY	DRAWING NO.	PART NO.	DESCRIPTION	NOTE / MAT'L
6	1	S-1001-2022		CAPACITANCE TAP ASSEMBLY	ALUMINUM
5	1	S-3692-2417-0		CAP	COPPER
4	1	S-8596-10236		ROD ASSEMBLY	COPPER
3	1	S-8596-10407		SHIELD ASSEMBLY	COPPER
2	1	S-9920-9991		FLANGE	ALUMINUM
1	1	S-8596-10234	-001	CASTING, CYCLOALIPHATIC RESIN	EC-APG-02

PARTS LIST					
GENERAL TOLERANCES (UNLESS OTHERWISE SPECIFIED)			<p>Electro Composites solid HV bushings solution</p> <p>TITLE: SDC® BUSHING 34.5kV, 3300A MODEL: 200-033-W-1072-00</p>		
X.	±0.125				
.X	±0.094				
.XX	±0.063				
.XXX	±0.031				
ANGLES	±0.25°				
RADIUS	±0.031				
REMOVE BURRS AND BREAK SHARP EDGES			DRAWN BY: M. FORGET DATE: 2021/01/21		
DIMENSIONS ARE IN INCHES (UNLESS OTHERWISE SPECIFIED)			CHECK BY:		
			PROJECT ENG.:		
			PROJECT MANAGER:		
SCALE: 1:6		GENERATED BY: SolidWorks 2021		SHEET: 1 of 1	