

NOTES:

- 1 CREEPAGE DISTANCE: 25.3" / 642mm
  - 2 ARC DISTANCE: 11.3" / 286mm
  - 3 NOMINAL VOLTAGE: 25kV
  - 4 NOMINAL CURRENT: 6000A
  - 5 VOLTAGE WITHSTAND, 60 sec.: 60kV
  - 6 BIL: 150kV
  - 7 ROUTINE TEST ACCORDING TO: IEEE C57.19.01
  - 8 MAX. TORQUE APPLIED ON FLANGE BOLTS: 70 lbf·ft / 94.9 N·m
  - 9 WEIGHT: 328 lb / 148.8 kg
  - 10 MAXIMUM OPERATING TEMPERATURE: 130°C
- ⚠ SILVER PLATED, AS PER ASTM B700, TYPE 1, GRADE D, CLASS N.  
NO NICKEL LAYER, FROM 13 TO 20 MICROMETERS THICKNESS

REVISIONS					
ZONE	REV.	DESCRIPTION	DRAWN BY	DATE	APPR.

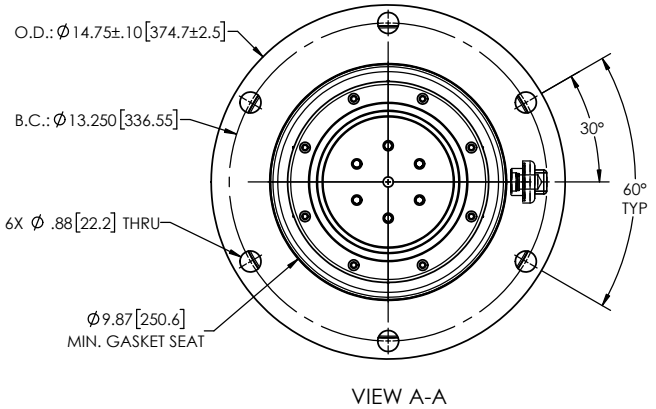
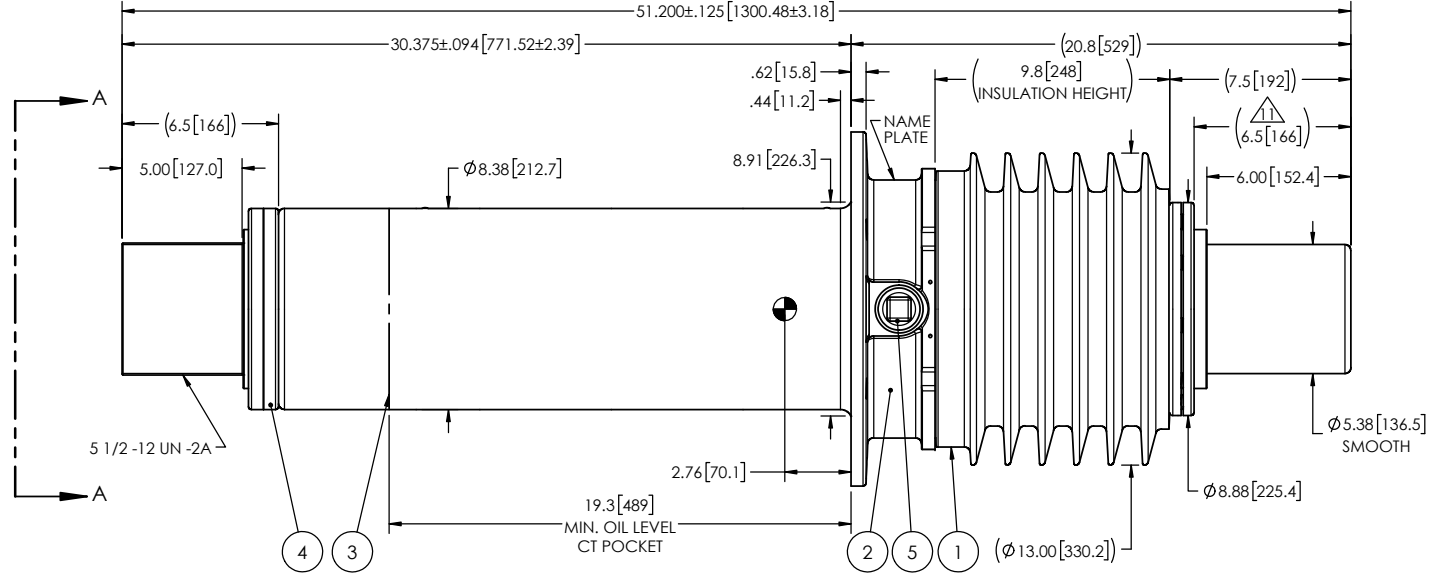

ITEM NO.	QTY	DRAWING NO.	PART NO.	DESCRIPTION	NOTE / MAT'L
5	1	S-1001-2022		CAPACITANCE TAP ASSEMBLY	ALUMINUM
4	1	S-8508-10348		TUBE ASSEMBLY	COPPER
3	1	S-8508-10354		SHIELD ASSEMBLY	BRASS
2	1	S-5955-5577		FLANGE	ALUMINUM
1	1	S-8508-10347	-001	CASTING, CYCLOALIPHATIC RESIN	EC-APG-15NA

PARTS LIST					
GENERAL TOLERANCES (UNLESS OTHERWISE SPECIFIED) X. ±0.125 .X ±0.094 .XX ±0.063 .XXX ±0.031 ANGLES ±0.25° RADIUS ±0.031			<b>Electro Composites</b> solid HV bushings solution TITLE: SDC® GSU BUSHING 25kV, 6000A MODEL: 150-060-G-1093-00		
REMOVE BURRS AND BREAK SHARP EDGES DIMENSIONS ARE IN INCHES (UNLESS OTHERWISE SPECIFIED)					
DRAWN BY: M. FORGET CHECK BY: PROJECT ENG.: PROJECT MANAGER:	DATE: 2021/10/04	FORMAT: A SCALE: 1:8	CAGE CODE: DRAWING NO.: S-8508-10347 GENERATED BY: SolidWorks 2021	REVISION: NR SHEET: 1 of 1	

This drawing is the proprietary property of Electro Composites (2008) ULC, not part of the public domain, and is issued with the express understanding and agreement that it is not to be reproduced or copied in whole or in part or issued for furnishing information to others, or used directly or indirectly, in any way detrimental to the interest of Electro Composites (2008) ULC and is to be returned upon request by Electro Composites (2008) ULC. All Rights Reserved.