

- NOTES:
- 1 CREEPAGE DISTANCE: 34.2" / 869mm
 - 2 ARC DISTANCE: 13.9" / 353mm
 - 3 NOMINAL VOLTAGE: 25KV
 - 4 NOMINAL CURRENT: 4000A
 - 5 VOLTAGE WITHSTAND, 60 sec.: 60kV
 - 6 BIL : 150kV
 - 7 ROUTINE TEST ACCORDING TO: IEEE C57.19.01
 - 8 MAX. TORQUE APPLIED ON FLANGE BOLTS: 70 lbf·ft / 94.9 N·m
 - 9 WEIGHT: 167 lb / 75.8 Kg
- △ SILVER PLATED, AS PER ASTM B700, TYPE 1, GRADE D, CLASS N, NO NICKEL LAYER, FROM 13 TO 20 μm THICKNESS

REVISIONS					
ZONE	REV.	DESCRIPTION	DRAWN BY	DATE	APPR.

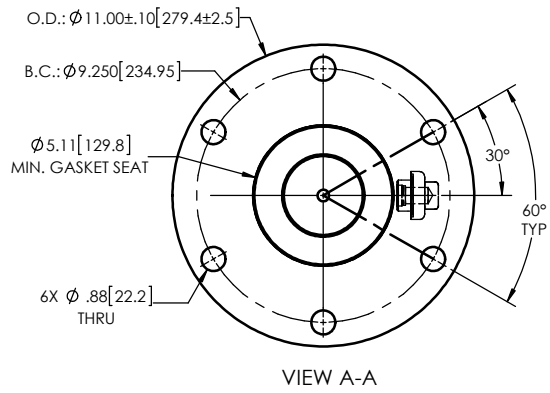
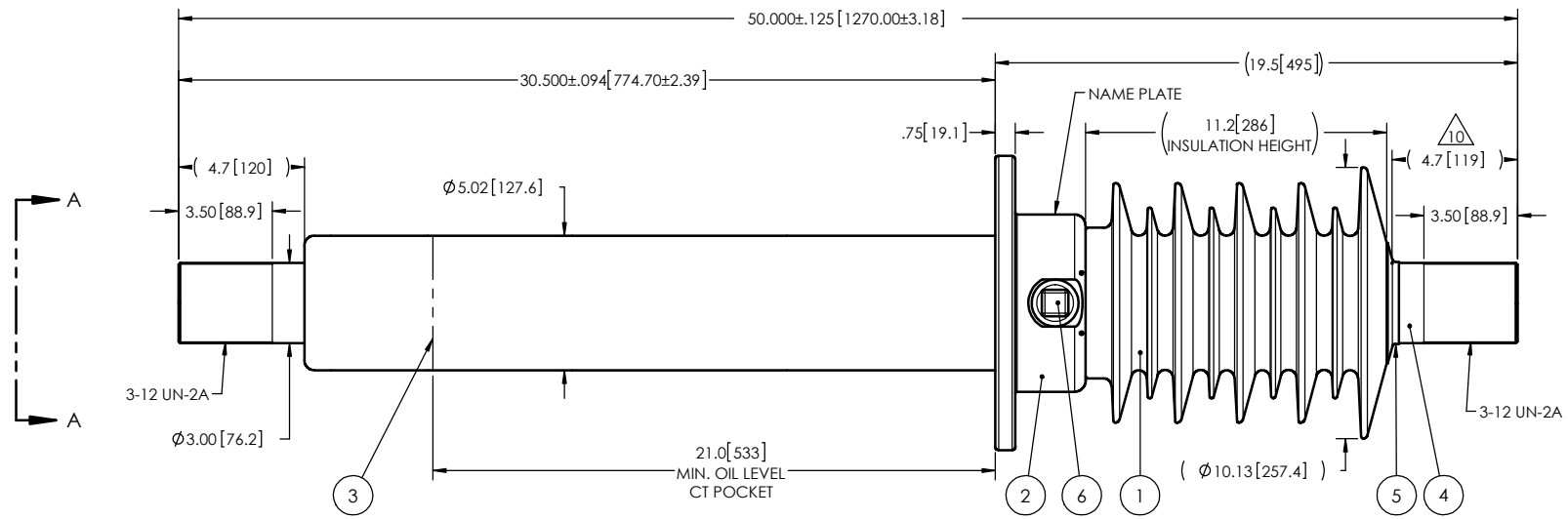

ITEM NO.	QTY	DRAWING NO.	PART NO.	DESCRIPTION	NOTE / MAT'L
6	1	S-1001-2022		CAPACITANCE TAP ASSEMBLY	ALUMINUM
5	1	S-3529-2532		CAP	COPPER
4	1	S-8153-8996		ROD ASSEMBLY	COPPER
3	1	S-5670-5342		SHIELD ASSEMBLY	COPPER
2	1	S-6074-5704		FLANGE	ALUMINUM
1	1	S-8153-8995	-001	CASTING, CYCLOALIPHATIC RESIN	EC-APG-02

PARTS LIST					
GENERAL TOLERANCES (UNLESS OTHERWISE SPECIFIED)			<p style="text-align: center;">Electro Composites™ solid HV bushings solution</p> <p>TITLE: SDC® BUSHING 25kV, 4000A MODEL: 150-040-210-00</p>		
X.	±0.125				
.X	±0.094				
.XX	±0.063				
.XXX	±0.031				
ANGLES	±0.25°				
RADIUS	±0.031				
REMOVE BURRS AND BREAK SHARP EDGES			DRAWN BY: J. CLICHE DATE: 2015/11/26		
DIMENSIONS ARE IN INCHES (UNLESS OTHERWISE SPECIFIED)			CHECK BY:		
			PROJECTING:		
			PROJECT MANAGER:		
SCALE: 1:5		GENERATED BY: SolidWorks 2013		SHEET: 1 of 1	

This drawing is the proprietary property of Electro Composites (2008) ULC, not part of the public domain, and is issued with the express understanding and agreement that it is not to be reproduced or copied in whole or in part or issued for furnishing information to others, or used directly or indirectly, in any way detrimental to the interest of Electro Composites (2008) ULC and is to be returned upon request by Electro Composites (2008) ULC. All Rights Reserved.