

15 kV COLD SHRINK TERMINATION KIT

Conforms to all Requirements of IEEE Std. 48 and C119.4
Latest Revision

Ratings

Maximum Continuous Voltage.....8.7 kV Phase-to-Ground

Insulation Withstand Voltages

Basic Impulse Level.....110 kV Crest (1.2 x 50 μ Sec. wave)
60 Hz (60 Sec.) Dry.....50 kV rms
60 Hz (6 Hr.) Dry.....35 kV rms
60 Hz (10 Sec.) Wet.....45 kV rms
Partial Discharge Extinction Voltage (5 pC).....13 kV rms

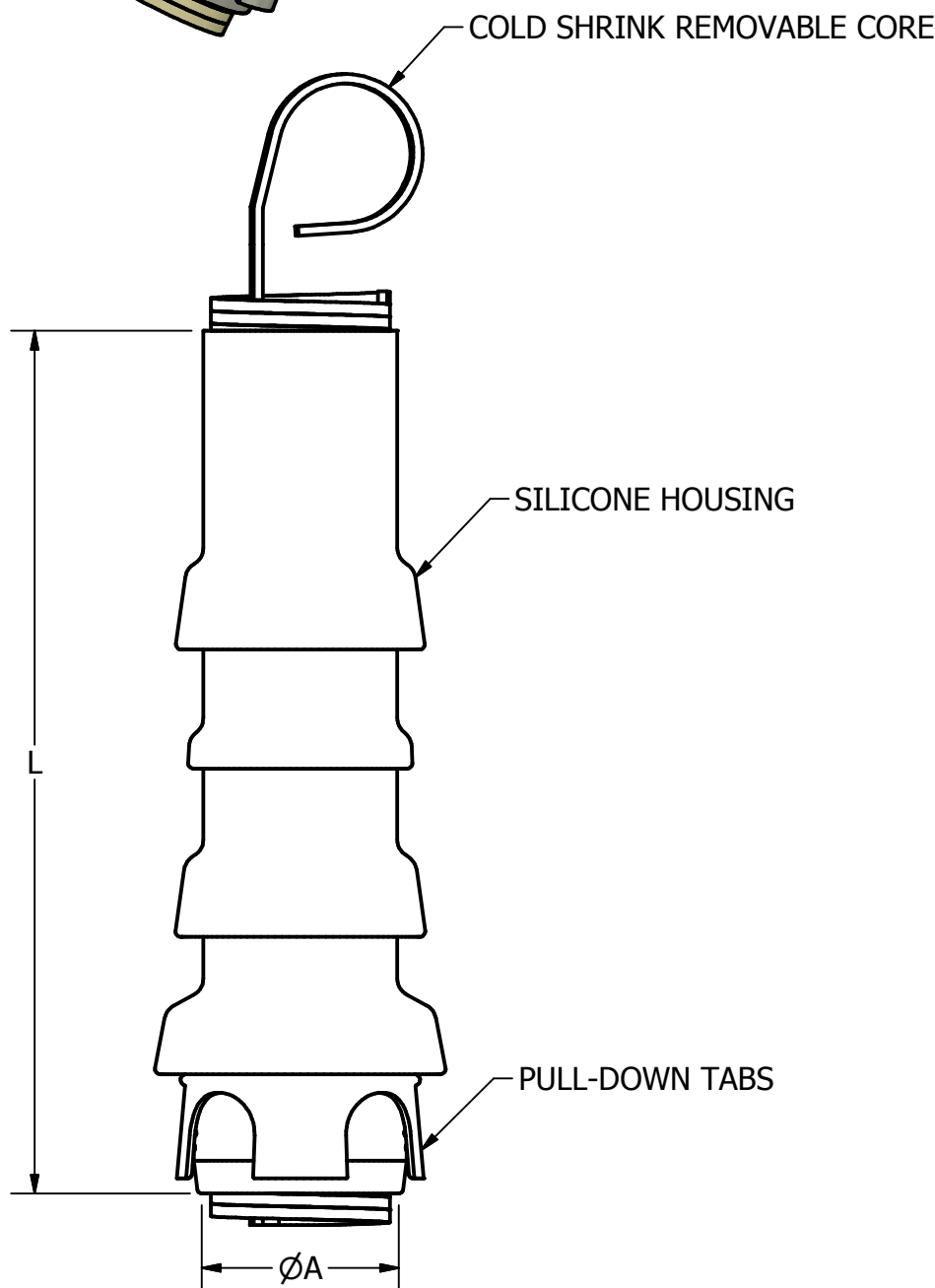
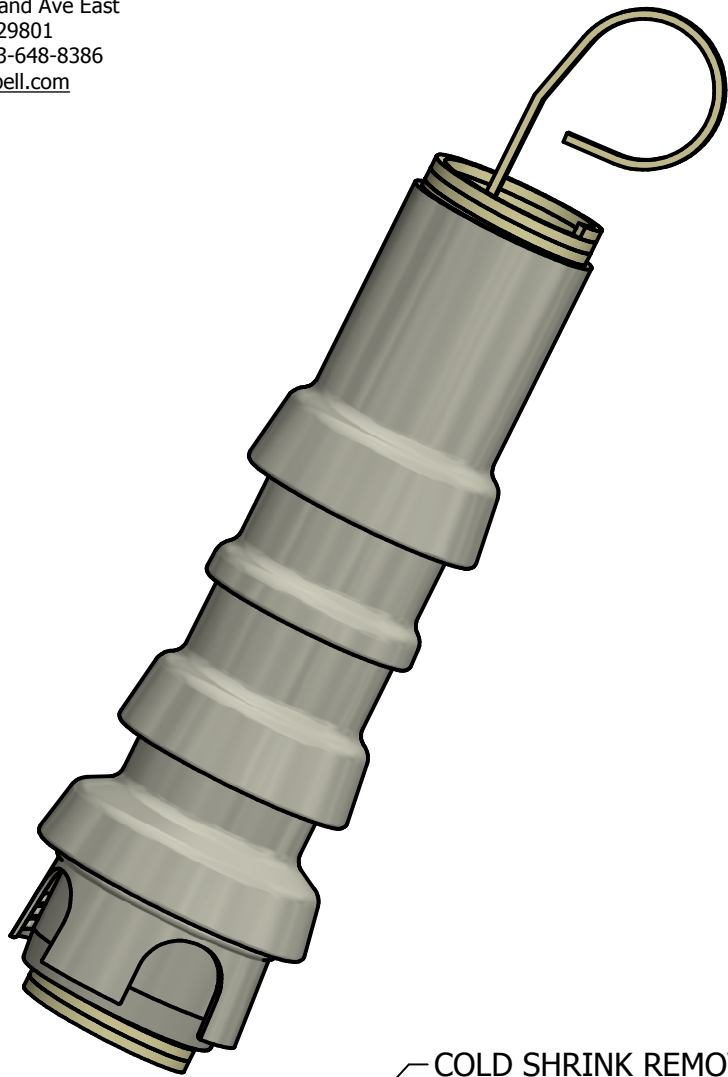

TABLE 1

HOUSING CODE	INSULATION DIA. (in.)	L (in.)	ØA (in.)
1	0.57 - 0.98	8.66	1.38
3	0.85 - 1.50	9.45	1.89
5	1.08 - 1.97	10.23	2.36

TABLE 2

CONNECTOR CODE	CONDUCTOR SIZE	STRANDING
A22	#2	Stranded & Compressed
	#1	Compact & Solid
	#1	Stranded & Compressed
	1/0	Compact & Solid
A24	1/0	Stranded & Compressed
	2/0	Compact & Solid
A25	2/0	Stranded & Compressed
	3/0	Compact & Solid
A26	3/0	Stranded & Compressed
	4/0	Compact & Solid
A27/B27	4/0	Stranded & Compressed
	250	Compact
B30	250	Stranded & Compressed
	350	Stranded & Compressed
B33	500	Compact
	600	Stranded & Compressed
B38	750	Compact
	700	Stranded & Compressed
B41	750	Stranded & Compressed
	1000	Stranded & Compressed

ORDERING INFORMATION:

15TW**X1X2X3**

X1 = HOUSING CODE (SEE TABLE 1)

X2 = CONNECTOR (SEE TABLE 2)

X3 = G FOR GROUND KIT
BLANK FOR NONE

FOR TERMINATIONS WITHOUT CONNECTOR USE:

15TW10 = HOUSING CODE 1

15TW30 = HOUSING CODE 3

15TW50 = HOUSING CODE 5

The Hubbell Cold Shrink Termination manufactured with silicone rubber, is designed for 15 kV applications and offers easy installation and reliable performance when terminating outdoor medium voltage solid dielectric cables. Hubbell Cold Shrink Terminations are designed for use on 3 & 4-wire systems, or single phase taps from these systems. Removal of the inner support core allows the termination to shrink evenly on the cable, producing a tight void free interface between the cable and termination housing.

<p>CONTENTS ARE CONFIDENTIAL AND THE EXCLUSIVE PROPERTY OF HUBBELL POWER SYSTEMS. NO PUBLICATION, DISTRIBUTION OR COPIES MAY BE MADE WITHOUT THE WRITTEN CONSENT OF HUBBELL POWER SYSTEMS. HUBBELL POWER SYSTEMS UNPUBLISHED ALL RIGHTS RESERVED UNDER THE COPYRIGHT LAWS.</p>		HUBBELL POWER SYSTEMS, Inc.		
		<p>TITLE 15 kV COLD SHRINK TERMINATION</p>		
REV DATE	SIZE	DWG NO.	CAT / PART / ASSY NO.	REV
3/8/2018	SB	---	15TW	2
DO NOT SCALE THIS DRAWING		DRN BY BVB	DATE 10/3/2017	SHEET 1 OF 1