

- NOTES:
- 1 CREEPAGE DISTANCE: 52.2" / 1327mm Ⓟ
  - 2 ARC DISTANCE: 22.8" / 581mm Ⓟ
  - 3 NOMINAL VOLTAGE: 34.5kV
  - 4 NOMINAL CURRENT: 1200A
  - 5 VOLTAGE WITHSTAND, 60 sec.: 80kV
  - 6 BIL: 200kV
  - 7 ROUTINE TEST ACCORDING TO: IEEE C57.19.01
  - 8 MAX. TORQUE APPLIED ON FLANGE BOLTS: 40 lbf-ft / 54.2 N m
  - 9 WEIGHT: 87 lb / 39.5 kg

REVISIONS					
ZONE	REV.	DESCRIPTION	DRAWN BY	DATE	APPR.
	A	CASTING UNDER FLANGE REDUCE TO Ø3.29" AND FLANGE IS NOW SQUARE	I. LÉVEILLÉ	2006-06-21	J.V.
- A1 A2 A3 C3, F5	B	GENERAL UPDATE PER ACTUAL STANDARD MODEL CHANGE FROM E1 68H TO 200-012-B-168-00 ADD THE "SDC" DESIGNATION TO THE BUSHING NAME. DIMENSION UNIT CHANGED FROM MILLIMETER TO INCHES ADD SHEDS, INCREASE CREEPAGE AND ARC DISTANCE ACCORDINGLY	M. FORGET	2022-02-21	Y.V.

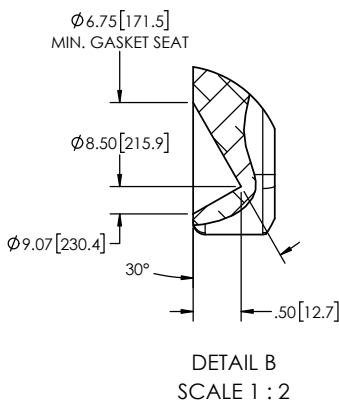
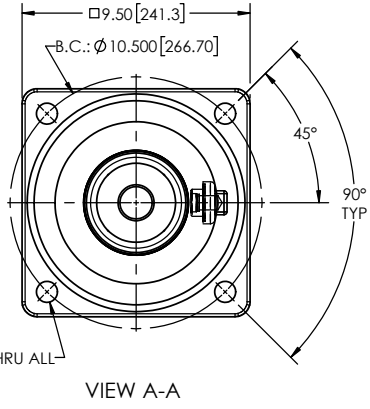
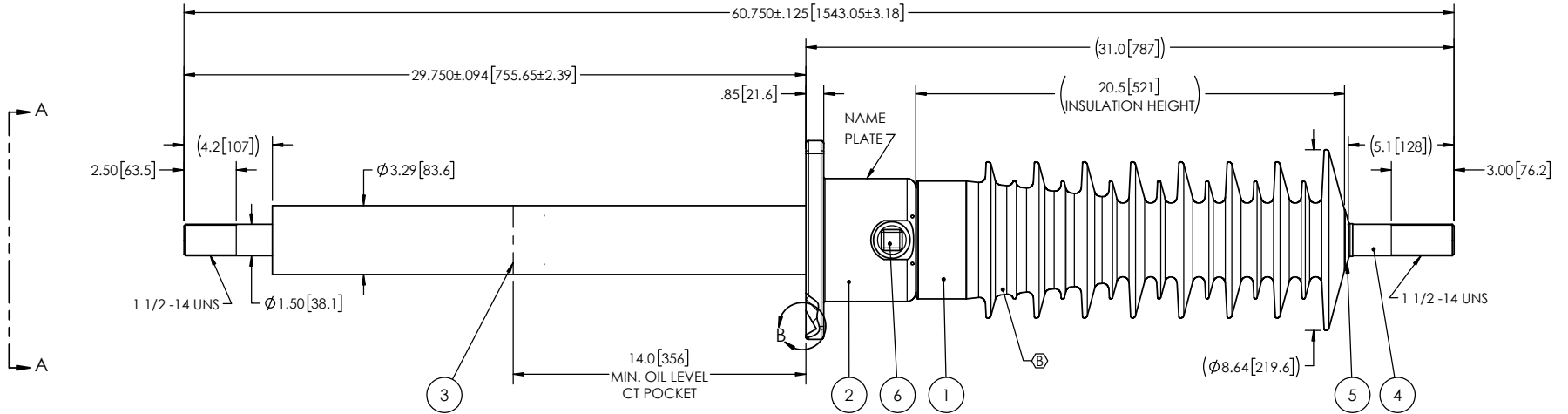

ITEM NO.	QTY	DRAWING NO.	PART NO.	DESCRIPTION	NOTE / MAT'L
6	1	S-1001-2022		CAPACITANCE TAP ASSEMBLY	ALUMINUM
5	1	S-1001-0007		CAP	COPPER
4	1	S-4129-2851		ROD ASSEMBLY	COPPER
3	1	S-4129-2852		SHIELD ASSEMBLY	COPPER
2	1	S-4129-2853		FLANGE	ALUMINUM
1	1	S-4129-2824	-001	CASTING, CYCLOALIPHATIC RESIN	EC-APG-02

**ElectroComposites™**  
**solid HV bushings solution**

TITLE: Ⓟ SDC® BUSHING 34.5kV, 1200A  
MODEL: 200-012-B-168-00 Ⓟ

DRAWN BY: I. LÉVEILLÉ	DATE: 2004-12-20	FORMAT: A	CAGE CODE	DRAWING NO.: S-4129-2824	REVISION: B
CHECK BY:		PROJECT NO.:		SCALE: 1:8	GENERATED BY: SolidWorks 2021
PROJECT MGR.:				SHEET: 1 of 1	

GENERAL TOLERANCES (UNLESS OTHERWISE SPECIFIED)  
 X. ±0.125  
 .X ±0.094  
 .XX ±0.063  
 .XXX ±0.031  
 ANGLES ±0.25°  
 RADIUS ±0.031

REMOVE BURRS AND BREAK SHARP EDGES  
 DIMENSIONS ARE IN Ⓟ INCHES (UNLESS OTHERWISE SPECIFIED)

This drawing is the proprietary property of Electro Composites (2008) ULC, not part of the public domain, and is issued with the express understanding and agreement that it is not to be reproduced or copied in whole or in part or issued for furnishing information to others, or used directly or indirectly, in any way detrimental to the interest of Electro Composites (2008) ULC and is to be returned upon request by Electro Composites (2008) ULC. All Rights Reserved.