

ITEM NO.	Description	Material	Finish	QTY.
1	2" TRADE SIZE RIGID COMPRESSION CONNECTOR BODY	C1008 COLD ROLLED STEEL	.0005 ZINC MIN.	1
2	2" TRADE SIZE GLAND RING	C1008 GALVANIZED STEEL	.0005 ZINC MIN.	2
3	2.625-14 UNS 2B COMPRESSION NUT	C1008 COLD ROLLED STEEL	.0005 ZINC MIN.	2

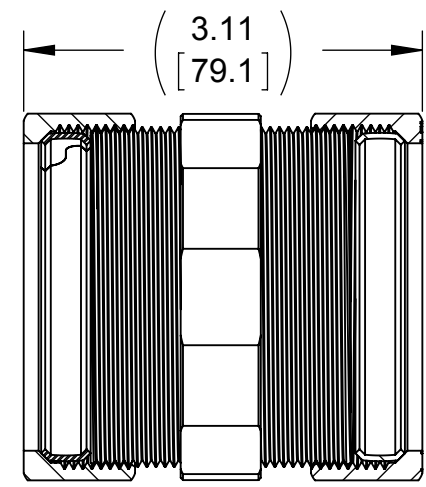

SECTION A-A

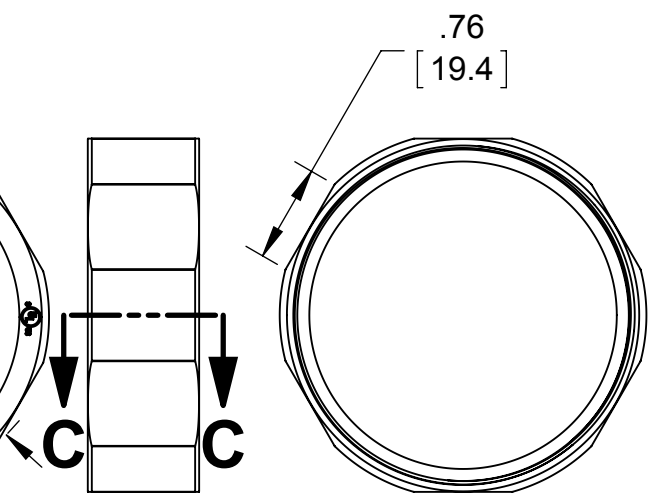
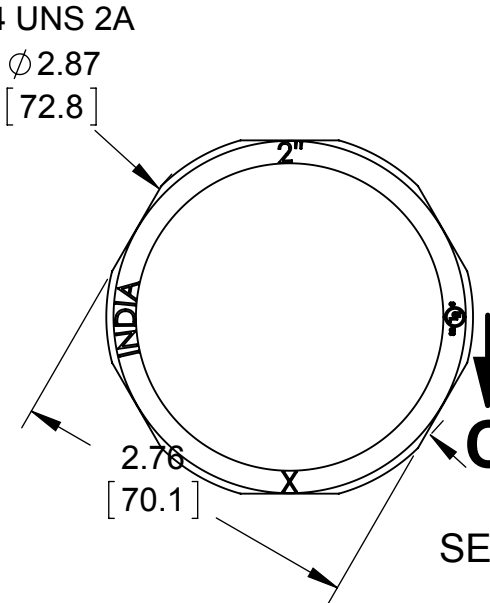
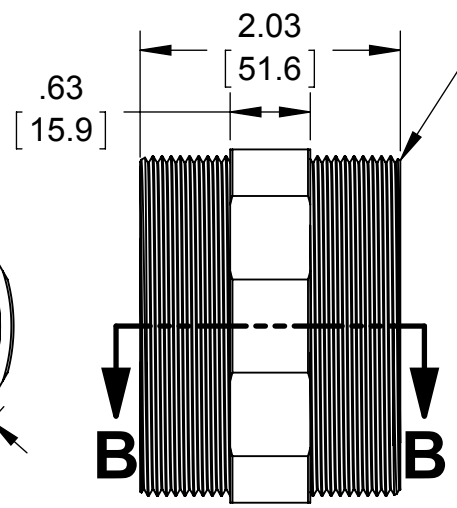
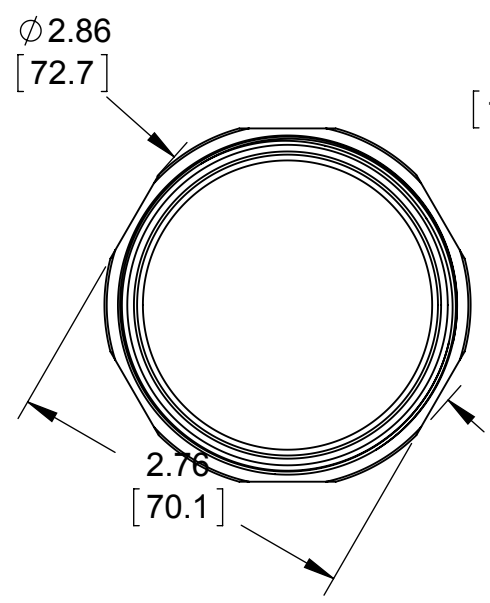
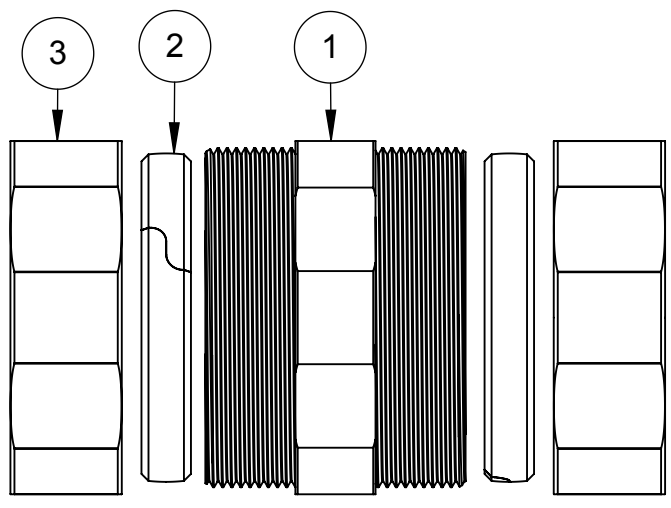
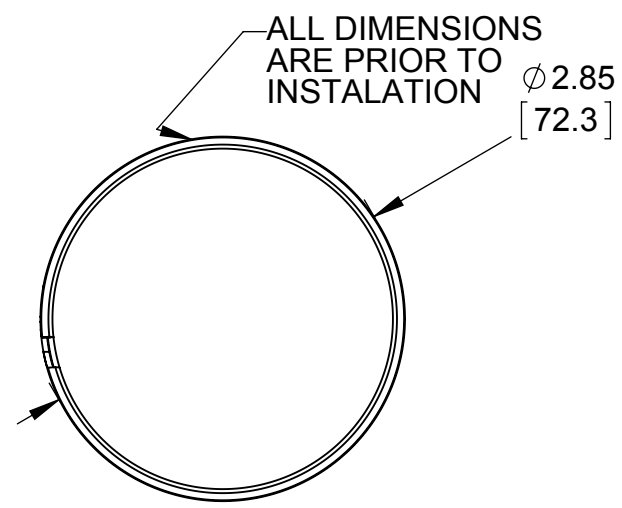
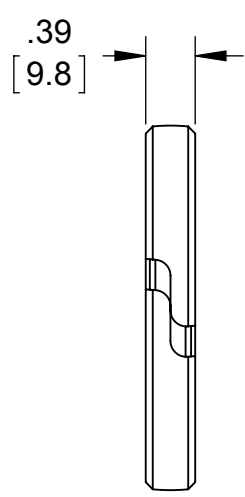
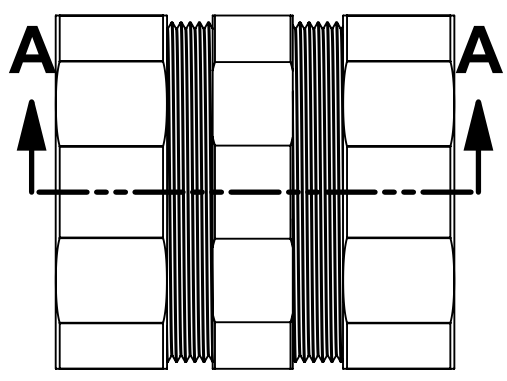
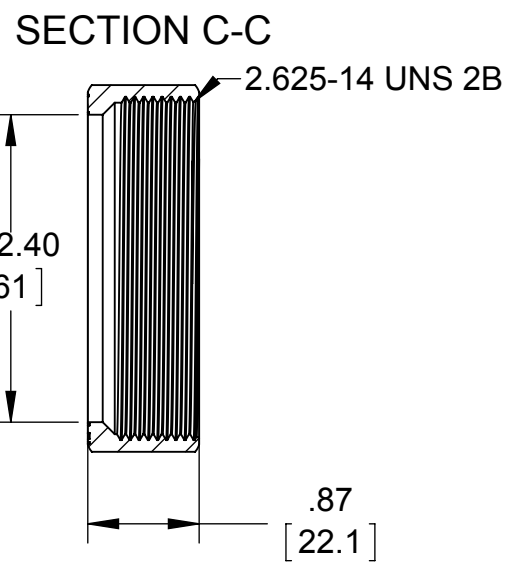
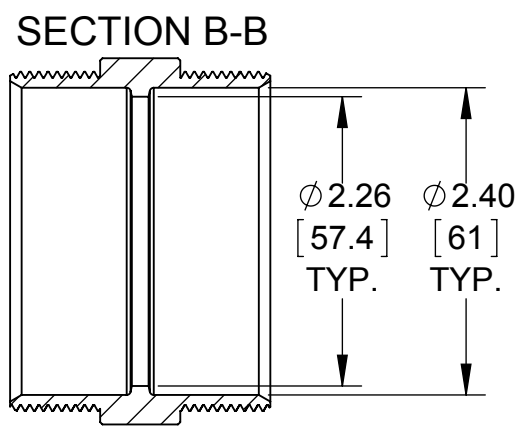

- NOTES:
1. ALL DIMENSIONS ARE IN INCHES AND [MILLIMETERS]
  2. COMPRESSION NUTS ARE TO BE TIGHTENED TO 1600 LBF-IN TORQUE
  3. CONCRETE TIGHT
  4. cULus® LISTED

SYM.	REVISION DESCRIPTION	APP	DATE
	INITIAL RELEASE	M.C.	10/26/2015

THE DESIGN AND DIMENSIONS OF THE PRODUCT SHOWN ON THIS DRAWING ARE SUBJECT TO CHANGE WITHOUT NOTICE

TITLE:  
**2" TRADE SIZE RIGID COMPRESSION COUPLER**

TOLERANCE UNLESS OTHERWISE SPECIFIED		<b>RACO</b> South Bend, Indiana	SCALE: <b>2:3</b>
.XX DECIMAL ±.015	DRAWN BY: <b>J.RICHARD</b>		
.XXX DECIMAL ±.005	APP. BY: <b>M.C.</b>		
ANGLE ±2°	DATE: <b>10/26/2015</b>		