

**LIST OF PARTS**

DESCRIPTION	MATERIAL	FINISH
SPACER	STEEL	GALVANIZED
SIDE	STEEL	GALVANIZED
SCREW	STEEL	GALVANIZED

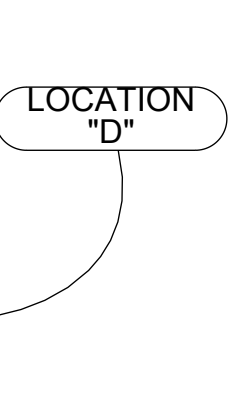
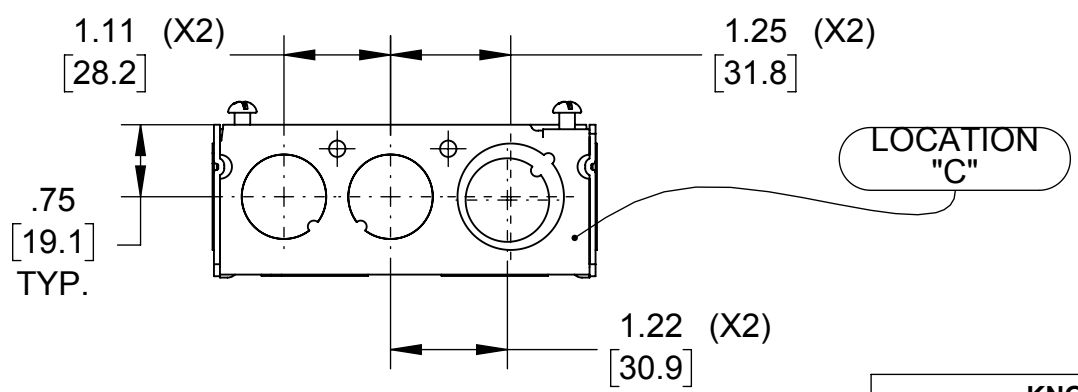
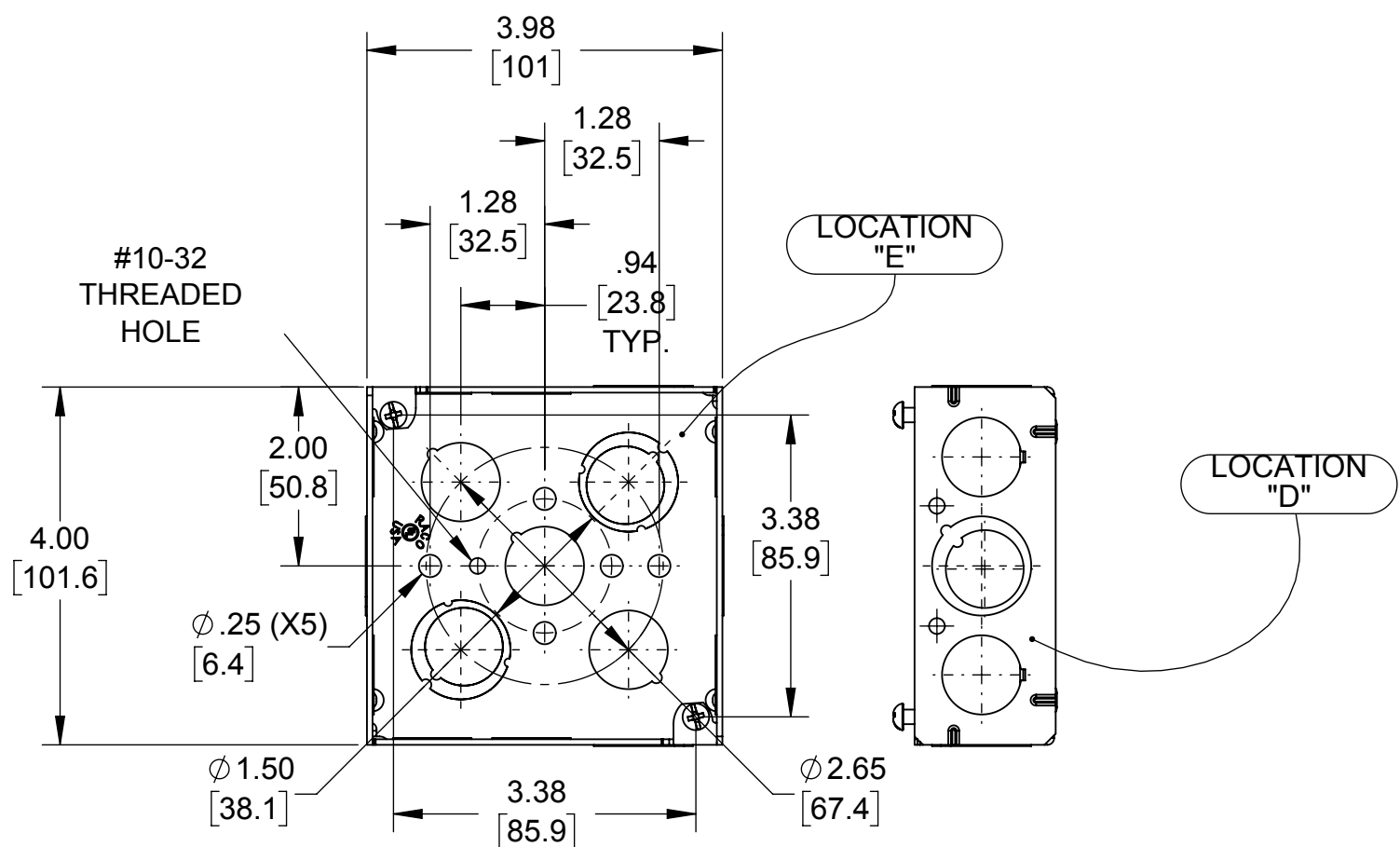
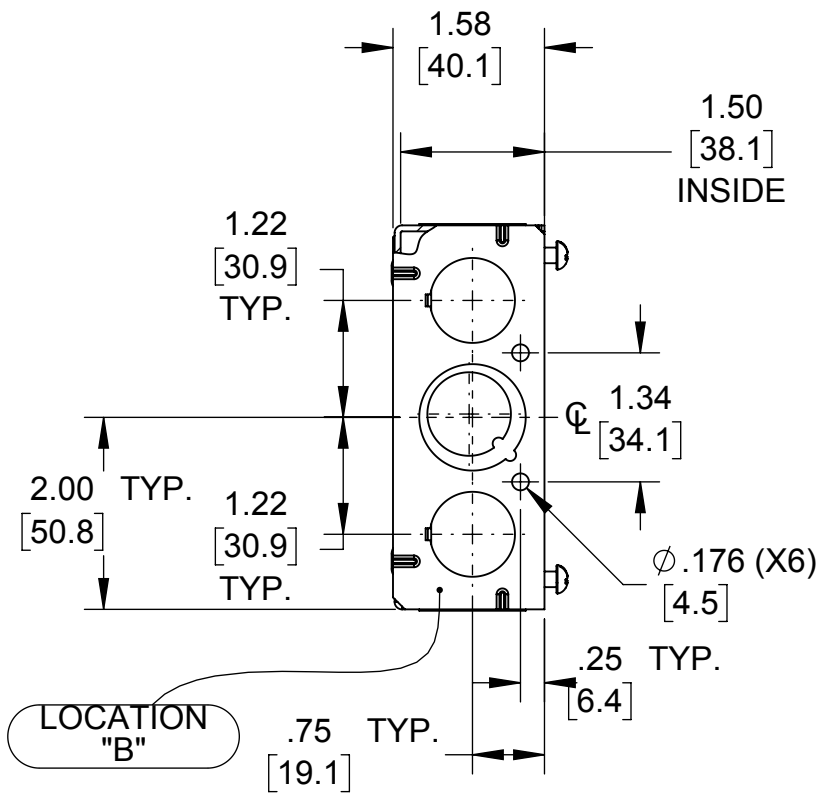
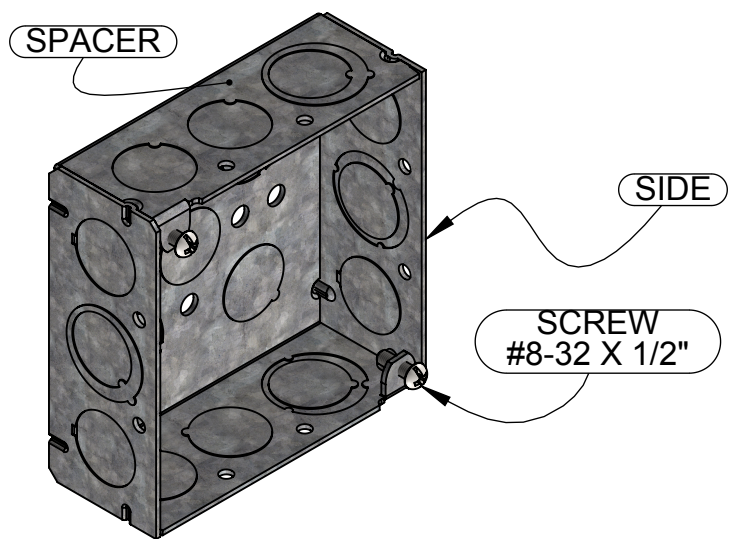

NOTES:  
 1. ALL DIMENSIONS ARE IN INCHES AND [MILLIMETERS]  
 2. BOX VOLUME: 21.0 IN<sup>3</sup> [344.1] CM<sup>3</sup>  
 3. UL® LISTED

KNOCKOUTS		
TRADE SIZE	LOCATION	QTY.
(1/2"-3/4") TKO®	E	2
(1/2"-3/4") TKO®	A,B,C,D	1
1/2" KO	E	3
1/2" KO	A,B,C,D	2

INITIAL RELEASE	N.S.	10-13-16
SYM.	REVISION DESCRIPTION	APP DATE

THE DESIGN AND DIMENSIONS OF THE PRODUCT SHOWN ON THIS DRAWING ARE SUBJECT TO CHANGE WITHOUT NOTICE

TITLE:  
**4" SQ, 1.5" DP BOX W/ (6) .75"TKO®, (11) .5"KO'S**

<b>RACO</b> South Bend, Indiana		
DRAWN BY:	J.R.	SCALE:
APP. BY:	N.S.	1:2
DATE:	10-13-16	

TOLERANCE UNLESS OTHERWISE SPECIFIED  
 .XX DECIMAL ±.015  
 .XXX DECIMAL ±.005  
 ANGLE ±2°