

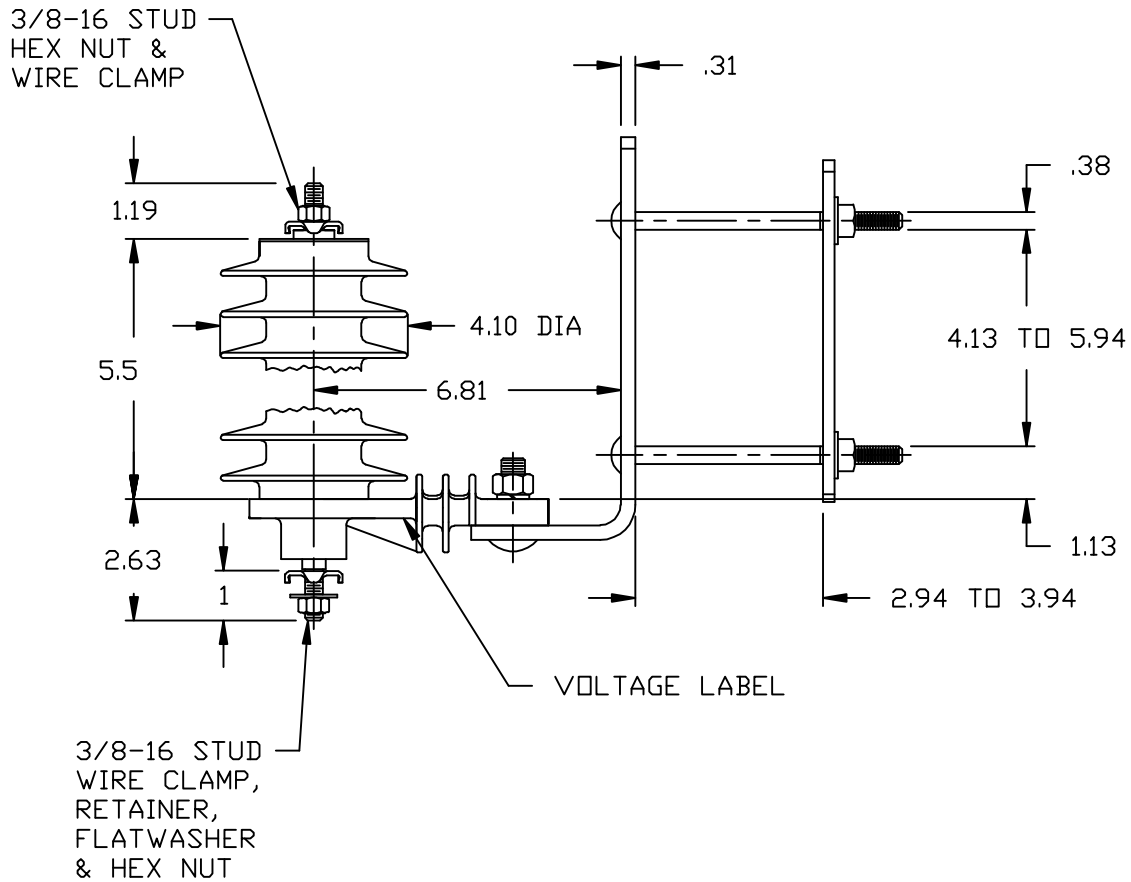

NOTES:

1. DIMENSIONS SUBJECT TO +/- 3% TOLERANCE
2. LEAKAGE DISTANCE (Inches) - 17
3. ALTITUDE 0-12000 FT. ABOVE SEA LEVEL
4. WEIGHT OF UNIT INCLUDING HARDWARE - 5.7 LB.
5. MAXIMUM CONTINUOUS LINE-TO-GROUND OPERATING VOLTAGE 10.2 kV MCOV
6. VOLTAGE RATING 12 kV RMS.



.5 μ SEC IR kV	10kA kV	500 A SWITCHING SURGE IR kV	MAXIMUM 8/20 DISCHARGE VOLTAGE - kV AT				
			1.5 kA	3.0 kA	5 kA	10 kA	20 kA
41.8		27.8	30.4	32.6	34.5	37.6	42.7

IEEE DISTRIBUTION HEAVY DUTY IEC DISTRIBUTION DH	CONFIDENTIAL: THIS DRAWING AND ITS CONTENTS ARE CONFIDENTIAL AND THE EXCLUSIVE PROPERTY OF HUBBELL POWER SYSTEMS. NO PUBLICATION, DISTRIBUTION OR COPIES MAY BE MADE WITHOUT THE WRITTEN CONSENT OF HUBBELL POWER SYSTEMS. HUBBELL POWER SYSTEMS UNPUBLISHED ALL RIGHTS RESERVED UNDER THE COPYRIGHT LAWS.	 HUBBELL® POWER SYSTEMS		
		TITLE PDV-100 OPTIMA 10.2 KV MCOV		
		SIZE S	DWG NO. ALES7XXX	CAT / PART / ASSY NO. 213710-7224
REV DATE 05/03/18	DO NOT SCALE THIS DRAWING	DRN BY PRO	DATE 06/17/00	SHEET 1 OF 1