

**NOTE:** FOR CABLE MANAGMENTS BEN INSTRUCTION SEE SHEET #2

**LIST OF PARTS**

DESCRIPTION	MATERIAL	FINISH
SPACER	STEEL	GALVANIZED
SIDES	STEEL	GALVANIZED
FASTENERS	STEEL	GALVANIZED
STAB-IT® CLAMPS	STEEL	GALVANIZED
PIG TAIL	COPPER	SEE NOTE
CABLE MANAGMENTS	STEEL	GALVANIZED

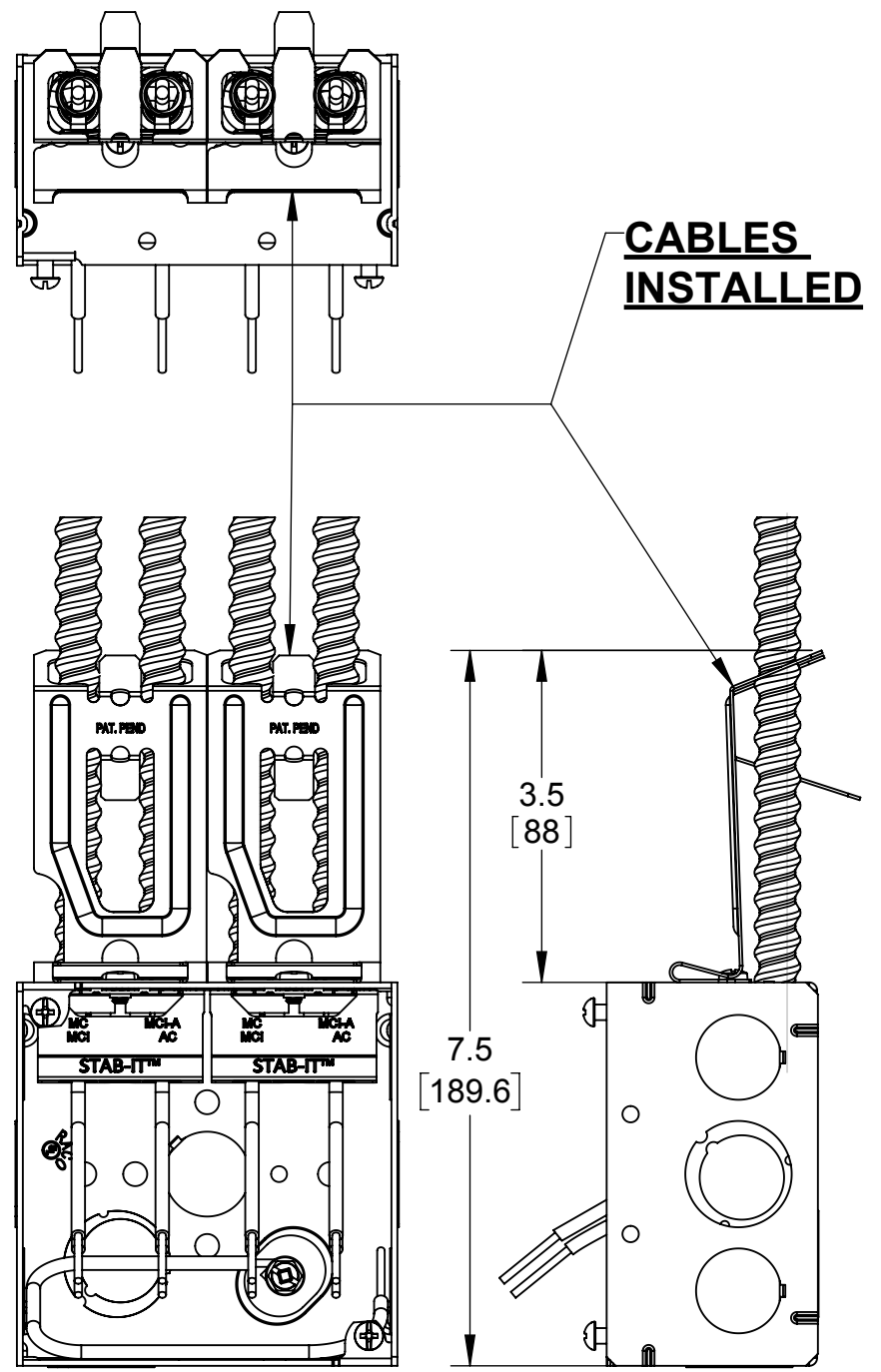
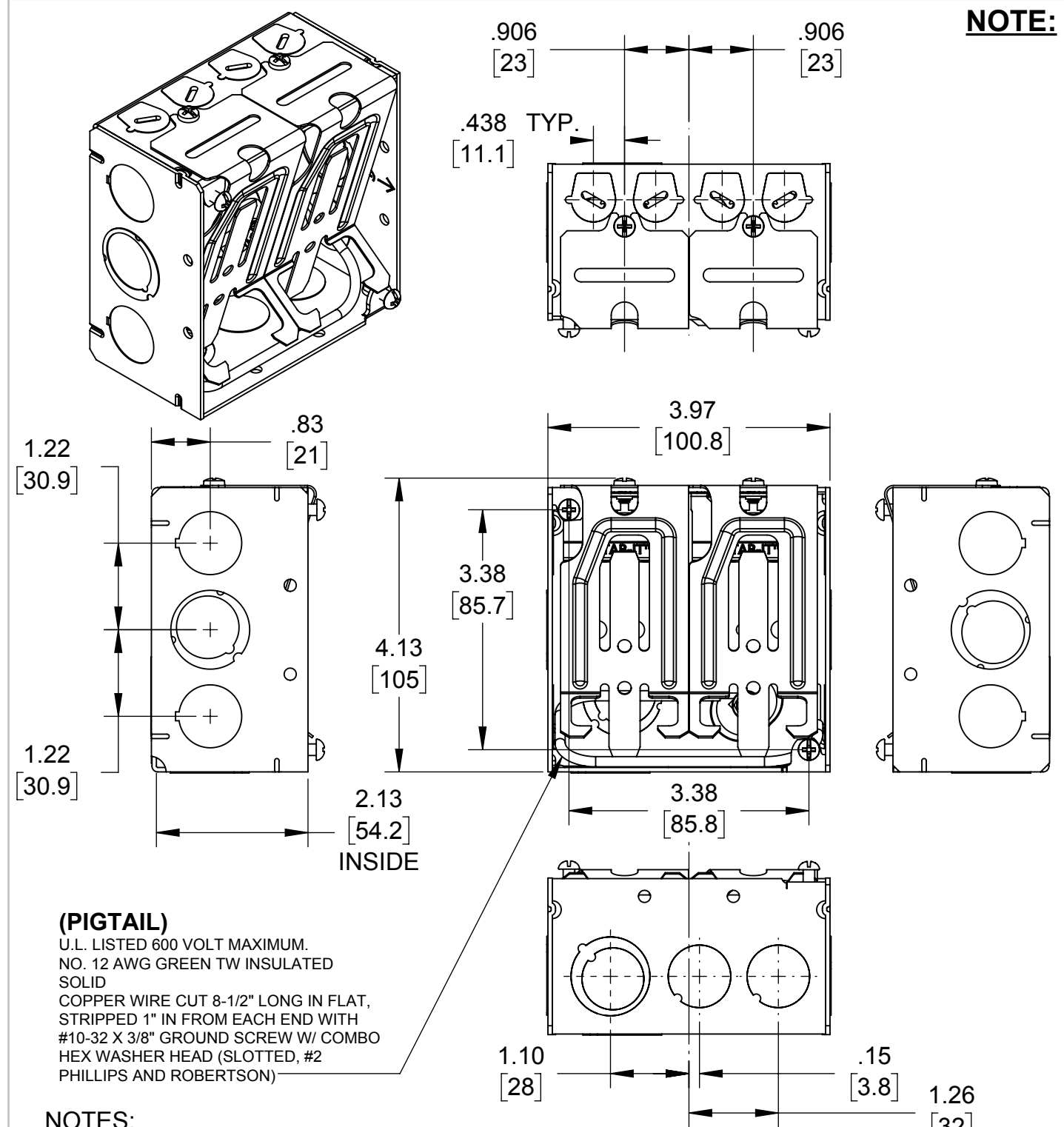

**(PIGTAIL)**  
 U.L. LISTED 600 VOLT MAXIMUM.  
 NO. 12 AWG GREEN TW INSULATED  
 SOLID  
 COPPER WIRE CUT 8-1/2" LONG IN FLAT,  
 STRIPPED 1" IN FROM EACH END WITH  
 #10-32 X 3/8" GROUND SCREW W/ COMBO  
 HEX WASHER HEAD (SLOTTED, #2  
 PHILLIPS AND ROBERTSON)

- NOTES:**
- ALL DIMENSIONS ARE IN INCHES AND [MILLIMETERS]
  - BOX VOLUME: 30.3 IN<sup>3</sup> [496.5 CM<sup>3</sup>]
  - 1 #12AWG SOLID COPPER WIRE 8" LONG PIG TAIL WITH GROUNDING SCREW INCLUDED
  - UL LISTED

KNOCKOUTS	
TRADE SIZE	LOCATION
1/2" KO	1- ON THE BOTTOM, 2-ON EACH SIDE, 2- ON THE BOTTOM SIDE OF THE SPACER
1/2", 3/4" TKO®	1- ON THE BOTTOM, 1-ON EACH SIDE, 1 -ON THE SIDE OF THE SPACER
CABLE PRIOUTS	4- ON THE TOP SIDE OF THE SPACER

CABLE TYPES AND RANGES FOR STAB-IT CLAMP	
CABLE TYPES	CABLE RANGES
AC STEEL & ALUMINUM	14-2,14-3,14-4,12-2,12-3,12-4,10-2,10-3
HCF AC STEEL	14-2,14-3,14-4,12-2,12-3,10-2,10-3
HCF AC ALMINUM	12-2,12-3,12-4,10-2,10-3
MC STEEL & ALUMINIUM	14-2,14-3,14-4,12-2,12-3,12-4,10-2,10-3
MCI-A STEEL & ALUMINIUM	14-2,14-3,14-4,12-2,12-3,12-4,10-2,10-3
HCF MCI-A STEEL	12-2,12-3,10-2
HCF MCI-A ALUMINIUM	14-2,14-3,14-4,12-2,12-3,12-4,10-2,10-3
3/8 TRADE SIZE FLEX,REFMFC CONDUIT STEEL & ALUMINUM. ANTI SHORT BUSHING REQUIRED	
CABLE RANGE .400" DIA. MIN TO .605" DIA. MAX	

SYMBOL	INITIAL RELEASE	K.K.	DATE
	REVISION DESCRIPTION	APP	DATE

THE DESIGN AND DIMENSIONS OF THE PRODUCT SHOWN ON THIS DRAWING ARE SUBJECT TO CHANGE WITHOUT NOTICE

**TITLE:**  
**4" SQ. 2-1/8" DEEP WELDED BOX WITH STAB-IT® BX/MC CABLE CLAMPS AND CABLE MANAGEMENT**

TOLERANCE UNLESS OTHERWISE SPECIFIED		<p><b>RACO</b>                  South Bend, Indiana</p>	<p>SCALE:  <b>1:2</b></p>
.XX DECIMAL ±.015	DRAWN BY: K.K.		
.XXX DECIMAL ±.005	APP. BY: N.S.		
ANGLE ±2°	DATE: 1/04/2017		

# Instructions For Using the RACO® Cable Support Bracket with STAB-IT® Boxes

**Step 1.** Install box to stud.

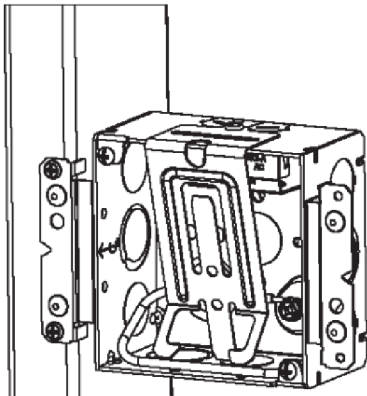

**Step 2.** Remove Pry-Out(s).

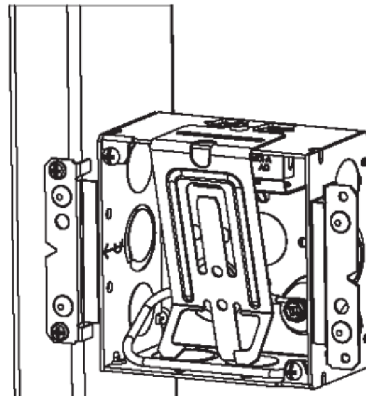

**Step 3.** Pre-bend Cable Support Bracket as shown and install cables.

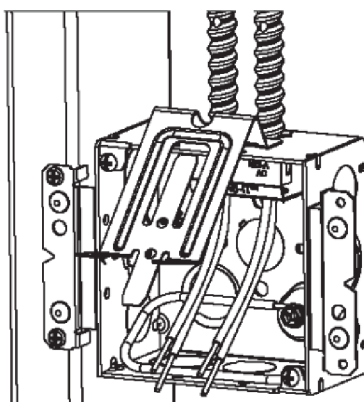

**Step 4.** Bend Cable Support Bracket as shown.

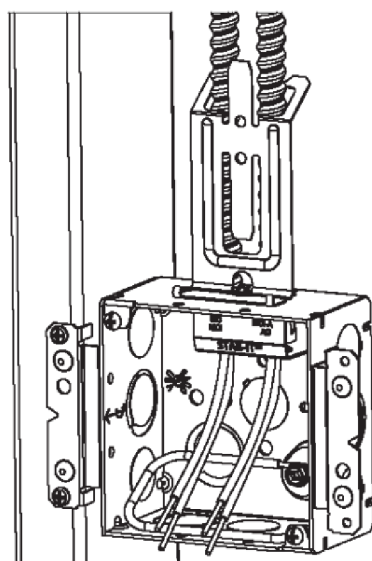

**Step 5.** Bend down two center tabs to lock cables as shown.

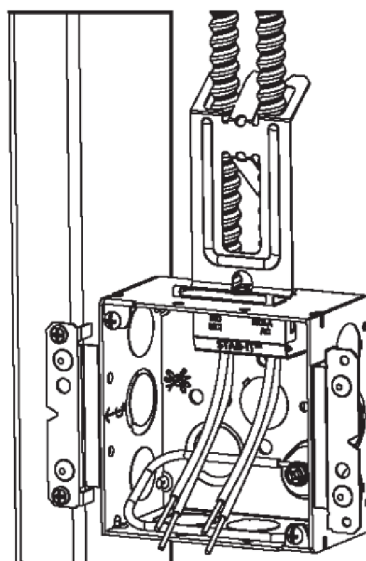

Hubbell Electrical Products  
Hubbell Incorporated (Delaware)

RACO INC.

3902 W. Sample St. P.O. Box 4002 South Bend, IN 46634

Phone: (574) 234-7151 FAX (574) 283-4244

MADE IN CHINA

RA-Instr 345

119088