

CAT. #	SIZE	A	B	C	D	E	F	G	H	J	K	L	M	N
2912RT	1/2" EMT	1.63 [41.4]	1.03 [26.2]	1.05 [26.7]	1.21 [30.7]	1.12 [28.4]	0.72 [18.3]	0.7 [17.8]	0.95 [24.1]	0.63 [16]	0.64 [16.3]	0.57 [14.5]	1/2"-14 NPSM	1/2-14 UNS
2913RT	3/4" EMT	1.76 [44.7]	1.28 [32.5]	1.26 [32]	1.39 [35.3]	1.35 [34.3]	0.95 [24.1]	0.93 [23.6]	1.17 [29.7]	0.82 [20.8]	0.87 [22.1]	0.76 [19.3]	3/4"-14 NPSM	3/4-14 UNS
2914RT	1" EMT	1.85 [47]	1.57 [39.9]	1.56 [39.6]	1.7 [43.2]	1.65 [41.9]	1.18 [30]	1.84 [46.7]	1.43 [36.3]	1.11 [28.2]	1.12 [28.4]	1.01 [25.7]	1" - 11 1/2 NPSM	1" - 14 UNS
2915RT	1-1/4" EMT	2.21 [54.1]	1.96 [49.8]	1.91 [48.5]	2.03 [51.6]	2.04 [51.8]	1.38 [35.1]	1.55 [39.4]	1.85 [47]	1.38 [35.1]	1.42 [36.1]	1.28 [32.5]	1 1/4" - 11 1/2 NPSM	1-1/4" - 14 UNS
2916RT	1-1/2" EMT	2.22 [56.4]	2.23 [56.6]	2.14 [54.4]	2.34 [59.4]	2.31 [58.7]	1.78 [45.2]	1.77 [45]	2.08 [52.8]	1.61 [40.9]	1.65 [41.9]	1.53 [38.9]	1 1/2" - 11 1/2 NPSM	1-1/2" - 14 UNS
2918RT	2" EMT	2.47 [62.7]	2.72 [69.1]	2.613 [66.4]	2.68 [68.1]	2.78 [70.6]	2.2 [55.9]	2.21 [56.1]	2.56 [65]	2.02 [51.3]	2.11 [53.6]	2.01 [51.1]	2" - 11 1/2 NPSM	2" - 14 UNS
2960RT	2-1/2" EMT	3.93 [99.8]	3.33 [84.6]	3.44 [87.4]	3.43 [87.1]	3.62 [91.9]	2.75 [69.9]	2.89 [73.4]	3.22 [81.8]	2.51 [63.8]	2.57 [65.3]	2.41 [61.2]	2 1/2" - 8 NPSM	2-1/2" - 11-1/2 UNS
2962RT	3" EMT	4.07 [103.4]	4.03 [102.4]	4.07 [103.4]	4.09 [103.9]	4.27 [108.5]	3.48 [88.4]	3.53 [89.7]	3.87 [98.3]	3.12 [79.2]	3.17 [80.5]	3.01 [76.5]	3" - 8 NPSM	3" - 11-1/2 UNS
2964RT	3-1/2" EMT	3.88 [98.6]	4.56 [115.8]	4.59 [116.6]	4.49 [114]	4.8 [121.9]	4.04 [102.6]	4.02 [102.1]	4.38 [111.3]	3.6 [91.4]	3.67 [93.2]	3.48 [88.4]	3 1/2" - 8 NPSM	3-1/2" - 11-1/2 UNS
2966RT	4" EMT	4.17 [105.9]	5.09 [129.3]	5.07 [128.8]	5 [127]	5.3 [134.6]	4.38 [111.3]	4.52 [114.8]	4.93 [125.2]	4.11 [104.4]	4.15 [105.4]	3.99 [101.3]	4" - 8 NPSM	4" - 11-1/2 UNS

TIGHTENING TORQUE			
TRADE SIZE OF FITTING	METRIC DESIGNATOR	TIGHTENING TORQUE	
		N-m	(lbf-in)
1/4a	10	19.8	175
3/8	12	22.6b	200
1/2	16	33.9	300
3/4	21	56.5	500
1	27	79.1	700
1-1/4	35	113	1000
1-1/2	41	136	1200
2	53	181	1600
2-1/2	63	181	1600
3	78	181	1600
3-1/2	91	181	1600
4	103	181	1600

a APPLIES TO FLEXIBLE CORD FITTINGS ONLY
b A 3/8 (12) TRADE-SIZE FITTING FOR USE WITH LIQUID-TIGHT FLEXIBLE METAL CONDUIT SHALL BE TIGHTENED WITH A TORQUE OF 26.5 N-M (235 LBF-IN).

LIST OF PARTS		
DESCRIPTION	MATERIAL	FINISH
CONNECTOR BODY	STEEL	GALVANIZED
COMPRESSION NUT	STEEL	GALVANIZED
LOCK NUT	STEEL	GALVANIZED
GLAND RING	STEEL	GALVANIZED
METAL RING	STEEL	GALVANIZED
INSULATED THROAT SEALING WASHER	NYLON 6/66	YELLOW
SEAL RING	POLY-PROPYLENE	CLEAR

NOTES:

1. ALL DIMENSIONS ARE IN INCHES AND [MILLIMETERS].
2. LOCKNUT SHALL BE HAND-TIGHTENED AND THEN FURTHER TIGHTENED 1/4 TURN WITH A HAMMER AND A FLAT BLADED SCREWDRIVER OR BY AN EQUIVALENT METHOD.
3. RAIN TIGHT.
4. cULus LISTED.

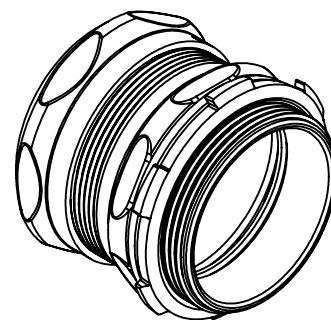

**ISOMETRIC VIEW
SCALE 1 : 2**

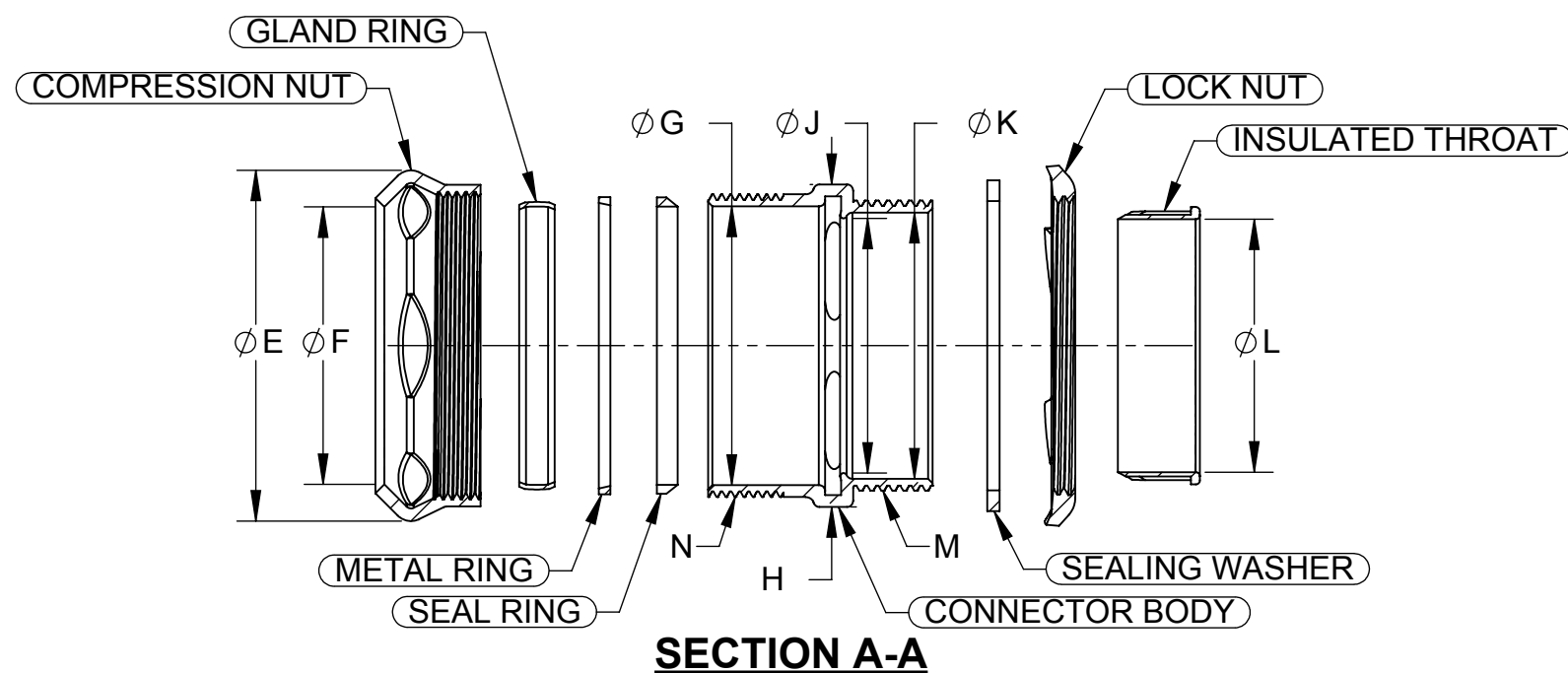
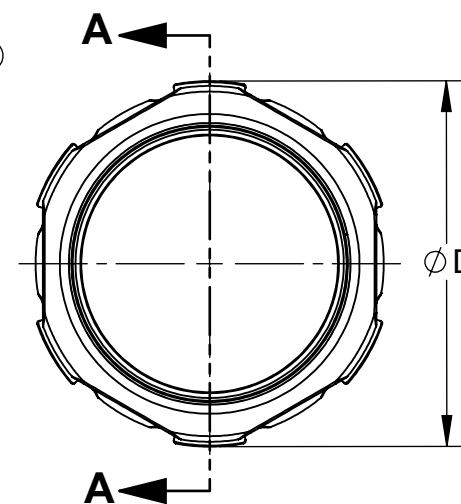
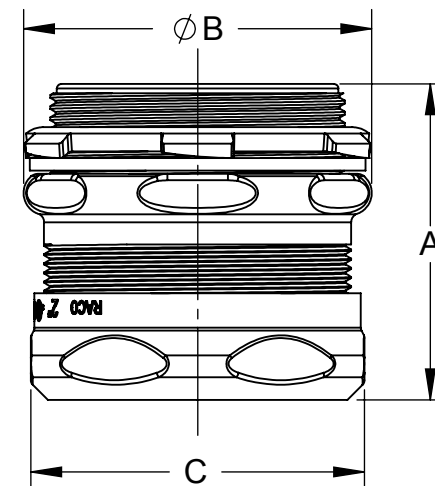

INITIAL RELEASE	F.P.	DATE
SYM.	REVISION DESCRIPTION	APP

THE DESIGN AND DIMENSIONS OF THE PRODUCT SHOWN ON THIS DRAWING ARE SUBJECT TO CHANGE WITHOUT NOTICE

TITLE:
COMPRESSION CONNECTOR-STEEL INSULATED CUS

TOLERANCE UNLESS OTHERWISE SPECIFIED

.XX DECIMAL ±.015
.XXX DECIMAL ±.005
ANGLE ±2°

RACO
South Bend, Indiana

DRAWN BY:	F.P.	SCALE:
APP. BY:	S.J.	2:3
DATE:	10/04/2016	