

REV.	DATE	DESCRIPTION	ECO	BY	C'H'K.
B	01/29/2014 00:00:00 AM	ADD NOTE 4 TO TABLE PER M/U.	34286	RB	LB

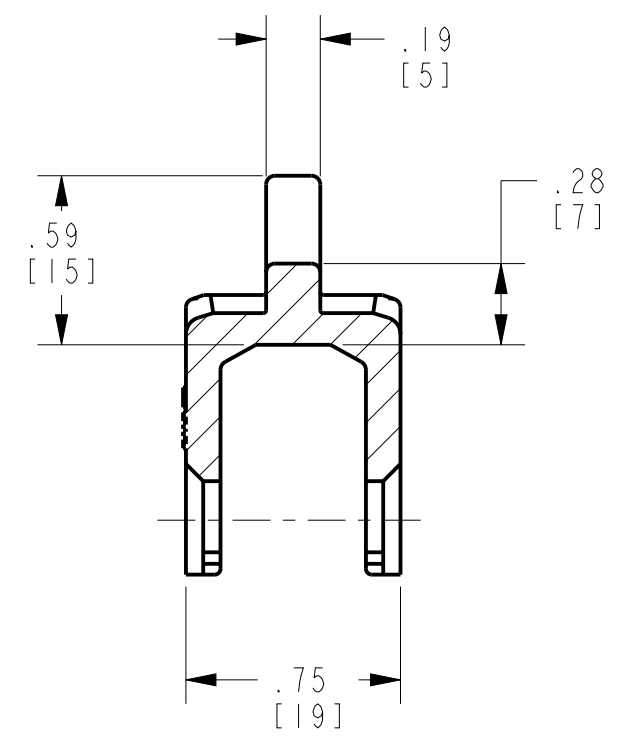

SECTION B-B

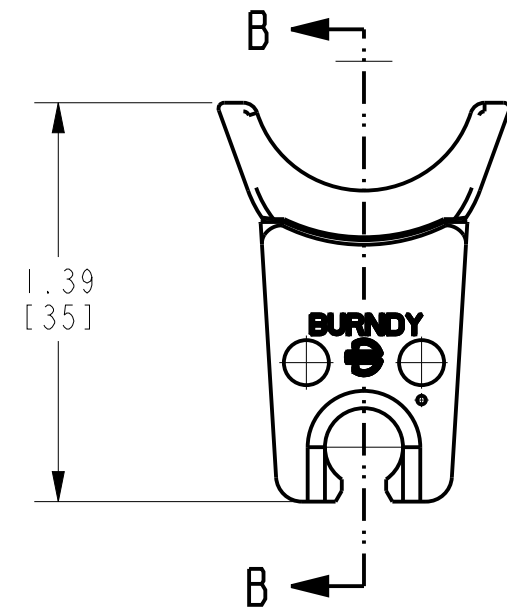
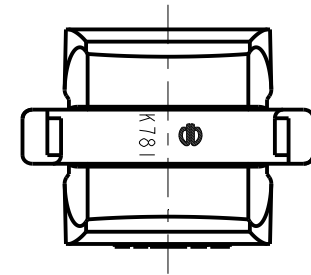
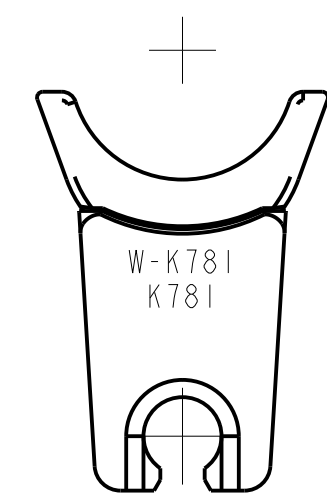

NOTES:

1. THIS DRAWING TO BE INTERPRETED PER ASME Y14.5M - 1994.
2. DIMENSIONS IN [] BRACKETS ARE IN MILLIMETERS, ROUNDED OFF TO THE NEAREST MILLIMETER, UNLESS OTHERWISE NOTED. METRIC DIMENSIONS ARE FOR REFERENCE ONLY.
3. MATERIAL: STAINLESS STEEL.
4. DIE GAGE CAT. NO. WPGK781.

TO ORDER BURNDY® PRODUCTS CALL		W-DIES (MD6 HYTOOL™)	
UNITED STATES: 1-800-346-4175 (LONDONDERRY, NH)		ITEM NO: N/A	
CANADA: 1-800-361-6975 (QUEBEC) 1-800-387-6487 (ALL OTHER PROVINCES)		CAT. NO: WK781	
FOR PRODUCT INFO: http://www.burndy.com		DRAWN BY: S JEYAGANESH 06/19/2010	
		CHECKER: R ROMAN 06/23/2010	
		DSN APPVL: R ROMAN 06/23/2010	
		MFG APPVL: --	
		QA APPVL: J BRODEUR 06/29/2010	
		MKT APPVL: R POIRIER 06/23/2010	
		PROJ FAM: MECHANICAL/W-DIES	
		PROJECT #: --	
		SIZE: B	
		DOCUMENT TYPE: Sales	
		REL LEVEL: Released	
		SCALE: 3:2	
		DRAWING NO: 30001789	
		REV: B	
		SHEET 1 OF 1	

REV: PE0200