

\*\*\* BILL OF MATERIAL \*\*\*

PT NO.	QTY	DESCRIPTION	REFERENCE
1	1	CL501TN; TINNED COPPER LAY-IN LUG	SC212515-01
2	1	#10-32 HEX. WASHER HEAD MACHINE SCREW, THREAD CUTTING, TYPE F, S.S.	ANSI B18.6.4
3	1	#10 EXTERNAL TOOTH LOCK WASHER, S.S.	ANSI B18.21.1

FIELD WIRING USE #14-4 AWG CU; SOL. OR STR.		MOUNTING HOLE SIZE
CONDUCTOR SIZE	TIGHTENING TORQUE	#21 DRILL (.159")  TORQUE TO 25 IN-LBS
14-10 AWG	20 INCH-LBS	
8 AWG	25 INCH-LBS	
6-4 AWG	35 INCH-LBS	

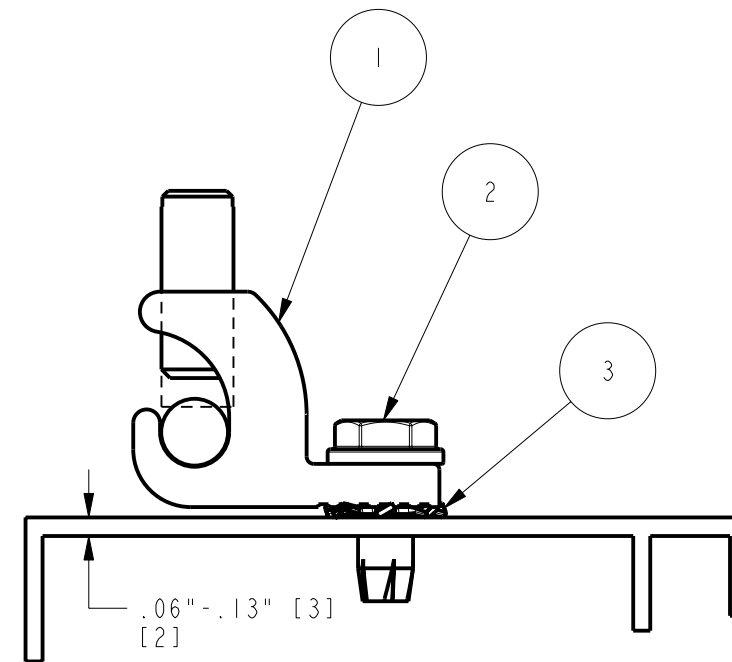

ANODIZED ALUMINUM INSTALLATION

NOTES:

- REFER TO DRAWING SC212515 FOR DIMENSIONS OF CONNECTOR.
- ALL HARDWARE IS 300 SERIES OR 18-8 STAINLESS STEEL.
- UL LISTED AND CSA CERTIFIED GROUNDING AND BONDING EQUIPMENT AND RATED FOR DIRECT BURIAL IN CONCRETE OR EARTH.  
UL LISTED GROUND LUGS AND DEVICES FOR USE WITH PHOTOVOLTAIC MODULES AND PANELS.
- DIMENSIONS IN BRACKETS [ ] ARE IN MILLIMETERS AND ARE FOR REFERENCE ONLY.
- SEE ITEM NUMBER: 50061563 FOR INSTALLATION INSTRUCTIONS AND RATINGS.

TO ORDER BURNDY® PRODUCTS CALL		LAY-IN LUG, TINNED COPPER W/ SS HARDWARE	
UNITED STATES:		ITEM NO: 30001905	
1-800-346-4175 (LONDONDERRY, NH)		CAT. NO: CL501TNMHWSST	
CANADA:		DRAWN BY: M KATHIR 10/28/15	
1-800-361-6975 (QUEBEC)		CHECKER: R ROMAN 12/22/15	
1-800-387-6487 (ALL OTHER PROVINCES)		DSN APPVL: R ROMAN 12/22/15	
FOR PRODUCT INFO: <a href="http://www.burndy.com">http://www.burndy.com</a>		MFG APPVL: -- --	
		QA APPVL: C KOWALCZYK 12/16/15	
		MKT APPVL: P THERRIEN 12/22/15	
		SCALE: 3:4	
		PROJ. FAM: MECHANICAL GROUNDING	
		DRAWING NO	
		30001906	
		REV	
		E	
		SHEET 1 OF 1	

REV.	DATE	DESCRIPTION	ECO	BY	C/H/K
E	10/24/2015 00:00:00 AM	UPDATE CL501, CL501TN, AND KIT SALES DRAWINGS.	41982	MK	RR

REV: PE0200