

DRAWING NO.
30007941

4

3

2

1

CATALOG NUMBER	ITEM NUMBER	L
B33G144NTN	10058274	14.00 [356]
B33G334NTN	10058275	33.00 [838]
B33G364NTN	30006045	36.00 [914]
B33G394NTN	10058276	39.00 [991]
B33G474NTN	50129040	47.00 [1194]
B33G594NTN	50128421	59.00 [1499]
B33G794NTN	50128422	79.00 [2007]

REV	DATE	DESCRIPTION	ECO	BY	C'H'K.
D	2022-06-22 00:00:00 EDT	UPDATED AS PER MARKUP	220616021261	YR	RA

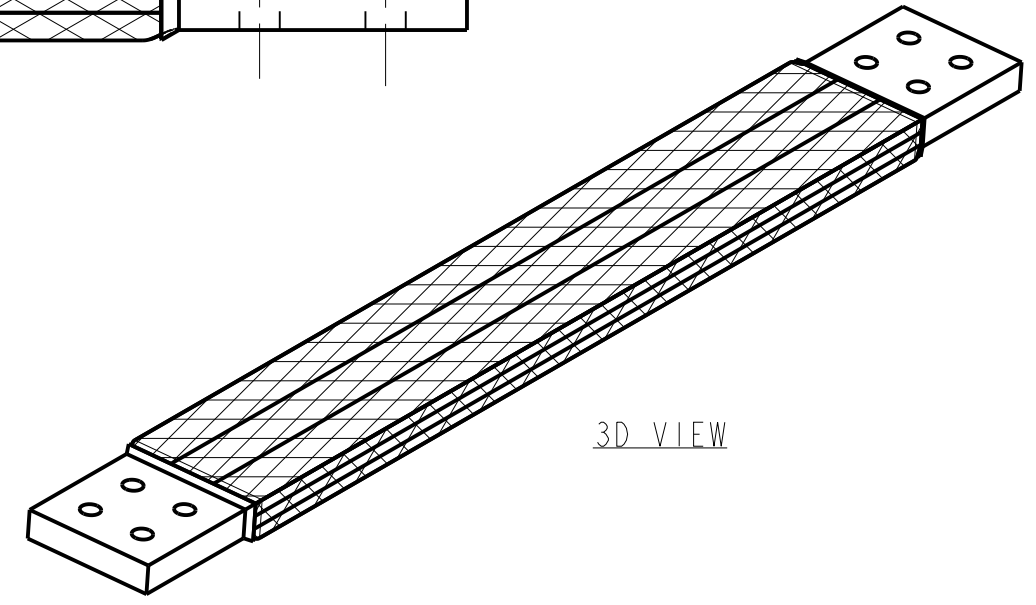
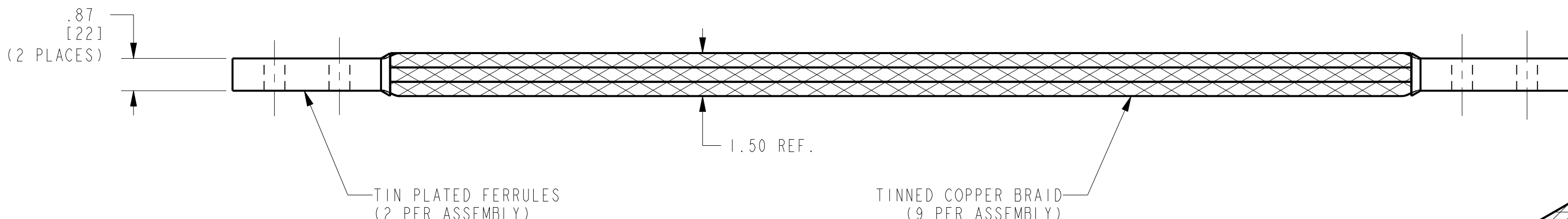
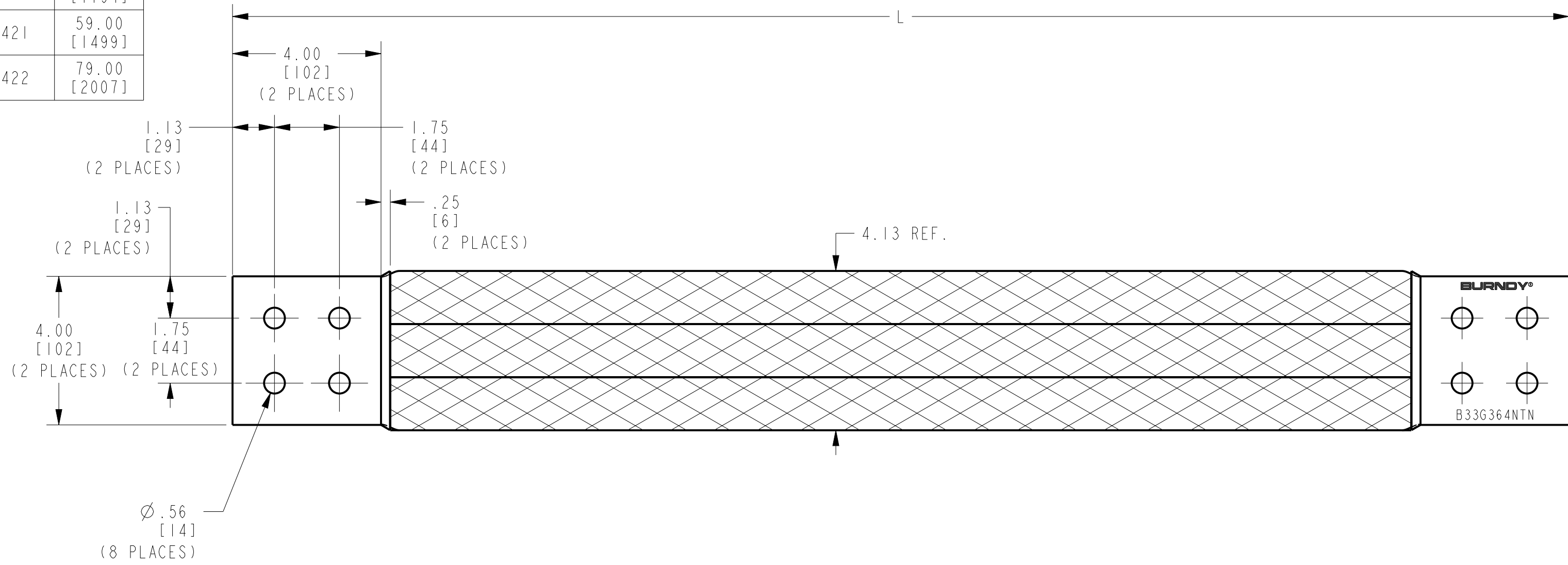

- NOTES:
- MATERIAL:
BRAIDS-TIN PLATED COPPER
FERRULES-TIN PLATED COPPER
 - DIMENSIONS IN BRACKETS [] ARE IN MILLIMETERS ROUNDED OFF TO THE NEAREST MILLIMETER, UNLESS OTHERWISE SPECIFIED, AND ARE FOR REFERENCE ONLY.
 - APPROXIMATE AMP RATING: 2500 A INDOOR, 3000 A OUTDOOR
THIS MAY VARY WITH AMBIENT CONDITIONS, ORIENTATION OF THE BRAID AND OTHER SERVICE CONDITIONS.

4 SUFFIX "TN" DENOTES TIN PLATING.

TO ORDER BURNDY® PRODUCTS CALL
UNITED STATES:
1-800-346-4175 (LONDONDERRY, NH)
CANADA:
1-800-361-6975 (QUEBEC)
1-800-387-6487 (ALL OTHER PROVINCES)
FOR PRODUCT INFO: <http://www.burndy.com>

BRAID	
ITEM NO:	SEE TABLE
CAT. NO:	B33G--4NTN (SEE TABLE)
DRAWN BY:	C. RAJEEV 11/8/10
CHECKER:	K. BOUTIN 11/15/10
DSN APPVL:	K. BOUTIN 11/15/10
MFG APPVL:	P. THERRIEN 11/12/10
QA APPVL:	J. BRODEUR 11/23/10
MKT APPVL:	--
PROJ #:	--
DOCUMENT TYPE:	Sales
REL LEVEL:	Released
SCALE:	3:4
DRAWING NO:	30007941
REV:	D
SHEET 1 OF 1	

4

3

2

1

REV: CREO_05/20/21