

DRAWING NO.  
30010219

REV	DATE	DESCRIPTION	ECO	BY	C'H'K.
A	1/7/2011 5:30:00 AM	FOCUS REQUEST	23102	AD	MA

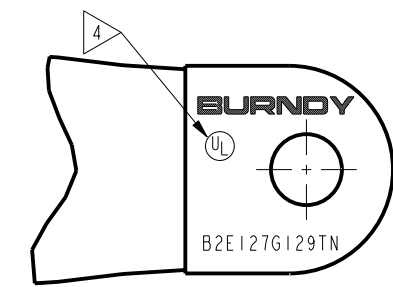

DETAIL A  
SCALE 3:2

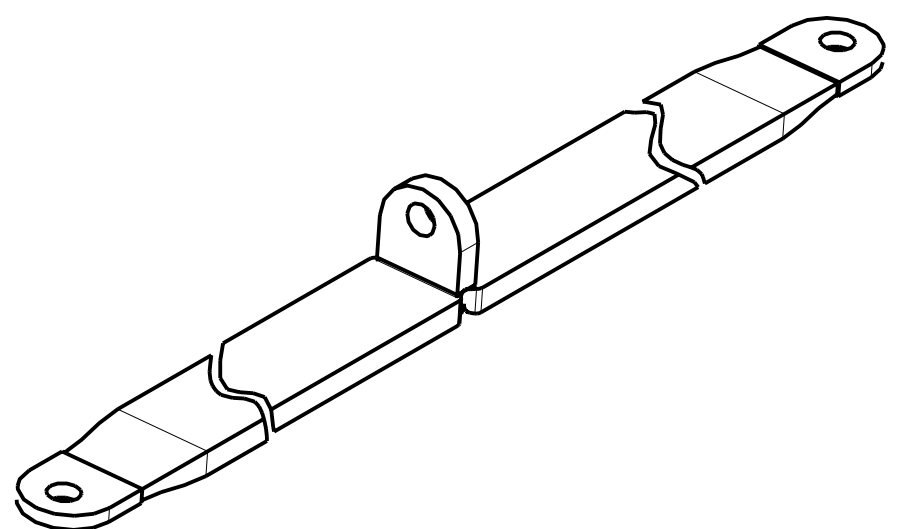
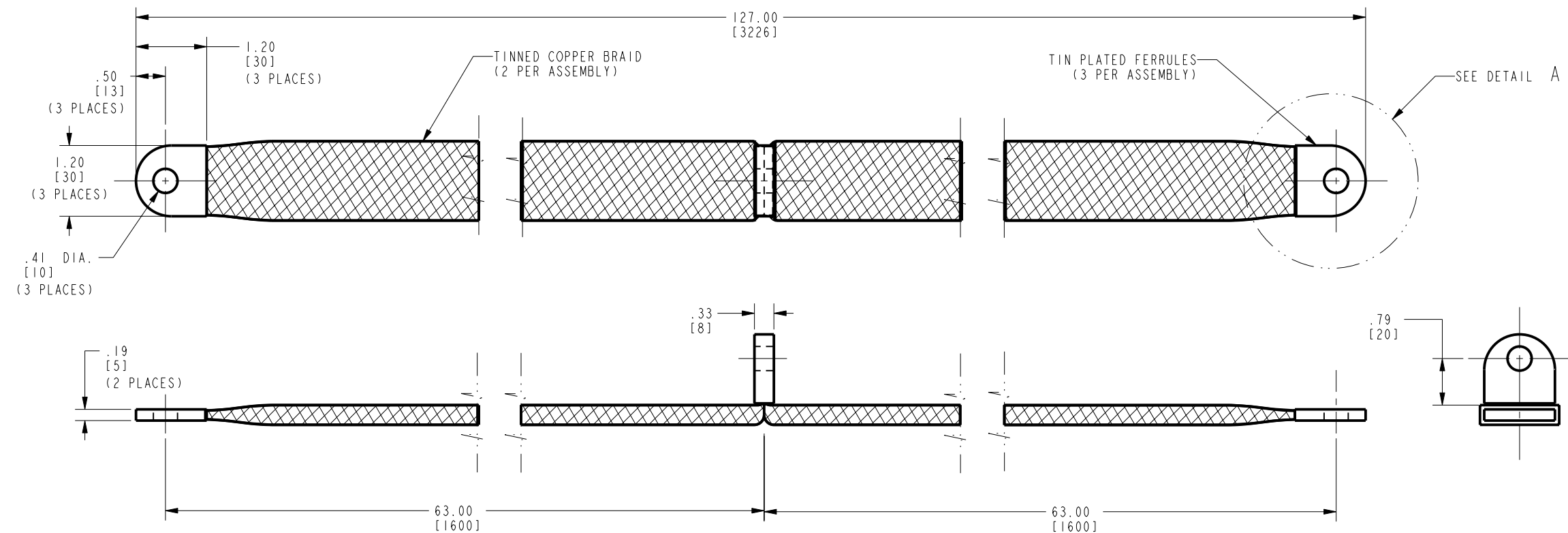

NOTES:

1. FINISH: HOT TIN DIPPED.
  2. DIMENSIONS IN BRACKETS [ ] ARE IN MILLIMETERS ROUNDED OFF TO THE NEAREST MILLIMETER, UNLESS OTHERWISE SPECIFIED, AND ARE FOR REFERENCE ONLY.
  3. APPROXIMATE AMP. RATING 340A INDOOR, 405A OUTDOOR. THIS RATING MAY VARY WITH AMBIENT CONDITIONS, ORIENTATION OF THE BRAID, AND OTHER SERVICE CONDITIONS.
- 4 ALL SIZES ARE LISTED TO UL767 GROUNDING & BONDING EQUIPMENT STANDARDS.

TO ORDER BURNDY® PRODUCTS CALL		BRAID, FLEXIBLE	
UNITED STATES: 1-800-346-4175 (LONDONDERRY, NH)		ITEM NO: 30006130	
CANADA: 1-800-361-6975 (QUEBEC) 1-800-387-6487 (ALL OTHER PROVINCES)		CAT. NO: B2E127G129TN	
FOR PRODUCT INFO: <a href="http://www.burndy.com">http://www.burndy.com</a>		DRAWN BY: AUGUSTIN.S 01/07/11	
		CHECKER: E.MARTIN 01/24/11	
		DSN APPVL: E.MARTIN 01/24/11	
		MFG APPVL: O.GUALBERTO 01/25/11	
		QA APPVL: C.ACKERMAN 01/24/11	
		MKT APPVL: --	
		SCALE: 3:4	
PROD FAM: MECHANICAL GROUNDING		DRAWING NO	
PROJECT #: --		30010219	
DOCUMENT TYPE: Sales		SHEET 1 OF 1	
REL LEVEL: Released		REV	
		A	

REV: PE0200