

REV	DATE	DESCRIPTION	ECO	BY	CHK.
A	2018-09-06 01:00:00 EDT	DRAWING RELEASED	49753	JL	BE

CATALOG NO.

STRANDED COPPER ACCOMODATED

BOLT SIZE

METRIC BOLT SIZE

INSTALLATION TOOLING (# CRIMPS)										DIELESS (# CRIMPS)	WIRE STRIP LENGTH
DIE INFORMATION			HYDRAULIC				DIELESS (# CRIMPS)	WIRE STRIP LENGTH			
COLOR CODE	DIE INDEX	TYPE	Y46	Y45	Y48B	Y60BHU			HYDRAULIC : Y644M(I) BAT644M(I)	3-1/16"	
		WHITE DIE SET	P44RT(4)	S44RT(4)	C44R(2)	L44RT(2)					
		NEST	P44D(2)	---	C44D(2)	---					
		INDENTOR	P44PR		Y48PR						

D

YA442NDTSSV

1000 kcmil
--
500mm² STR (28.3)

1/2

M12

WHITE
27

WHITE DIE SET

P44RT(4)

S44RT(4)

C44R(2)

L44RT(2)

D

C

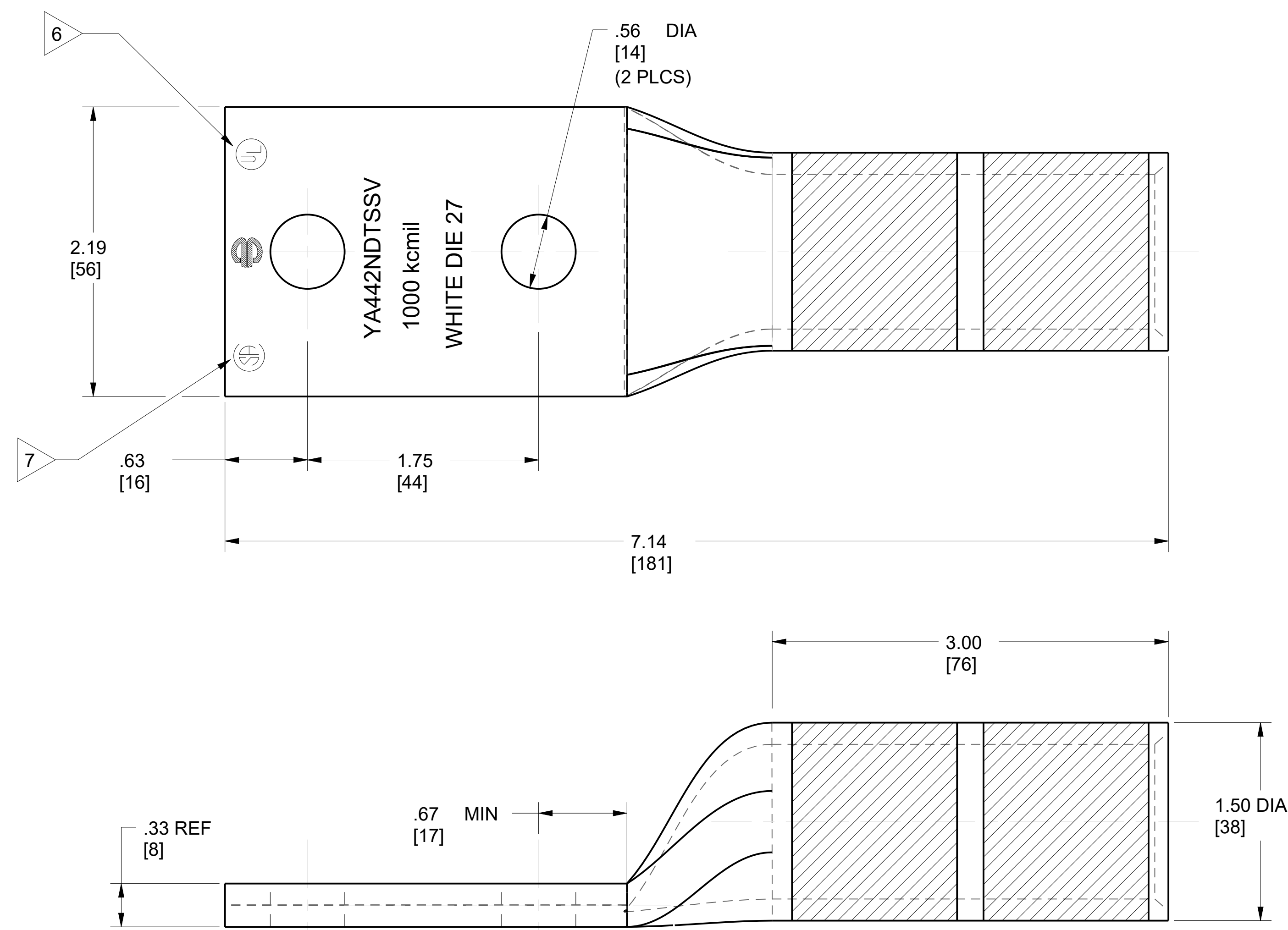

B

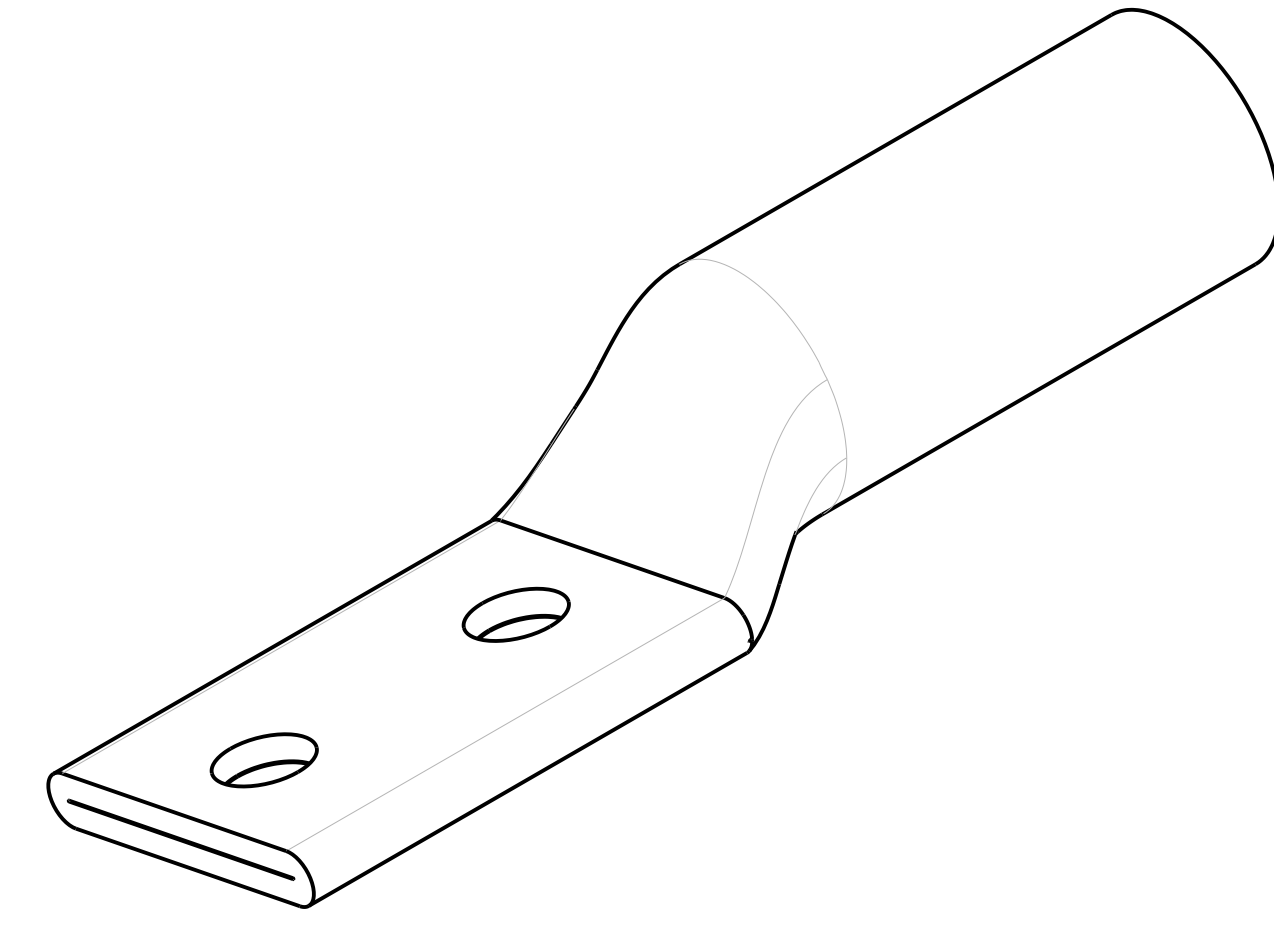

C

B

NOTES:

1. MATERIAL: COPPER TUBING
2. FINISH: SILVER PLATED.
3. CATALOG # PT6515 ADAPTOR IS REQUIRED TO USE "U" DIES IN Y45 SERIES TOOLS.
4. CATALOG # PUADP-1 ADAPTOR IS REQUIRED TO USE "U" DIES IN Y46 SERIES TOOLS.
5. DIMENSIONS IN BRACKETS [] ARE IN MILLIMETERS ROUNDED OFF TO THE NEAREST MILLIMETER, UNLESS OTHERWISE NOTED, METRIC DIMENSIONS ARE FOR REFERENCE ONLY.
6. CONNECTORS ARE UL LISTED.
7. CONNECTORS ARE CSA CERTIFIED.
8. "DTS" IN CATALOG NUMBER INDICATES SOLDER SEALED.

A

REV: PE0200

TO ORDER BURNDY® PRODUCTS CALL		HYLUG™	
UNITED STATES 1-800-346-4175 (LONDONDERRY, NH)		ITEM NO: 30006193	CAT. NO: YA442NDTSSV
CANADA: 1-800-361-6975 (QUEBEC) 1-800-387-6487 (ALL OTHER PROVINCES)		DRAWN BY: B.DURAICHAMY 03/04/11	CHECKER: B.ELLIS 09/06/18
FOR PRODUCT INFO: http://www.burndy.com		DSN APPVL: R.ROMAN 09/12/18	MFG APPVL: J.MICHAUD 09/13/18
		QA APPVL: T.WATTS 09/12/18	MKT APPVL: --
		PROD FAM: CM&R COMPRESSION	DRAWING NO: 30012929
		PROJECT #: FPN1710097	SIZE: D
		DOCUMENT TYPE: Sales	SHEET 1 OF 1
		REL LEVEL: Released	SCALE: 3:2

A