

REV	DATE	DESCRIPTION	ECO	BY	C'H'K.
A	2011-08-10 01:00:00 EDT	NEW DRAWING RELEASE	25306	AB	MB

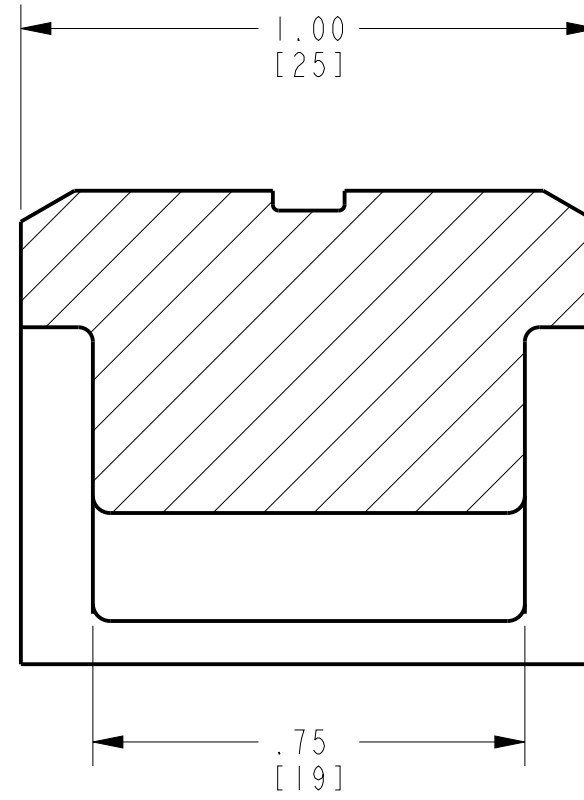

SECTION A-A

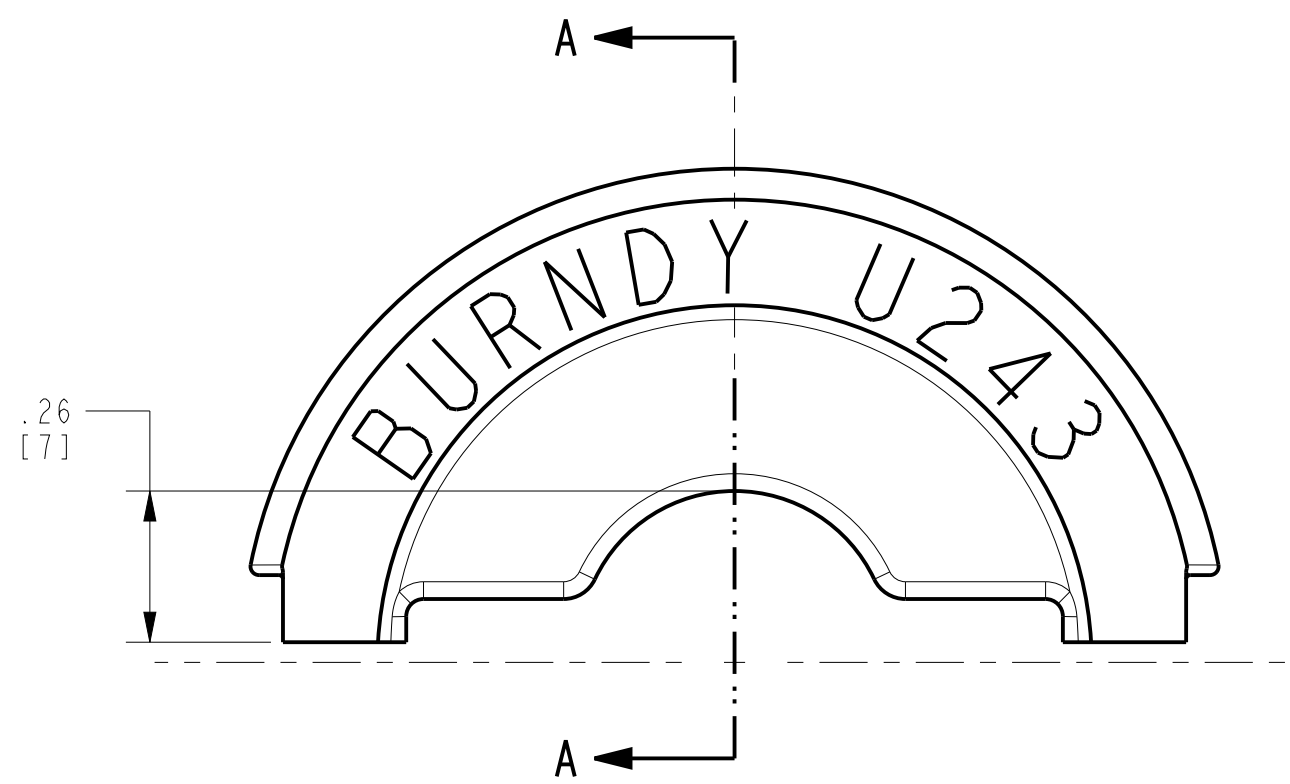
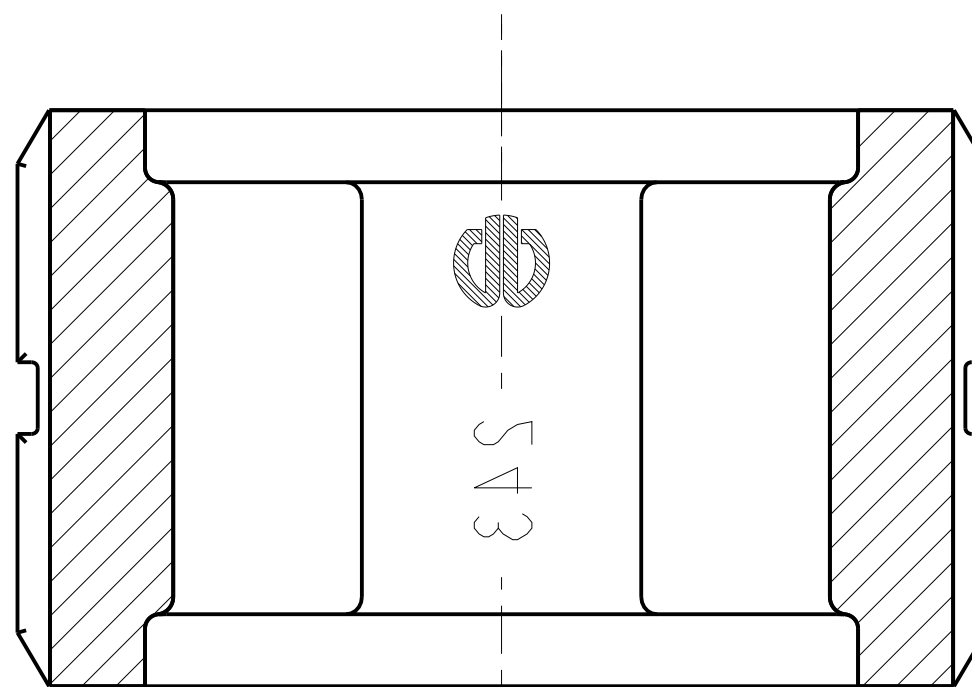
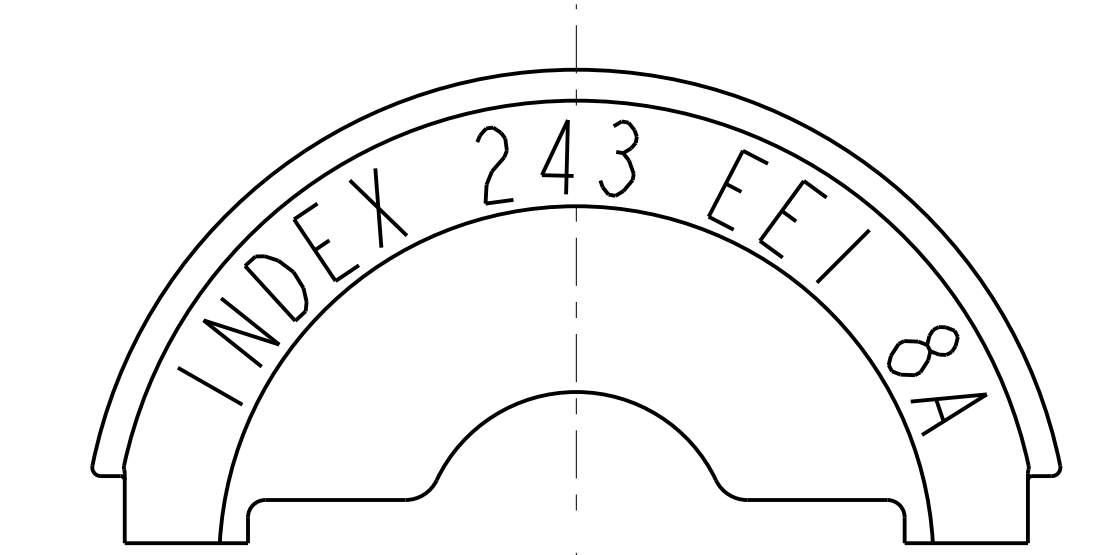

NOTES:

1. DIMENSIONS IN BRACKETS [ ] ARE IN MILLIMETERS, ROUNDED TO THE NEAREST MILLIMETER AND ARE FOR REFERENCE ONLY
2. DIE INSPECTION GAGE CATALOG NUMBER: CONSULT FACTORY.
3. MATERIAL: STAINLESS STEEL

TO ORDER BURNDY® PRODUCTS CALL UNITED STATES: 1-800-346-4175 (LONDONDERRY, NH) CANADA: 1-800-361-6975 (QUEBEC) 1-800-387-6487 (ALL OTHER PROVINCES) FOR PRODUCT INFO: <a href="http://www.burndy.com">http://www.burndy.com</a>		CIRCULAR BUTTING TWIN DIE	
		ITEM NO: 420243	
DRAWN BY: A.BALAMURUGAN 08/10/11 CHECKER: P.WASON 08/09/11 DSN APPVL: P.WASON 08/09/11 MFG APPVL: -- QA APPVL: J.BORDEUR 08/15/11 MKT APPVL: R.POIRIER 08/09/11 PROD FAM: -- PROJECT #: -- DOCUMENT TYPE: Sales REL LEVEL: Released		CAT. NO: U243	
		SCALE: 3:1	
		DRAWING NO	
		REV	
		30017993	
		A	
		SHEET 1 OF 1	
		C	
		A	
		A	

REV: PE0200