

REV	DATE	DESCRIPTION	ECO	BY	C'H'K.
B	06/03/2016 00:00:00 AM	FOCUS FPN1605077	44007	ARJ	MB

CATALOG NO.	CONDUCTOR		BOLT SIZE	INSTALLATION TOOLING (# CRIMPS)							WIRE STRIP LENGTH
	FLEX	CODE (AWG)		DIE INDEX	COLOR CODE	MECHANICAL		HYDRAULIC		DIE NUMBER (# OF CRIMPS)	
						MD7-34R, MD6, OUR840,	BCT500HS Y500CTHS	Y750, Y35, Y46, Y39 PAT750	Y45		
YAZV252TC38FXSL	1/0 FLEX CLASSES G, H, I, K, M (275/24) DLO	1/0 AWG CLASS B, C	3/8 [M10]	12 OR 348	PINK	W25VT X25RT W25RT (4)	W25VT X25RT W25RT (4)	U25RT (2)	U25RT (2)	MY29-11 (2) Y644HS (1) Y81KFTMBH (2) Y81KFT (2) PAT81KFT-18V (2)	1-9/16

D

D

C

C

B

B

A

A

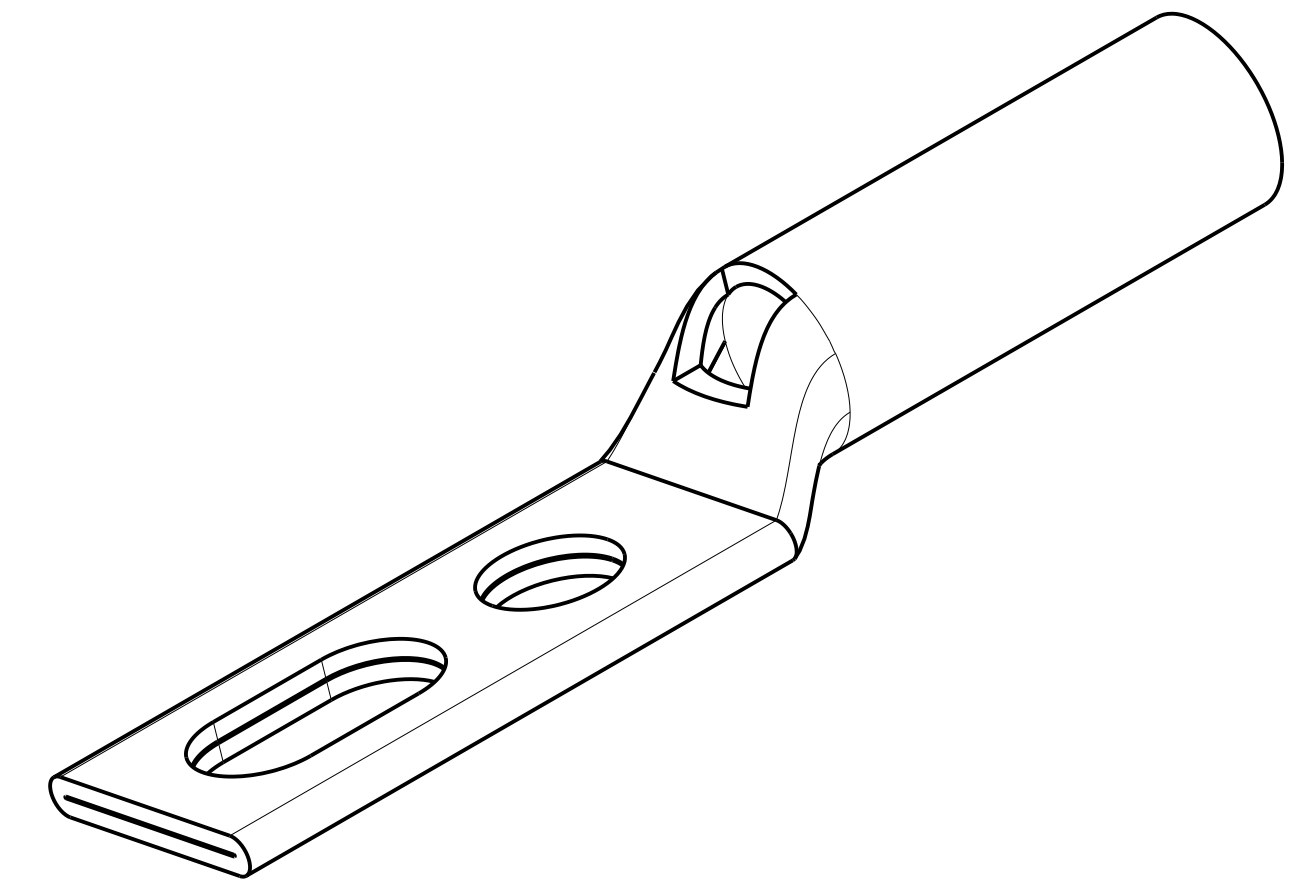
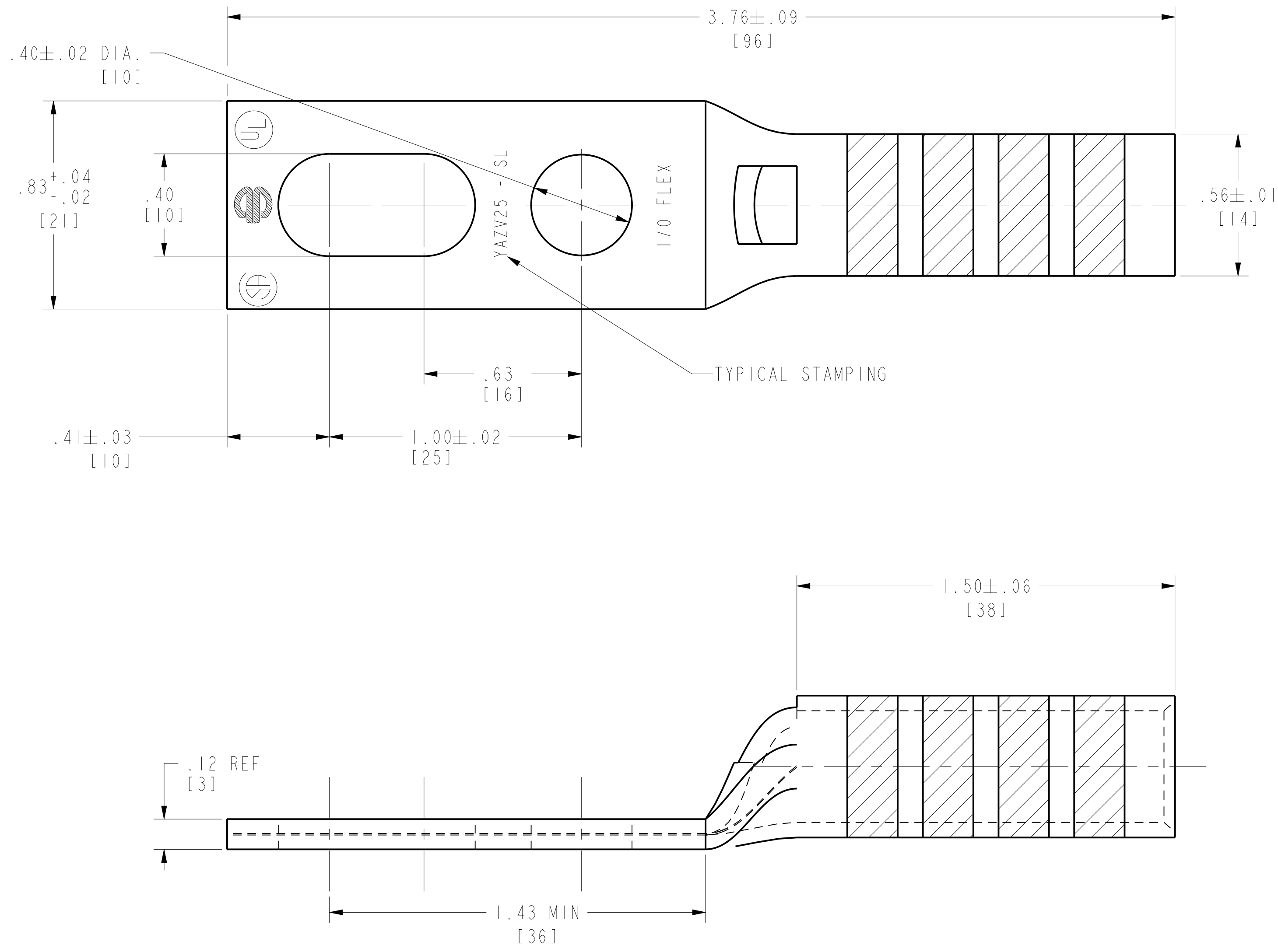

NOTES:

1. MATERIAL: COPPER TUBING.
2. FINISH: TIN PLATED.
3. CATALOG # PT6515 ADAPTOR IS REQUIRED TO USE "U" DIES IN Y45 SERIES TOOLS.
4. CATALOG # PUADP-1 ADAPTOR IS REQUIRED TO USE "U" DIES IN Y46 SERIES TOOLS.
5. DIMENSIONS IN BRACKETS [ ] ARE IN MILLIMETERS ROUNDED OFF TO THE NEAREST MILLIMETER, UNLESS OTHERWISE NOTED, AND ARE FOR REFERENCE ONLY.

TO ORDER BURNDY® PRODUCTS CALL		HYLUG™	
UNITED STATES		ITEM NO: 30014840	
1-800-346-4175 (LONDONDERRY, NH)		CAT. NO: YAZV252TC38FXSL	
CANADA:		DRAWN BY: T.SATHISH 10/14/2011	
1-800-361-6975 (QUEBEC)		CHECKER: K.BOUTIN 04/02/2014	
1-800-387-6487 (ALL OTHER PROVINCES)		DSN APPVL: K.BOUTIN 04/02/2014	
FOR PRODUCT INFO: <a href="http://www.burndy.com">http://www.burndy.com</a>		MFG APPVL: -- --	
		QA APPVL: C.KOWCALCZYK 04/02/2014	
		MKT APPVL: J.SYLVIA 04/01/2014	
		SCALE: 3:1	
		PROD FAM: CM&R COMPRESSION	
		DRAWING NO	
		PROJECT #: --	
		SIZE	
		30020854	
		DOCUMENT TYPE: Sales	
		SHEET 1 OF 1	
		REL LEVEL: Released	
		REV	
		B	

REV: PEO200