

DRAWING NO.  
30023850

REV	DATE	DESCRIPTION	ECO	BY	C'H'K.
A	04/18/2012 00:00:00 AM	CREATE SALES DWG FOR KAZUG7	27168	MB	MA

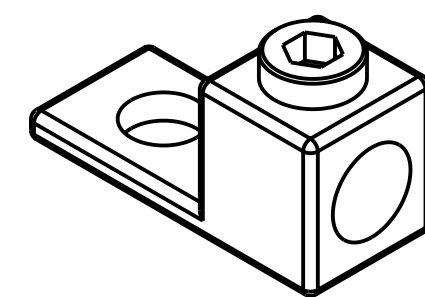
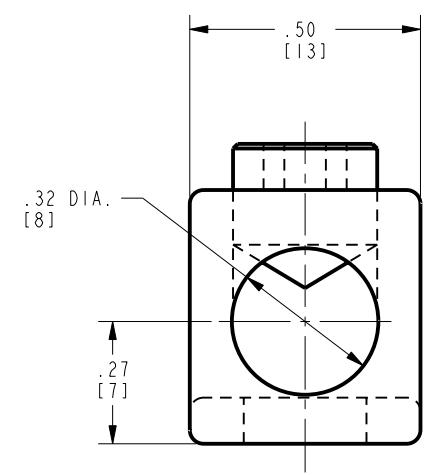
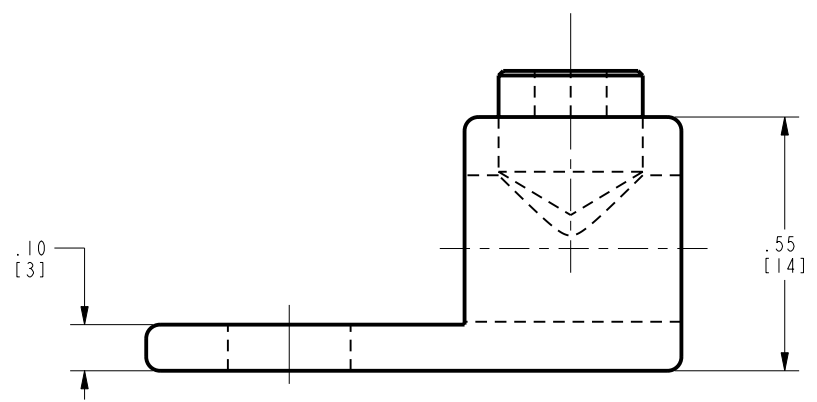
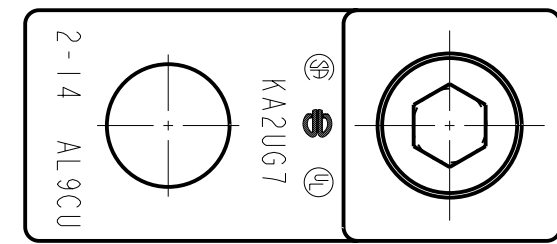
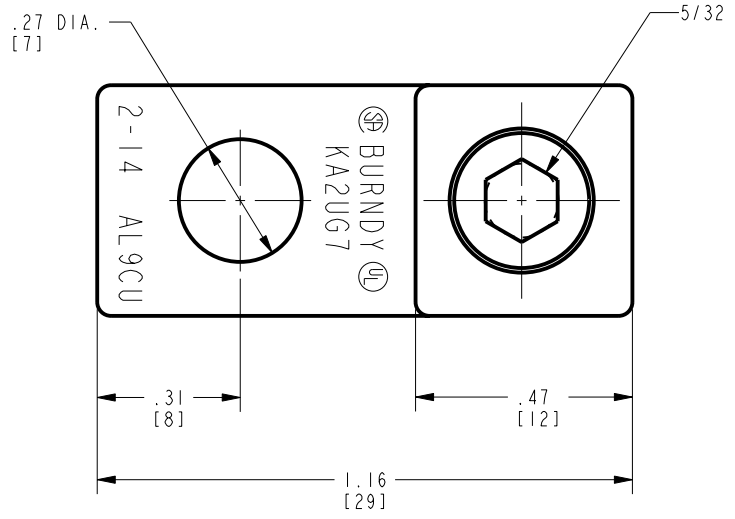

NOTES:

1. MATERIAL-BODY: ALUMINUM  
SCREW: STEEL
2. FINISH-BODY: TIN PLATED  
SCREW: ZINC PLATED
3. DIMENSIONS IN BRACKETS [ ] ARE IN MILLIMETERS ROUNDED OFF TO THE NEAREST MILLIMETER, UNLESS OTHERWISE NOTED, AND ARE FOR REFERENCE ONLY.
4. CONNECTOR IS UL LISTED AND CSA CERTIFIED.

TO ORDER BURNDY® PRODUCTS CALL  
 UNITED STATES:  
 1-800-346-4175 (LONDONDERRY, NH)  
 CANADA:  
 1-800-361-6975 (QUEBEC)  
 1-800-387-6487 (ALL OTHER PROVINCES)  
 FOR PRODUCT INFO: <http://www.burndy.com>

UNIVERSAL TERMINAL			
ITEM NO: 30021489			
CAT. NO: KAZUG7			
DRAWN BY: M.TAMARAIRANI 01/13/12		CHECKER: AYYAPPAN 01/13/12	
DSN APPVL: --		MFG APPVL: --	
QA APPVL: --		MKT APPVL: --	
PROD. FAM: CM&R_Mechanical		SCALE: 4:1	
PROJECT #: --		DRAWING NO: 30023850	
DOCUMENT TYPE: Sales		REV: A	
REL LEVEL: Released		SHEET 1 OF 1	

REV: PE0200