

REVISION	DATE		PART No. SDB-316082-E (SERIES)		
ADDED HOLE OPTION TO TABLE & ADDED ITEM 8	9-9-16		TITLE		
ADDED ITEM 9	12-6-17	DATE 1-20-12	SCALE 1/1	CRIMP TYPE DRAW LEAD TERMINAL	
ERROR, ITEM 8 "L" WAS 4.00 [101.6]	12-22-17	REF.			

NOTES: 1. DIMENSIONS ARE IN INCHES [MILLIMETERS]
2. MATERIAL - COPPER

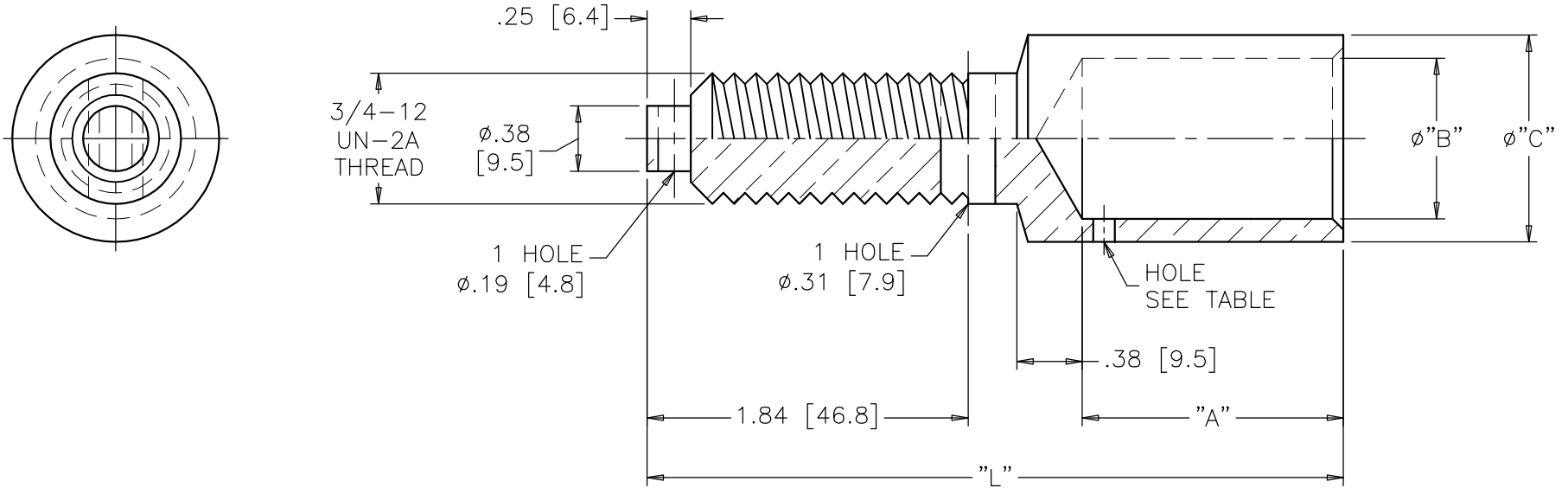

***MUST VERIFY DRAW LEAD WILL PASS THROUGH ENTIRE STUD**

9	4.75 [120.6]	1.50 [38.1]	.650 [16.51]	.810 [20.57]	YES	---	---
8	4.75 [120.6]	1.50 [38.1]	.922 [23.42]	1.188 [30.18]	NO	400 MCM	---
7	4.75 [120.6]	1.50 [38.1]	.828 [21.03]	1.000 [25.40]	YES	350 MCM	350
6	4.75 [120.6]	1.69 [42.9]	.703 [17.86]	.825 [20.96]	YES	250 MCM	---
5	4.50 [114.3]	1.50 [38.1]	.797 [20.24]	1.000 [25.40]	YES	300 MCM	350
4	4.75 [120.6]	1.50 [38.1]	1.000 [25.40]	1.230 [31.24]	YES	-----	---
3	4.75 [120.6]	1.50 [38.1]	.922 [23.42]	1.188 [30.18]	YES	400 MCM	500
2	4.00 [101.6]	1.50 [38.1]	1.000 [25.40]	1.230 [31.24]	YES	-----	---
1	4.00 [101.6]	1.50 [38.1]	.922 [23.42]	1.188 [30.18]	YES	400 MCM	500
ITEM	"L"	"A"	"B"	"C"	HOLE	CABLE SIZE	CRIMP DIE