

CAT.	SIZE	A	B	C	D	E	F	G	H	J	K	L
3511DC	3/8"	1.55 [39.4]	1.28 [32.5]	1.28 [32.5]	1.37 [34.8]	0.61 [15.5]	1.16 [29.5]	0.78 [19.8]	0.59 [15]	0.47 [11.9]	1/2" - 14 NPT	1 3/16" - 18 UNEF
3512DC	1/2"	1.49 [37.8]	1.28 [32.5]	1.29 [32.8]	1.38 [35.1]	0.61 [15.5]	1.07 [27.2]	0.8 [20.3]	0.58 [14.7]	0.48 [12.2]	1/2" - 14 NPT	1 3/16" - 18 UNEF
3513DC	3/4"	1.52 [38.6]	1.48 [37.6]	1.58 [40.1]	1.69 [42.9]	0.82 [20.8]	1.05 [26.7]	0.81 [20.6]	0.81 [20.6]	0.52 [13.2]	3/4" - 14 NPT	1 7/16" - 18UNEF
3514DC	1"	1.95 [49.5]	1.75 [44.5]	1.84 [46.7]	1.94 [49.3]	1 [25.4]	1.36 [34.5]	1.09 [27.7]	0.7 [17.8]	0.65 [16.5]	1" - 11-1/2 NPT	1" - 11/16 UNEF
3515DC	1-1/4"	1.95 [49.5]	2.23 [56.6]	2.27 [57.7]	2.42 [61.5]	1.36 [34.5]	1.5 [38.1]	1.09 [27.7]	0.85 [21.6]	0.65 [16.5]	1 1/4" - 11- 1/2 NPT	2 1/8" - 16 UNEF
3516DC	1-1/2"	2.05 [52.1]	2.48 [63]	2.48 [63]	2.64 [67.1]	1.6 [40.6]	1.45 [36.8]	1.21 [30.7]	0.85 [21.6]	0.71 [18]	1 1/2" - 11- 1/2 NPT	2 3/8" - 16 UNEF
3518DC	2"	2.04 [51.8]	2.9 [73.7]	3.01 [76.5]	3.25 [82.6]	2.07 [52.6]	1.48 [37.6]	0.13 [3.3]	0.84 [21.3]	0.64 [16.3]	2" - 11-1/2 NPT	2 1/2" - 11- 1/2 UNEF
3520DC	2-1/2"	3.43 [87.1]	3.58 [90.9]	3.78 [96]	4.13 [104.9]	2.52 [64]	2.02 [51.3]	2.12 [53.9]	1.24 [31.5]	0.96 [24.4]	2 1/2" - 8 NPT	3 1/2" - 14 UNS
3522DC	3"	3.43 [87.1]	4.21 [106.9]	4.35 [110.5]	4.9 [124.5]	3.15 [80]	2.2 [55.9]	2.13 [54.1]	1.2 [30.5]	0.98 [24.9]	3" - 8 NPT	4" - 14 UNS
3524DC	3-1/2"	4.08 [103.6]	4.77 [121.2]	4.85 [123.2]	5.49 [139.4]	3.6 [91.4]	2.39 [60.7]	2.57 [65.3]	1.22 [31]	1 [25.4]	3 1/2" - 8 NPT	4 1/2" - 14 UNS
3526DC	4"	4.05 [102.9]	5.17 [131.3]	5.25 [133.4]	5.94 [150.9]	4.1 [104.1]	2.35 [59.7]	2.55 [64.8]	1.22 [31]	1.18 [30]	4" - 8 NPT	5" - 14 UNS

TIGHTENING TORQUE			
TRADE SIZE OF FITTING	METRIC DESIGNATOR	TIGHTENING TORQUE	
		N-m	(lbf-in)
1/4a	10	19.8	175
3/8	12	22.6b	200
1/2	16	33.9	300
3/4	21	56.5	500
1	27	79.1	700
1-1/4	35	113	1000
1-1/2	41	136	1200
2	53	181	1600
2-1/2	63	181	1600
3	78	181	1600
3-1/2	91	181	1600
4	103	181	1600

a APPLIES TO FLEXIBLE CORD FITTINGS ONLY

b A 3/8 (12) TRADE-SIZE FITTING FOR USE WITH LIQUID-TIGHT FLEXIBLE METAL CONDUIT SHALL BE TIGHTENED WITH A TORQUE OF 26.5 N-M (235 LBF-IN).

LIST OF PARTS		
DESCRIPTION	MATERIAL	FINISH
BODY	ZINC ALLOY	BURNISHED
NUT	ZINC ALLOY	BURNISHED
LOCK NUT	ZINC ALLOY	BURNISHED
FERRULE	ZINC ALLOY	BURNISHED
SEALING RING	POLYPROPYLENE	PURPLE
GLAND	POLYPROPYLENE	PURPLE
INSULATOR	POLYCARBONATE	PURPLE

NOTES:

- ALL DIMENSIONS ARE IN INCHES AND [MILLIMETERS].
- LOCKNUT SHALL BE HAND-TIGHTENED AND THEN FURTHER TIGHTENED 1/4 TURN WITH A HAMMER AND A FLAT BLADED SCREWDRIVER OR BY AN EQUIVALENT METHOD.
- cULus LISTED.

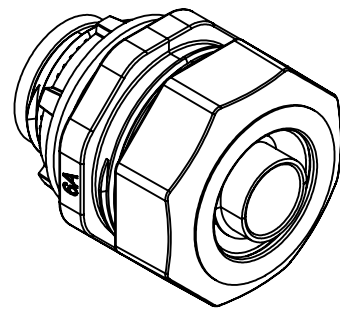

**ISOMETRIC VIEW
SCALE 1 : 1**

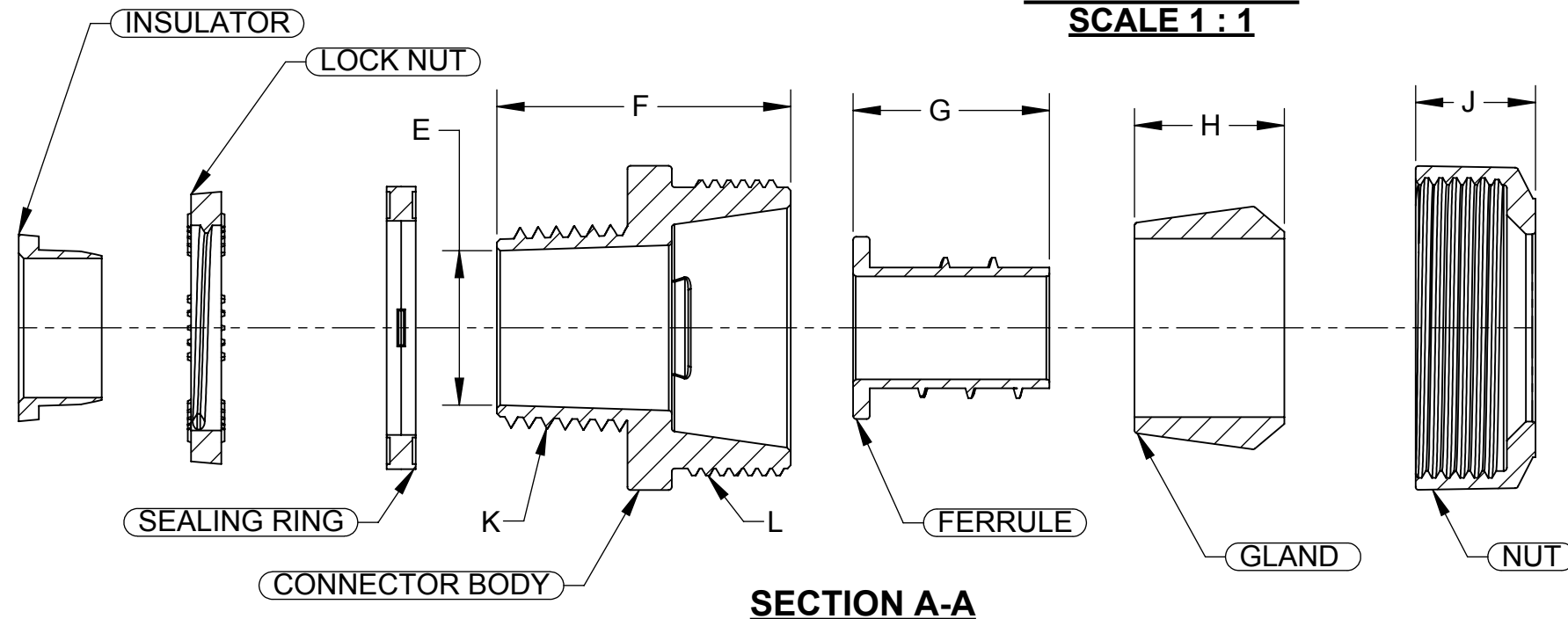
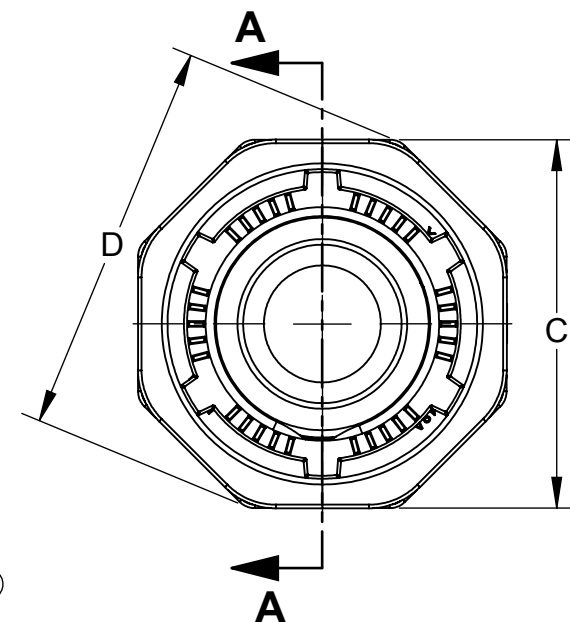
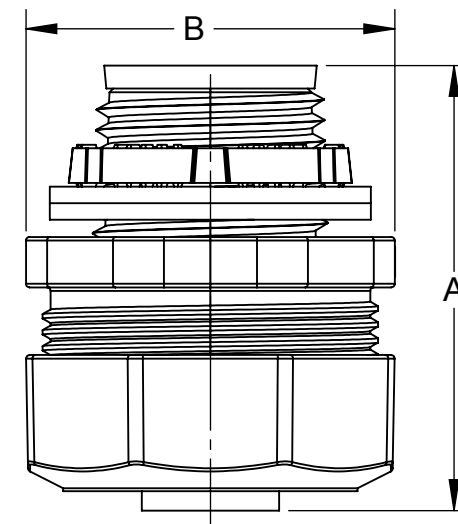

INITIAL RELEASE	F.P.	
REVISION DESCRIPTION	APP	DATE

THE DESIGN AND DIMENSIONS OF THE PRODUCT SHOWN ON THIS DRAWING ARE SUBJECT TO CHANGE WITHOUT NOTICE

TITLE: **ZINC DIE-CAST LIQUID TIGHT CONNECTOR-INSULATED CUS**

TOLERANCE UNLESS OTHERWISE SPECIFIED
 .XX DECIMAL ±.015
 .XXX DECIMAL ±.005
 ANGLE ±2°

RACO
 South Bend, Indiana

DRAWN BY: S.K	SCALE: 3:2
APP. BY: S.J.	
DATE: 05/03/2017	