

NOTES:

- | | | |
|---|-------------------------------|--------------------|
| 1 | CREEPAGE DISTANCE: | 12.78" / 325mm |
| 2 | ARC DISTANCE: | 6.98" / 177mm |
| 3 | INSULATION LEVEL: | 15/50/110kV |
| 4 | NOMINAL CURRENT: | 1200A |
| 5 | NOMINAL VOLTAGE: | 15kV |
| 6 | APPLICATION STANDARD: | IEEE C57.19.01 |
| 7 | WITHSTAND VOLTAGE AT 60 sec.: | 50kV |
| 8 | WEIGHT: | - 64 lbs / 29.1 Kg |

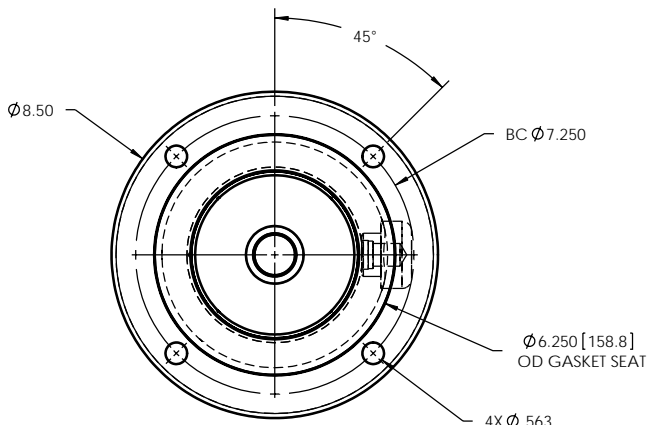
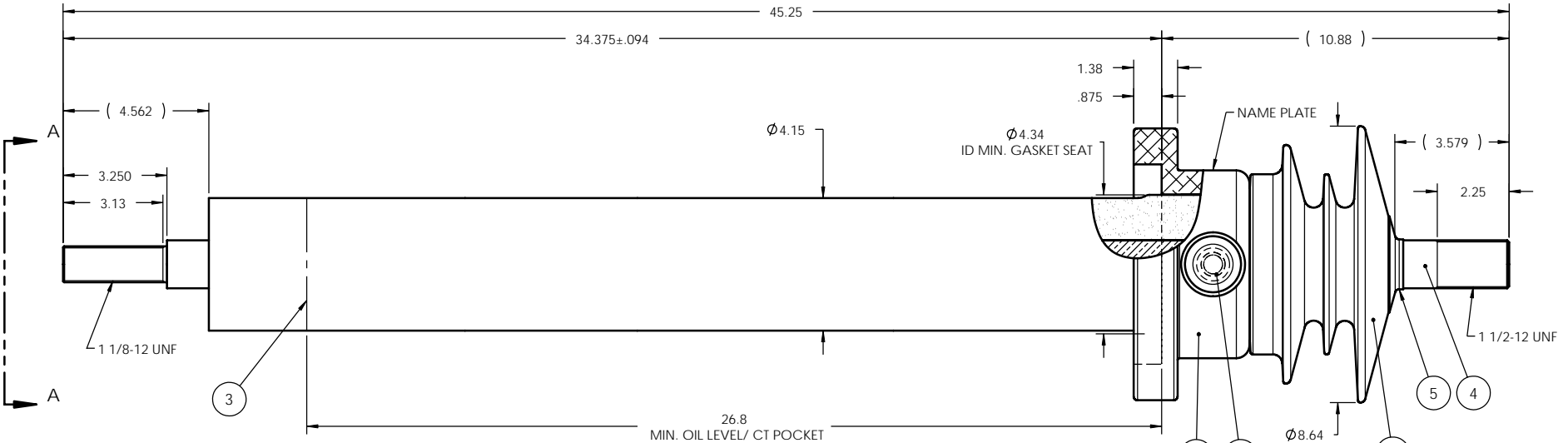

VIEW A-A

ITEM NO.	QTY	DRAWING NO.	PART NO.	DESCRIPTION	NOTE / MAT'L
6	1	S-1001-2022		CAPACITANCE TAP ASSEMBLY	ALUMINUM
5	1	S-1001-0007		CAP	COPPER
4	1	S-5197-4811		ROD ASSEMBLY	COPPER
3	1	S-5197-4810		SHIELD ASSEMBLY	COPPER
2	1	S-5197-4809		FLANGE	ALUMINUM
1	1			CASTING, CYCLOALIPHATIC RESIN	EC-APG-02

PARTS LIST

GENERAL TOLERANCES (UNLESS OTHERWISE SPECIFIED) X. ±0.125 .X ±0.094 .XX ±0.063 .XXX ±0.010 ANGLES ±0.1° RADIUS ±0.031		REPLACE: <h2 style="text-align: center;">GE 5B819</h2>			
REMOVE BURRS AND BREAK SHARP EDGES DIMENSIONS ARE IN INCHES (UNLESS OTHERWISE SPECIFIED)		DRAWN BY: I. Léveillé DATE: 2008/04/24		TITLE: <h3 style="text-align: center;">BUSHING 15kV, 1200A MODEL: 110-012-T-401-00</h3>	
PROJECTING:		CHECK BY:		PROJECT NO.:	
PROJECT MANAGER:		SCALE: 1:5		DRAWING NO.: S-5197-4808 REVISION: NR	
GENERATED BY: SolidWorks 2007		SHEET: 1 of 1		PROJECT MANAGER:	

This drawing is the proprietary property of Electro Composites inc., not part of the public domain, and is issued with the express understanding and agreement that it is not to be reproduced or copied in whole or in part or issued for furnishing information to others, or used directly or indirectly, in any way detrimental to the interest of Electro Composites inc. and is to be returned upon request by Electro Composites inc. All Rights Reserved.