

- NOTES:
- 1 CREEPAGE DISTANCE: 58.8" / 1493mm
 - 2 ARC DISTANCE: 27.1" / 688mm
 - 3 NOMINAL VOLTAGE: 69kV
 - 4 NOMINAL CURRENT: 400A
 - 5 VOLTAGE WITHSTAND, 60 sec.: 160kV
 - 6 BIL : 350kV
 - 7 ROUTINE TEST ACCORDING TO: IEEE C57.19.01
 - 8 MAX. TORQUE APPLIED ON FLANGE BOLTS: 40 lbf·ft / 54.2 N·m
 - 9 WEIGHT: 71 lb / 32.2 Kg

REVISIONS					
ZONE	REV.	DESCRIPTION	DRAWN BY	DATE	APPR.
C3	A	11.75" BECOMES 15.00"	J.N.PILOTTE	2010-03-31	J.V.
B4 E6 D6	B	TUBE ASSEMBLY & CAP CHANGE FROM COPPER TO ALUMINUM. INCREASE THE TOLERANCES ON THE FLANGE OUTSIDE DIAMETER. ADD THE MINIMUM GASKET SEAT DIMENSION.	J. CLICHE	2017-02-20	Y.V.

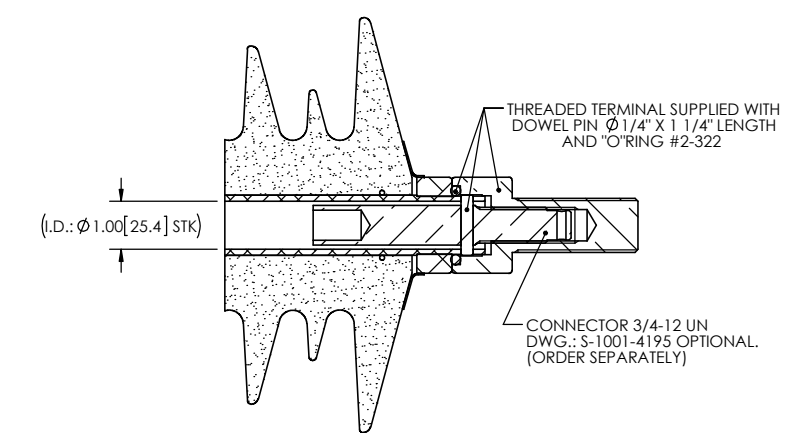
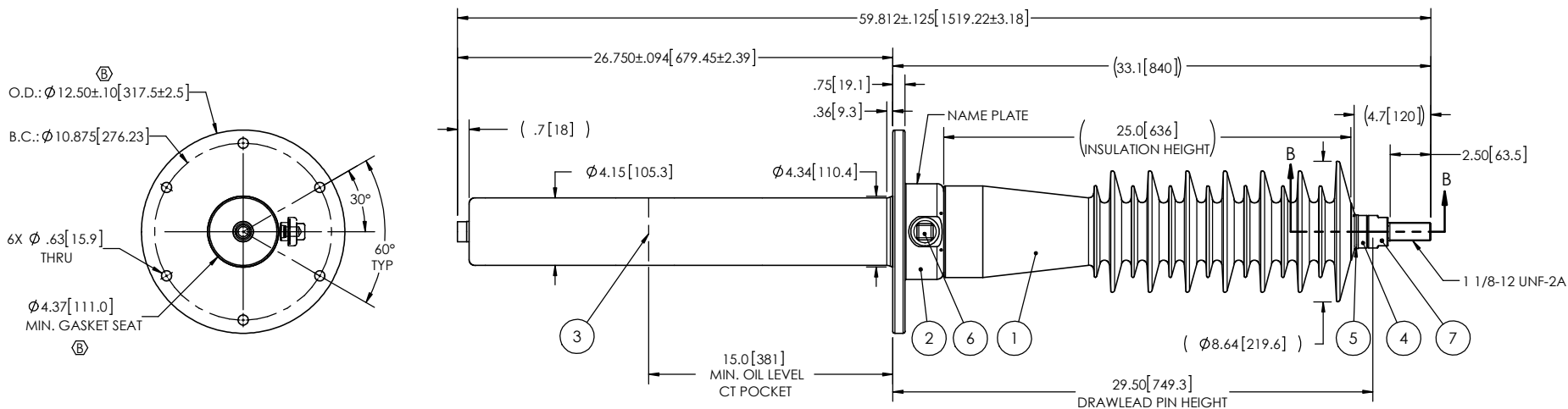

SECTION B-B
SCALE 1 : 4

ITEM NO.	QTY	DRAWING NO.	PART NO.	DESCRIPTION	NOTE / MAT'L
7	1	S-4904-4657-0		THREADED TERMINAL KIT	COPPER
6	1	S-1001-2022		CAPACITANCE TAP ASSEMBLY	ALUMINUM
5	1	S-1344-0162-1		CAP	ALUMINUM
4	1	S-5681-5314		TUBE ASSEMBLY	ALUMINUM
3	1	S-5681-5313		SHIELD ASSEMBLY	COPPER
2	1	S-5681-5312		FLANGE	ALUMINUM
1	1	S-5681-5311	-001	CASTING, CYCLOALIPHATIC RESIN	EC-APG-02

PARTS LIST

GENERAL TOLERANCES
(UNLESS OTHERWISE SPECIFIED)

X. ±0.125
.X ±0.094
.XX ±0.063
.XXX ±0.031
ANGLES ±0.25°
RADIUS ±0.031

REMOVE BURRS AND
BREAK SHARP EDGES

DIMENSIONS ARE IN
INCHES
(UNLESS OTHERWISE SPECIFIED)

Electro Composites™
solid HV bushings solution

TITLE: SDC® BUSHING 69kV, 400A
MODEL: 350-004-T-466-00

DRAWN BY: J.N.PILOTTE	DATE: 2009/03/23	FORMAT: A	CAGE CODE	DRAWING NO.: S-5681-5311	REVISION: B
CHECK BY:		PROJECT ENG.:		GENERATED BY: SolidWorks 2013	SHEET: 1 of 1
PROJECT MGR.:		SCALE: 1:8			

This drawing is the proprietary property of Electro Composites (2008) ULC, not part of the public domain, and is issued with the express understanding and agreement that it is not to be reproduced or copied in whole or in part or issued for furnishing information to others, or used directly or indirectly, in any way detrimental to the interest of Electro Composites (2008) ULC and is to be returned upon request by Electro Composites (2008) ULC. All Rights Reserved.