

REV	DATE	DESCRIPTION	ECO	BY	C'H'K.
E	09/06/2013	UPDATED MODEL AND LOGO DETAILS AS PER MARKUP	33171	VSK	MK

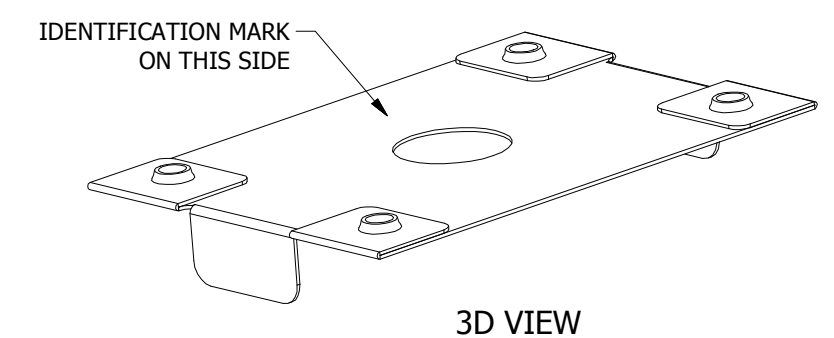
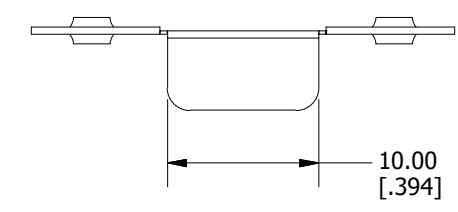
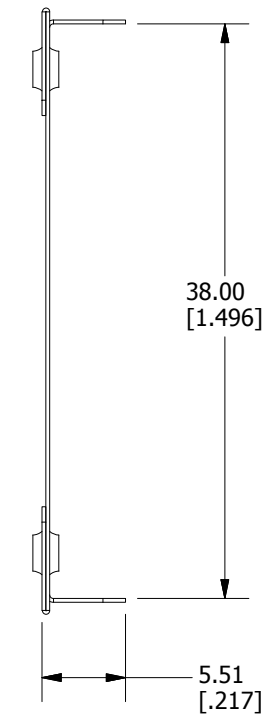
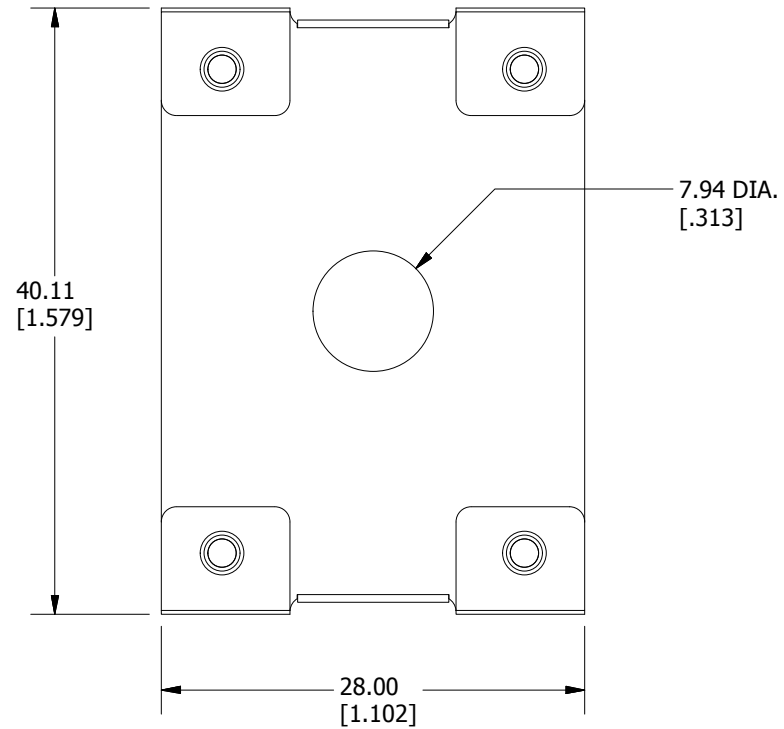
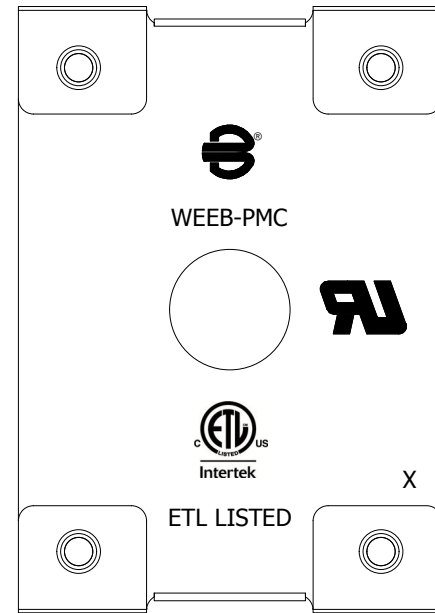

**NOTES:**

1. MATERIAL: 304 STAINLESS STEEL.
2. DIMENSIONS IN BRACKETS [ ] ARE IN INCHES ROUNDED OFF TO THE NEAREST TENTH, UNLESS OTHERWISE SPECIFIED AND ARE FOR REFERENCE ONLY.

TO ORDER BURNDY PRODUCTS CALL		EQUIPMENT BOND	
UNITED STATES 1-800-346-4175 (LONDONDERRY, NH)		ITEM NO: 30020092	
CANADA: 1-800-361-6975 (QUEBEC) 1-800-387-6487 (ALL OTHER PROVINCES)		CAT. NO: WEEB-PMC	
FOR PRODUCT INFO: <a href="http://www.burndy.com">http://www.burndy.com</a>		DRAWN BY: S.KANNAN	9/6/2013
		CHECKER: P.KOVALOV	9/13/2013
		DSN APRVL: T.OLENICK	9/17/2013
		MFG APRVL: M STEVENS	9/10/2013
		QA APRVL: C.KOWALCZYK	9/16/2013
		MKT APRVL: S PARSONS	9/12/2013
PROJ #:	SIZE	DRAWING NO	REV
50000193	B	50000193	E
REL LEVEL: Released		SHEET 1 OF 1	