

REV.	DATE	DESCRIPTION	ECO	BY	C'H'K.
A	09/28/2012 00:00:00 AM	NEW SALES DRAWING RELEASE	27544	KS	JG

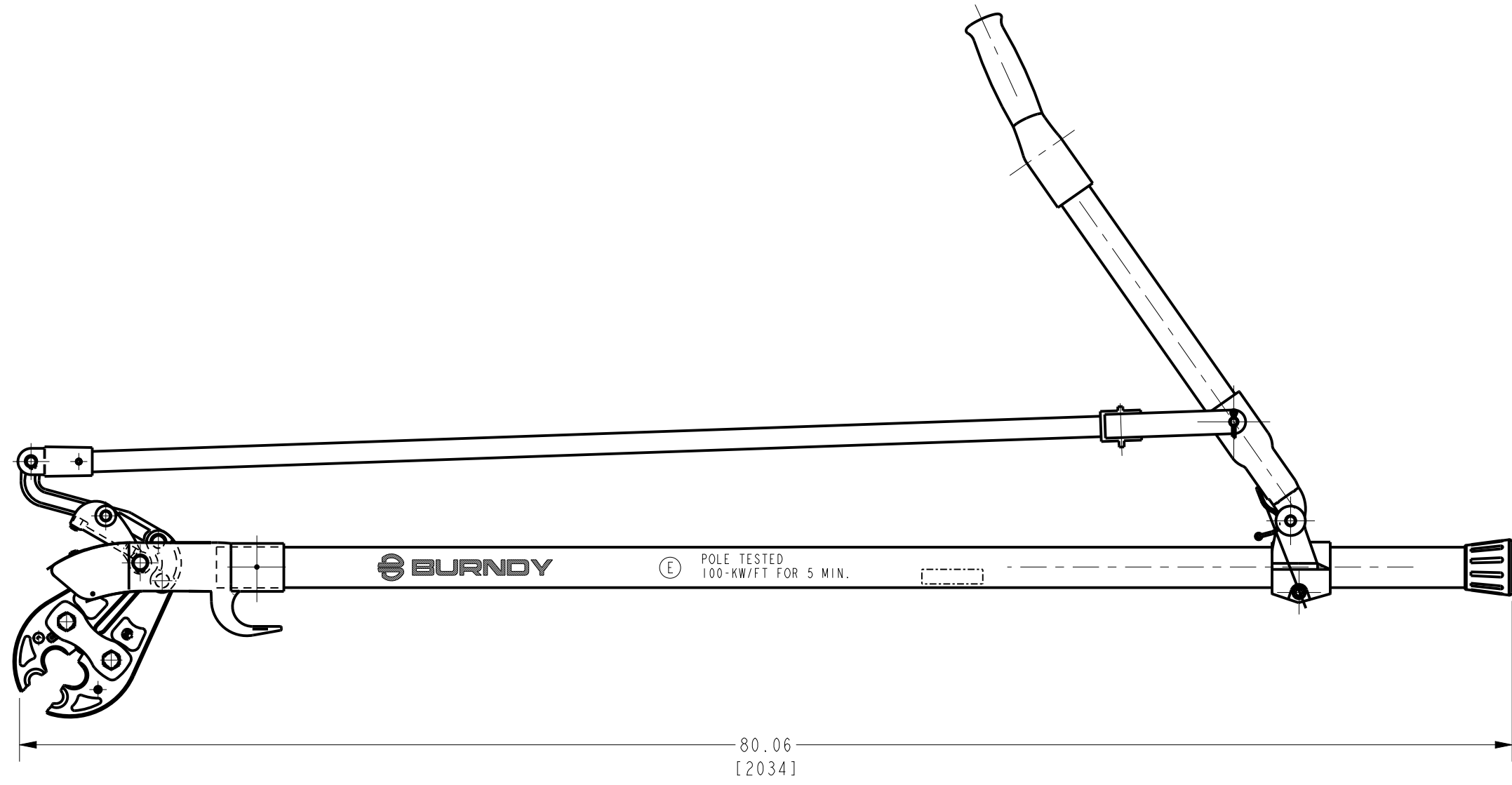

NOTE:

- DIMENSIONS IN BRACKETS [] ARE IN MILLIMETERS ROUNDED OFF TO THE NEAREST MILLIMETER, UNLESS OTHERWISE NOTED, AND ARE FOR REFERENCE ONLY.
- MATERIAL:
FORGED STEEL CRIMPING JAWS
CAST ALUMINUM FRAME AND PIVOT MEMBERS.
FIBER GLASS HOTSTICK AND CONTROL ROD.
- ELECTRICAL TEST:
ALL FIBERGLASS POLES AND CONTROL
ROD TESTED TO 100 KV PER FOOT FOR 5 MIN.

REV: PE0200

TO ORDER BURNDY® PRODUCTS CALL		HOT STICK	
UNITED STATES: 1-800-346-4175 (LONDONDERRY, NH)		ITEM NO: 464635	CAT. NO: MD6HS72
CANADA: 1-800-361-6975 (QUEBEC) 1-800-387-6487 (ALL OTHER PROVINCES)		DRAWN BY: K SHRIDHAR 05/17/2012	CHECKER: --
FOR PRODUCT INFO: http://www.burndy.com		DSN APPVL: --	MFG APPVL: --
		QA APPVL: --	MKT APPVL: --
		PROJ FAM: --	PROJECT #: --
		DOCUMENT TYPE: Sales	REL LEVEL: Released
		SIZE: B	DRAWING NO: 50005192
			REV: A
			SHEET 1 OF 1



SCALE: 1:16