

CATALOG NUMBER	STRANDED COPPER CONDUCTOR ACCOMMODATED			BOLT SIZE	INSTALLATION TOOLING (# OF CRIMPS)										REV	DATE	DESCRIPTION	ECO	BY	CHK.	
					COLOR CODE	DIE INFORMATION		MECHANICAL	HYDRAULIC						DIELESS (# CRIMPS)	WIRE STRIP LENGTH	B	07/28/2015	BARREL VIEW CHANGED FROM BLUE TO WHITE	41094	SPR
	CODE (AWG)	NAVY	METRIC SIZE (CLASS 2)			DIE INDEX	TYPE	MD6-R2 MD7-34R	Y34A Y34B Y34BH	Y35, Y39, Y750, PAT750	Y46, PAT46	Y45	Y48B	Y60BHU							
YA30LN	300 Kcmil	300	150 mm ² STR [16.2] 185 mm ² STR [15.9]	1/2" [M12]	WHITE	17 (OR) 298	WHITE DIE SET NEST INDENTOR	W30RT (2) ---- ----	A28AR (1) B30D (1) A30D (1) Y34PR	U30RT (2) U28ART (2) U30D-1 (1) Y34PR	U30RT (2) U28ART (2) U30D-1 (1) Y34PR	U30RT (2) U28ART (2) U30D-1 (1) Y34PR	C30R (1) C28AR (1) C30D (1) Y48PR	L30RT (1) ---- ----	HYDRAULIC: Y644 (1) Y81KFT (2) Y4PC834 (2)	1"					

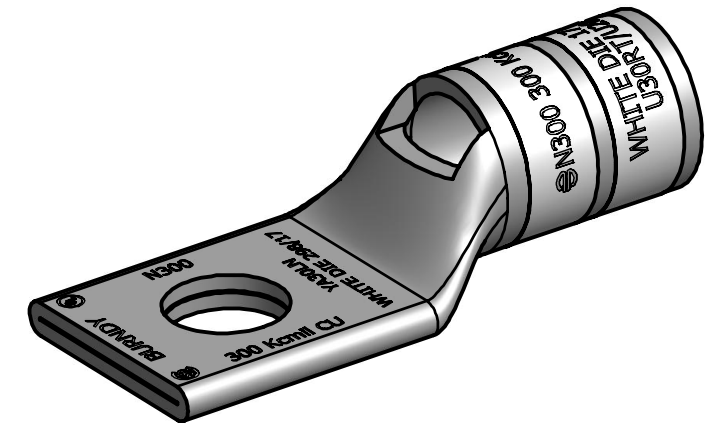
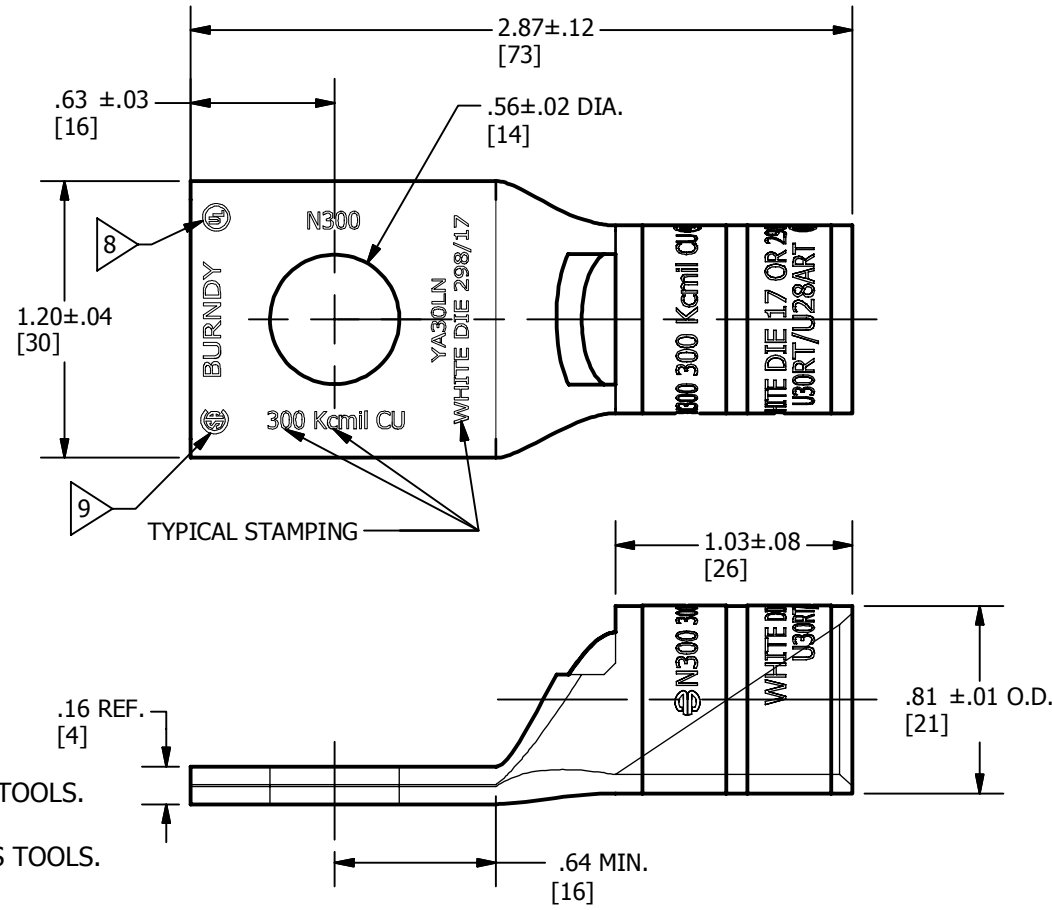

NOTES:

1. MATERIAL: COPPER TUBING.
2. FINISH: TIN PLATED.
3. CATALOG # PT6515 ADAPTOR IS REQUIRED TO USE "U" DIES IN Y45 SERIES TOOLS.
4. CATALOG # PUADP-1 ADAPTOR IS REQUIRED TO USE "U" DIES IN Y46 SERIES TOOLS.
5. Y35P3 INDENTOR ADAPTOR REQUIRED FOR Y34PR INDENTOR.
6. DIMENSIONS IN BRACKETS [] ARE IN MILLIMETERS ROUNDED OFF TO THE NEAREST MILLIMETER, UNLESS OTHERWISE SPECIFIED AND ARE FOR REFERENCE ONLY.
7. FOR USE BY CUSTOMERS THAT HAVE THIS HYPRESS™. NO NEW Y34A HYPRESS™ TOOLS ARE BEING PROCESSED. Y34A USES A--D TYPE NEST DIES.
8. CONNECTOR IS UL LISTED.
9. CONNECTOR IS CSA CERTIFIED.
10. "X", "W-RT", "W-VT", "U" & "L" DIE SETS ARE COLOR CODED. "A", "B", AND "C" DIES ARE NOT COLOR CODED. NESTS AND INDENTOR TYPE ARE NOT COLOR CODED.
11. 185 mm² STR NOT UL/CSA LISTED.

TO ORDER BURNDY PRODUCTS CALL		HYLUG™	
UNITED STATES		ITEM NO: 50001460	
1-800-346-4175 (LONDONDERRY, NH)		CAT. NO: YA30LN	
CANADA:		DRAWN BY: B.SURESH BABU 08/22/2012	
1-800-361-6975 (QUEBEC)		CHECKER: J.MICHAUD 08/30/2012	
1-800-387-6487 (ALL OTHER PROVINCES)		DSN APRVL: J.MICHAUD 08/30/2012	
FOR PRODUCT INFO: http://www.burndy.com		MFG APRVL: M.SMITH 08/31/2012	
		QA APRVL: T.WATTS 08/31/2012	
		MKT APRVL: --	
PROD FAM: CM&R COMPRESSION	DRAWING NO	REV	
PROJECT #: --	SIZE	50007570	B
DOCUMENT TYPE: SALES	B	SHEET 1 OF 1	
REL LEVEL: Released			