

CATALOG NO.	CONDUCTOR ACSR-ALUM-ACAR ALL STRANDING	INSTALLATION DATA OVERLAP CRIMPS						
		BURNDY® HYPRESS™ & DIE SET		ALCOA DIE SET <sup>2</sup>		T & B DIE SET <sup>3</sup>	ACA DIES	
		TOOL DIE NO.	Y60B	150B	H2H / 100A	T & B 21940 TYPE PRESS	60 TON PRESS	100 TON PRESS
YNA39R4N	556.5 kcmil [282 sq mm] ACSR 600 - 650 kcmil [304.0 - 329.4 sq mm] ALUM 634.9 - 653.1 kcmil [321.7 - 330.9 sq mm] ACAR	722	L722	M722	H722 / MH722	125	6024AH	10024AH

REV	DATE	DESCRIPTION	ECO	BY	CHK.
A	09/26/2012	NEW SALES DRAWING CREATION	28925	AT	DD

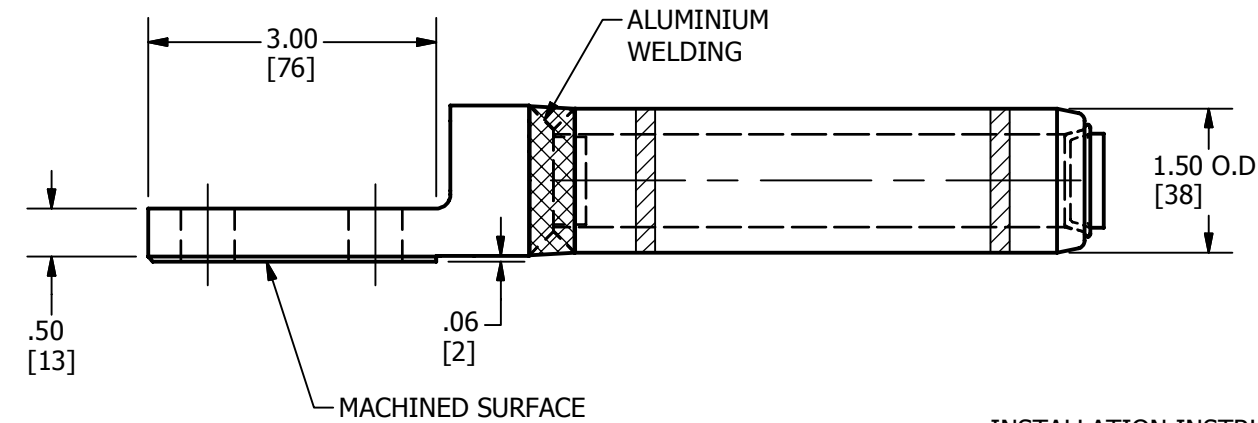
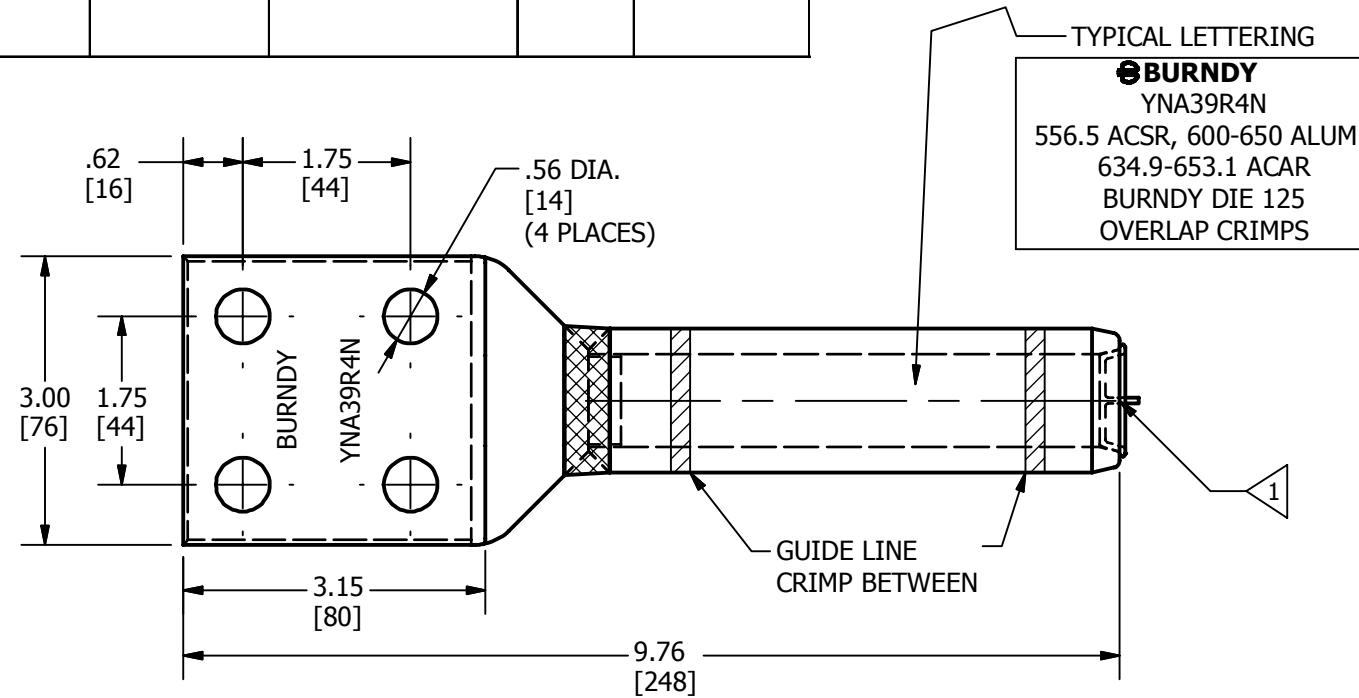

**NOTES:**

- 1 BARRELS PRE-FILLED WITH PENETROX™ & SEALED.
- 2 THE DIES LISTED ARE MANUFACTURED BY BURNDY® CORP. FOR USE IN ALCOA H2H & 150B PRESSES.
- 3 THE EQUIVALENT T&B DIE INDEXES ARE LISTED FOR YOUR CONVENIENCE.
4. TONGUE COATED WITH AN OXIDE RETARDANT.
5. HYLUG™ VARIATIONS:  
TO SPECIFY HYLUG™ INCLUDING HARDWARE: ADD SUFFIX H  
TO RESPECTIVE CAT.NO EG.YNA39R4NH
6. RECOMMENDED TORQUE:  
1/2" DIA. BOLTS-300 IN-LBS. [34Nm]
7. CONNECTOR IS INDIVIDUALLY PACKAGED & SEALED IN POLYTUBE.
8. DIMENSIONS IN BRACKETS [ ] ARE IN MILLIMETERS ROUNDED OFF TO THE NEAREST MILLIMETER, UNLESS OTHERWISE SPECIFIED AND ARE FOR REFERENCE ONLY.

INSTALLATION INSTRUCTION ON DWG. 30002494

TO ORDER BURNDY® PRODUCTS CALL		HYLUG™ ACSR-ALUM-ACAR <230 KV	
UNITED STATES 1-800-346-4175 (LONDONDERRY, NH)		ITEM NO: 195579	
CANADA: 1-800-361-6975 (QUEBEC) 1-800-387-6487 (ALL OTHER PROVINCES)		CAT. NO: YNA39R4N	
FOR PRODUCT INFO: <a href="http://www.burndy.com">http://www.burndy.com</a>		DRAWN BY: THIRU 26-09-2012	
		CHECKER: P. WALTZ 09-11-2012	
		DSN APRVL: P. WALTZ 09-11-2012	
		MFG APRVL: --	
		QA APRVL: C. ACKERMAN 04-12-2012	
		MKT APRVL: D. HAMILTON 19-11-2012	
		PROD FAM: CM&R	
		DRAWING NO	
		50009455	
		REV	
		A	
		SHEET 1 OF 1	