

REV	DATE	DESCRIPTION	ECO	BY	CHK.
A	10/25/2012	SALES DRAWING CREATION	29185	KK	MA

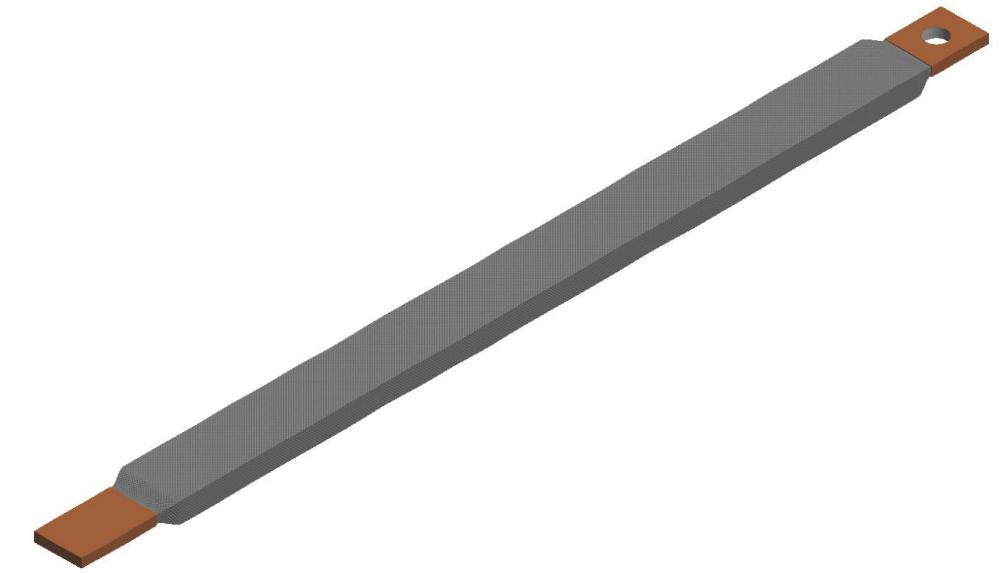
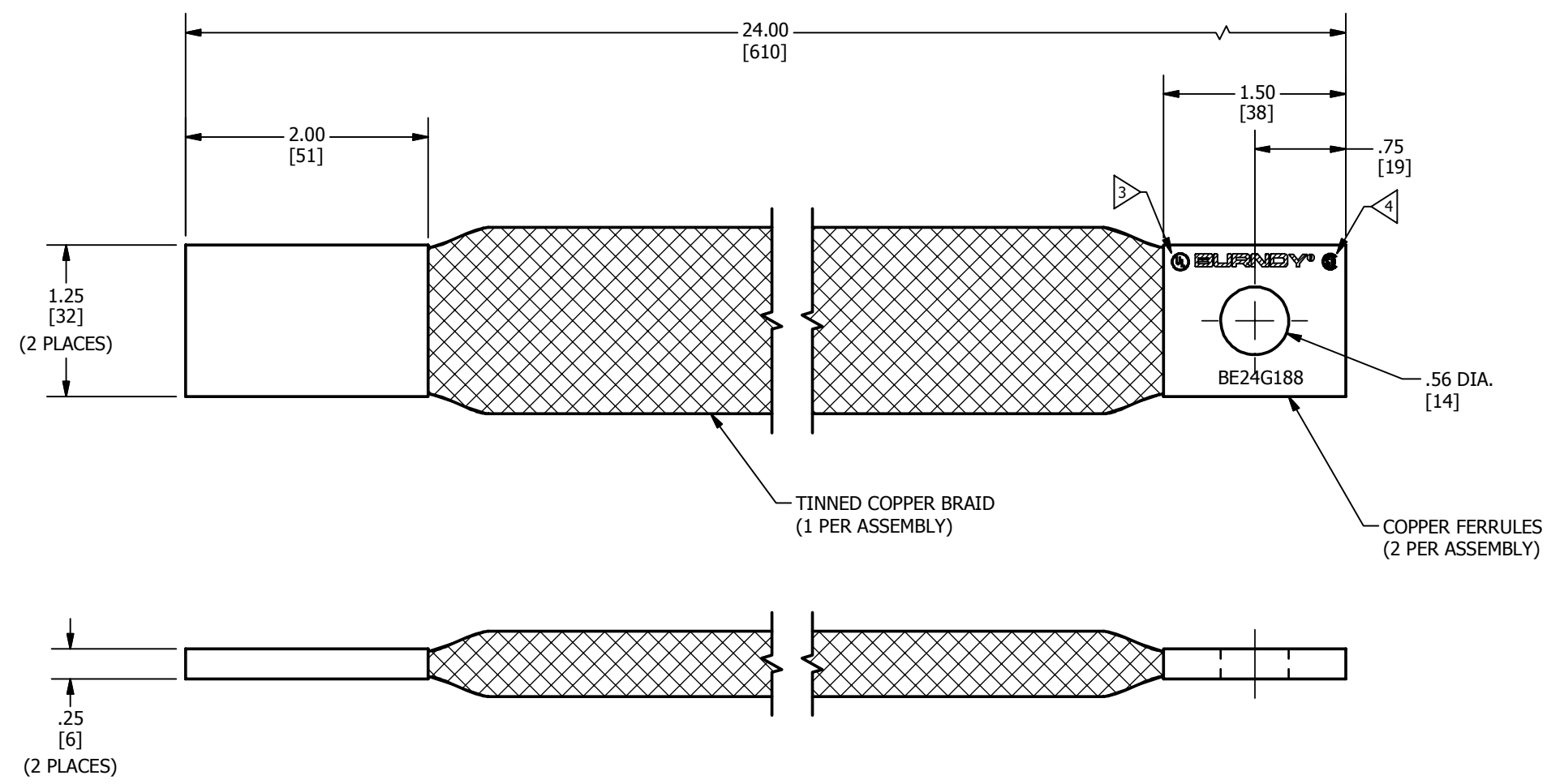

- NOTES:
1. APPROXIMATE AMP RATING: 340A INDOOR, 405A OUTDOOR. THIS RATING MAY VARY WITH AMBIENT CONDITIONS, ORIENTATION OF THE BRAID, AND OTHER SERVICE CONDITIONS.
 2. DIMENSIONS IN BRACKETS [] ARE IN MILLIMETERS ROUNDED OFF TO THE NEAREST MILLIMETER, UNLESS OTHERWISE NOTED, AND ARE FOR REFERENCE ONLY.
 3. BRAID LISTED TO UL 467 GROUNDING & BONDING EQUIPMENT STANDARDS.
 4. BRAID LISTED TO CSA 22.2 NO.41 GROUNDING & BONDING EQUIPMENT STANDARDS.

TO ORDER BURNDY® PRODUCTS CALL		BRAID	
UNITED STATES 1-800-346-4175 (LONDONDERRY, NH)		ITEM NO: 50009644	
CANADA: 1-800-361-6975 (QUEBEC) 1-800-387-6487 (ALL OTHER PROVINCES)		CAT. NO: BE24G188	
FOR PRODUCT INFO: http://www.burndy.com		DRAWN BY: BALAN.T 10/12/2012	
		CHECKER: R.TROY 11/21/2012	
		DSN APRVL: C.RICARDO 11/23/2012	
		MFG APRVL: --	
		QA APRVL: M.JOEL 11/21/2012	
		MKT APRVL: R.KATHLEEN 11/26/2012	
		PROD FAM: MECHANICAL GROUNDING	
		PROJECT #: --	
		SIZE	
		DRAWING NO	
		50009646	
		REV	
		A	
		SHEET 1 OF 1	
		REL LEVEL: Released	