

CATALOG NO.	CONDUCTOR		BOLT SIZE	INSTALLATION TOOLING (# CRIMPS)								DIELESS (# CRIMPS)	WIRE STRIP LENGTH
	CODE (AWG)	NAVY		DIE INDEX	COLOR CODE	MECHANICAL RATCHET		HYDRAULIC					
						MD7-34R MD6	OUR840	Y34A \triangleleft 7	Y750, Y35, Y39	Y46 \triangleleft 4	Y45 \triangleleft 3		
YAZ262TC38E16	2/0 AWG [70mm ² STR]	125	3/8 [M10]	13	BLACK	W26VT W26RT (2)	W26VT W26RT (2)	A26R (2)	U26RT (2)	U26RT (2)	U26RT (2)	MECHANICAL: MY29-11 (1) HYDRAULIC: Y644, Y644M, Y644MBH, Y1000, Y1000BH (1)	1 - 9/16"

REV	DATE	DESCRIPTION	ECO	BY	C'H'K
A	11/5/2012	DRAWING RELEASED	29167	SS	MA

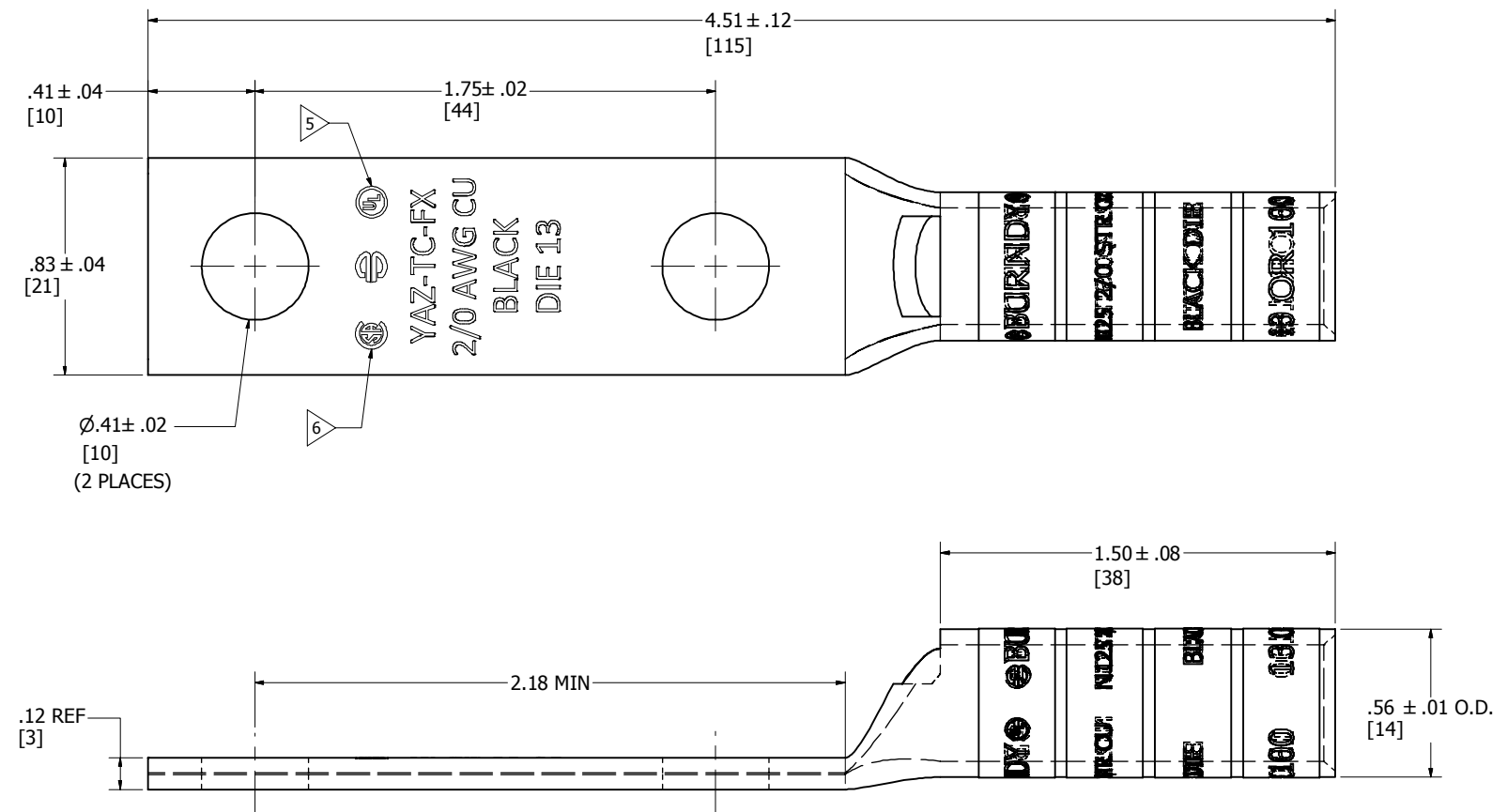

	N125 2/0 STR CU	
	BLACK DIE	
	13 OR 100	
BARREL MARKING		

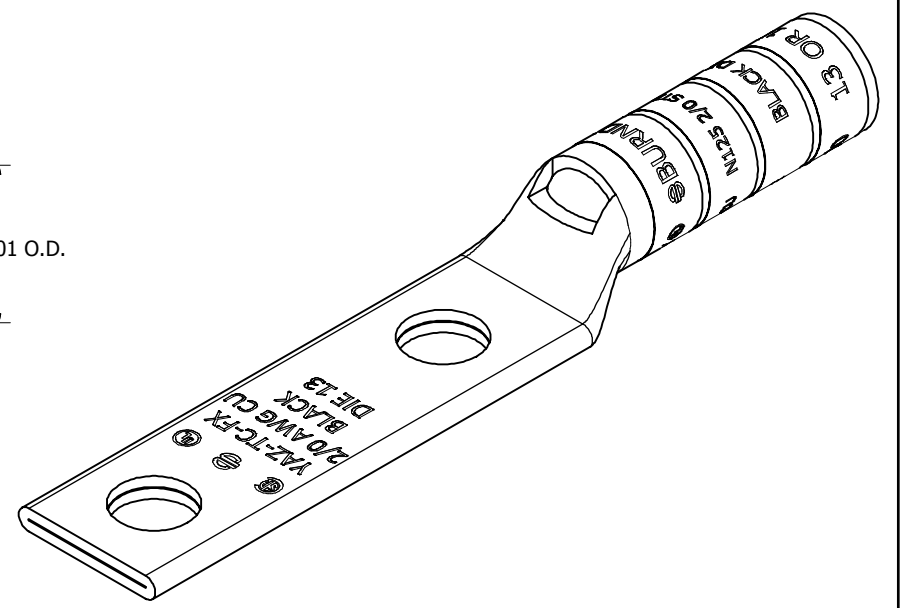

NOTES:

- MATERIAL: COPPER TUBING
- FINISH: TIN PLATED.
- CATALOG # PT6515 ADAPTOR IS REQUIRED TO USE "U" DIES IN Y45 SERIES TOOLS.
- CATALOG # PUADP-1 ADAPTOR IS REQUIRED TO USE "U" DIES IN Y46 SERIES TOOLS.
- CONNECTORS ARE UL LISTED.
- CONNECTORS ARE CSA CERTIFIED.
- FOR USE BY CUSTOMERS THAT HAVE THIS HYPRESS™ NO NEW Y34A HYPRESS™ ARE BEING PROCESSED.
- DIMENSIONS IN BRACKETS [] ARE IN MILLIMETERS ROUNDED OFF TO THE NEAREST MILLIMETER, UNLESS OTHERWISE NOTED, AND ARE FOR REFERENCE ONLY.

TO ORDER BURNDY® PRODUCTS CALL		HYLUG™													
UNITED STATES 1-800-346-4175 (LONDONDERRY, NH)		ITEM NO: 50009727													
CANADA: 1-800-361-6975 (QUEBEC) 1-800-387-6487 (ALL OTHER PROVINCES)		CAT. NO: YAZ262TC38E16													
FOR PRODUCT INFO: http://www.burndy.com		<table border="1"> <tr> <td>DRAWN BY: S.SRIRAM</td> <td>11/5/2012</td> </tr> <tr> <td>CHECKER: J.MICHAUD</td> <td>10/30/2012</td> </tr> <tr> <td>DSN APRVL: J.MICHAUD</td> <td>10/31/2012</td> </tr> <tr> <td>MFG APRVL: M.SMITH</td> <td>11/2/2012</td> </tr> <tr> <td>QA APRVL: T.WATTS</td> <td>10/30/2012</td> </tr> <tr> <td>MKT APRVL: J.SLYVIA</td> <td>10/30/2012</td> </tr> </table>		DRAWN BY: S.SRIRAM	11/5/2012	CHECKER: J.MICHAUD	10/30/2012	DSN APRVL: J.MICHAUD	10/31/2012	MFG APRVL: M.SMITH	11/2/2012	QA APRVL: T.WATTS	10/30/2012	MKT APRVL: J.SLYVIA	10/30/2012
DRAWN BY: S.SRIRAM	11/5/2012														
CHECKER: J.MICHAUD	10/30/2012														
DSN APRVL: J.MICHAUD	10/31/2012														
MFG APRVL: M.SMITH	11/2/2012														
QA APRVL: T.WATTS	10/30/2012														
MKT APRVL: J.SLYVIA	10/30/2012														
		<table border="1"> <tr> <td>PROD FAM: CM&R COMPRESSION</td> <td>DRAWING NO</td> <td>REV</td> </tr> <tr> <td>PROJECT #: --</td> <td>SIZE</td> <td></td> </tr> <tr> <td>DOCUMENT TYPE: SALES</td> <td>50009728</td> <td>A</td> </tr> <tr> <td>REL LEVEL: Released</td> <td>D</td> <td>SHEET 1 OF 1</td> </tr> </table>		PROD FAM: CM&R COMPRESSION	DRAWING NO	REV	PROJECT #: --	SIZE		DOCUMENT TYPE: SALES	50009728	A	REL LEVEL: Released	D	SHEET 1 OF 1
PROD FAM: CM&R COMPRESSION	DRAWING NO	REV													
PROJECT #: --	SIZE														
DOCUMENT TYPE: SALES	50009728	A													
REL LEVEL: Released	D	SHEET 1 OF 1													