

STRANDED COPPER CONDUCTOR ACCOMMODATED			BOLT SIZE	METRIC BOLT SIZE	COLOR CODE	DIE INFORMATION		MECHANICAL RATCHET				HYDRAULIC				DIELESS (# OF CRIMPS)	WIRE STRIP LENGTH	REV	DATE	DESCRIPTION	ECO	BY	CHK.				
CODE (AWG)	NAVY	METRIC SIZE (CLASS 2)				DIE INDEX	TYPE	YIMRTC	OUR840	MD6 MD7	MD6--R2 MD7-34R	Y500CT PAT600	Y34A Y34B Y34BH	Y35, Y39, Y750, PAT750	Y46 PAT46			Y45	Y48B	Y60BHU	A	10/01/2012	NEW SALES DRAWING CREATED	28941	REX	MA	
#2 AWG	60	----	1/2	M12	BROWN	10	BROWN DIE SET	BROWN (4)	X2CRT (2)	W2CRT (2) W2CVT (2)	W2CRT (2) W2CVT (2)	W2CRT (2) W2CVT (2)	X2CRT (2) W2CRT (2) W2CVT (2)	----	U2CRT (2)	U2CRT (2)	U2CRT (2)	----	----	MECHNAICAL: MY29-3 (2), MY29 - 11 (2) MRC - 840 (2) HYDRAULIC: Y644M (1), PAT644M (1) Y81K - SERIES (1) PAT81K - SERIES (1) Y81KFT - SERIES (2) Y4PC834 - SERIES (2)	1- 5/16"						
							NEST							B2CD(1) A2CD(1)	U2CD-1(1)	U2CD-1(1)	U2CD-1(1)										
							INDENTER							Y34PR	Y34PR	Y34PR											

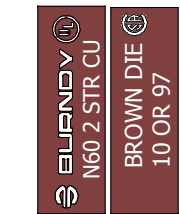

BARREL MARKING

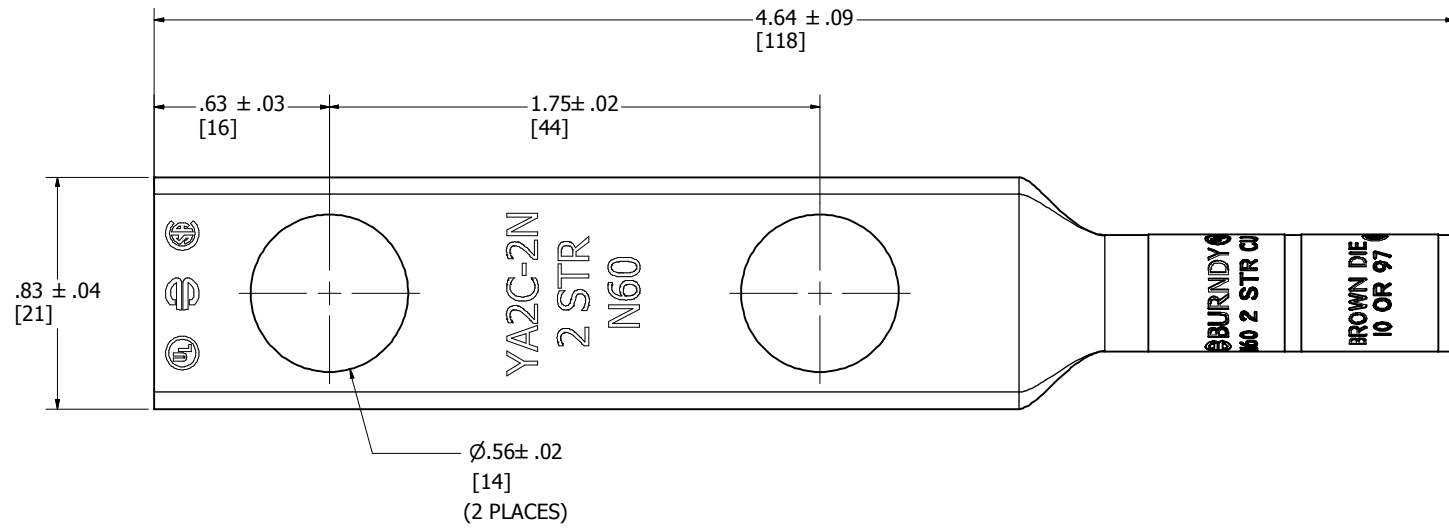
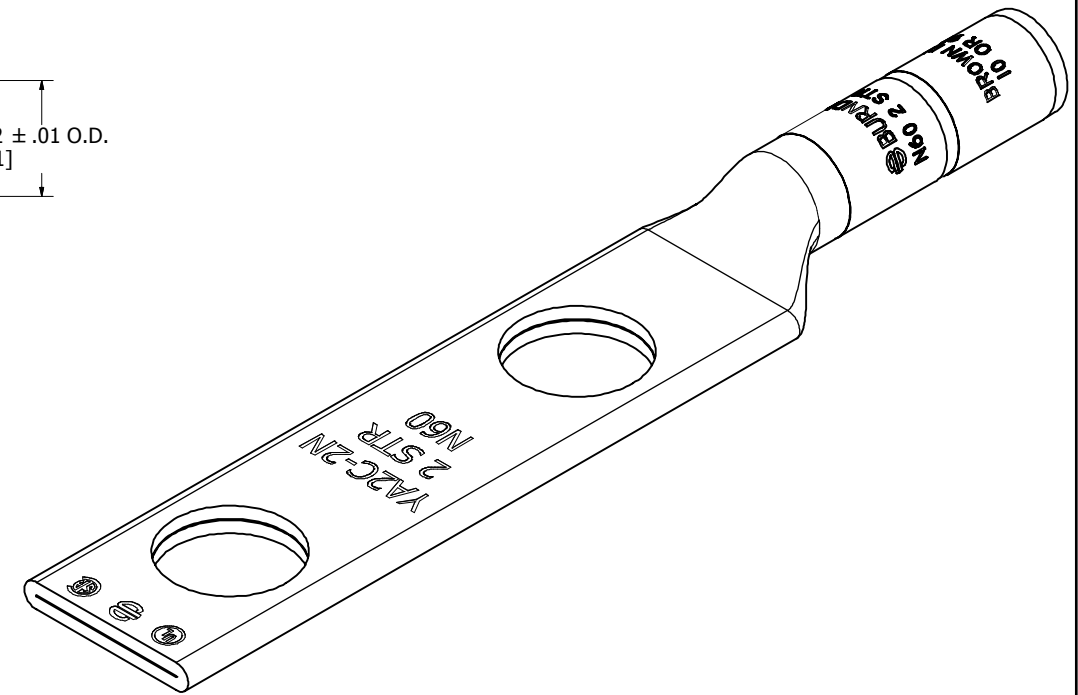
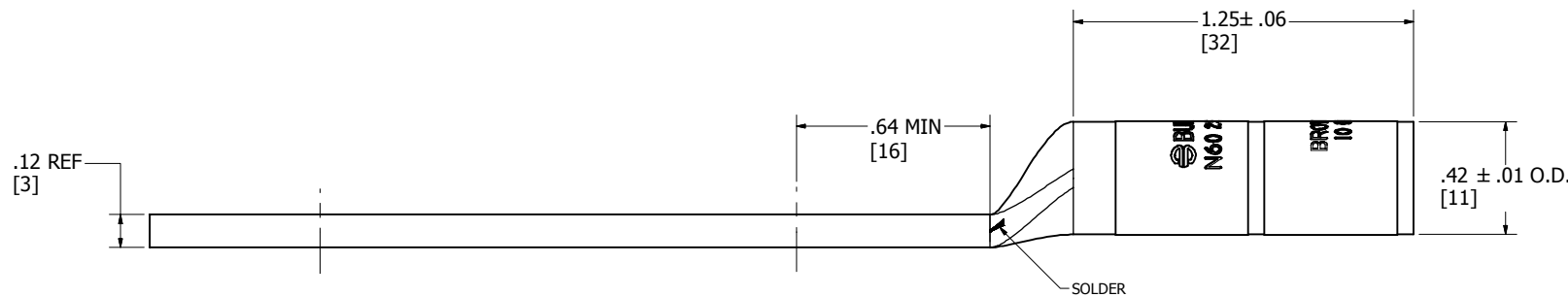

NOTES:

- MATERIAL: COPPER TUBING
- FINISH: TIN PLATED.
- CATALOG # PT6515 ADAPTOR IS REQUIRED TO USE "U" DIES IN Y45 SERIES TOOLS.
- CATALOG # PUADP-1 ADAPTOR IS REQUIRED TO USE "U" DIES IN Y46 SERIES TOOLS.
- Y35P3 INDENTOR ADAPTOR REQUIRED FOR Y34PR INDENTOR.
- PERMANENT DIE IN TOOLING.
- DIMENSIONS IN BRACKETS [] ARE IN MILLIMETERS ROUNDED OFF TO THE NEAREST MILLIMETER, UNLESS OTHERWISE NOTED, AND ARE FOR REFERENCE ONLY.
- FOR USE BY CUSTOMERS THAT HAVE THIS HYPRESS™ NO NEW Y34A HYPRESS™ TOOLS ARE BEING PROCESSED. Y34A USES A--D TYPE NEST DIES.
- UL LISTED AND CSA CERTIFIED WIRE CONNECTOR.
- "X", "W-RT", "W-VT", "U", & "L" DIE SETS ARE COLOR CODED. "A", "B", AND "C" DIES ARE NOT COLOR CODED. NESTS AND INDENTOR TYPE ARE NOT COLOR CODED.

TO ORDER BURNDY® PRODUCTS CALL		HYLUG™													
UNITED STATES 1-800-346-4175 (LONDONDERRY, NH)		ITEM NO: 50218N													
CANADA: 1-800-361-6975 (QUEBEC) 1-800-387-6487 (ALL OTHER PROVINCES)		CAT. NO: YA2C2NDTS													
FOR PRODUCT INFO: http://www.burndy.com		<table border="1"> <tr> <td>DRAWN BY: REX</td> <td>10/1/2012</td> </tr> <tr> <td>CHECKER: J MICHAUD</td> <td>4/13/2013</td> </tr> <tr> <td>DSN APRVL: R ROMAN</td> <td>3/21/2013</td> </tr> <tr> <td>MFG APRVL: M KNAPTON</td> <td>3/18/2013</td> </tr> <tr> <td>QA APRVL: T WATTS</td> <td>3/11/2013</td> </tr> <tr> <td>MKT APRVL: J SYLVIA</td> <td>3/11/2013</td> </tr> </table>		DRAWN BY: REX	10/1/2012	CHECKER: J MICHAUD	4/13/2013	DSN APRVL: R ROMAN	3/21/2013	MFG APRVL: M KNAPTON	3/18/2013	QA APRVL: T WATTS	3/11/2013	MKT APRVL: J SYLVIA	3/11/2013
DRAWN BY: REX	10/1/2012														
CHECKER: J MICHAUD	4/13/2013														
DSN APRVL: R ROMAN	3/21/2013														
MFG APRVL: M KNAPTON	3/18/2013														
QA APRVL: T WATTS	3/11/2013														
MKT APRVL: J SYLVIA	3/11/2013														
PROD FAM: CM&R COMPRESSION		DRAWING NO	REV												
		50009737	A												
		SIZE													
		D													
		DOCUMENT TYPE: SALES													
		REL LEVEL: Released													
		SHEET 1 OF 1													