

STRANDED COPPER CONDUCTOR ACCOMMODATED			BOLT SIZE	METRIC BOLT SIZE	COLOR CODE	DIE INFORMATION		MECHANICAL RATCHET						HYDRAULIC						DIELESS (# CRIMPS)	WIRE STRIP LENGTH	REV	DATE	DESCRIPTION	ECO	BY	C'H'K
CODE (AWG)	NAVY	METRIC SIZE (CLASS 2)				DIE INDEX	TYPE	YIMRTC	OUR840	MD6 MD7	MD6--R2 MD7-34R	PAT600 PATMD6	Y34A Y34B Y34BH	Y35, Y39 Y750, PAT750	Y46 PAT46	Y45	Y48B	Y60BHU	A			11/27/2012	NEW SALES DRAWING CREATED	29055	SS	MA	
350 kcmil	350	----	1/2	M12	RED	18 324	RED DIE SET	----	----	----	W31RT (4) W31VT (4)	W31RT (4) W31VT (4)	----	U31RT (4) U29ART (4)	U31RT (4) U29ART (4)	U31RT (4) U29ART (4)	C31R (1) C29AR (1)	L31RT (1) L29ART (1)	HYDRAULIC: Y644 (1) PAT644 (1) Y81KFT - SERIES (2) Y4PC834 - SERIES (2)	2 - 1/16"							
							NEST	----	----	----	----	----	B31D (2) A31D (2) Y34PR	U31D-1 (2) Y34PR	U31D-1 (2) Y34PR	U31D-1 (2) Y34PR	C31D-1(1) Y48PR	----									
							INDENTOR	----	----	----	----	----	----	----	----	----	----	----									

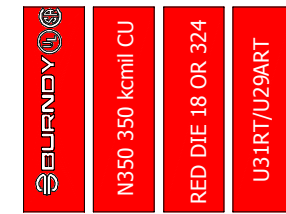

BARREL MARKING

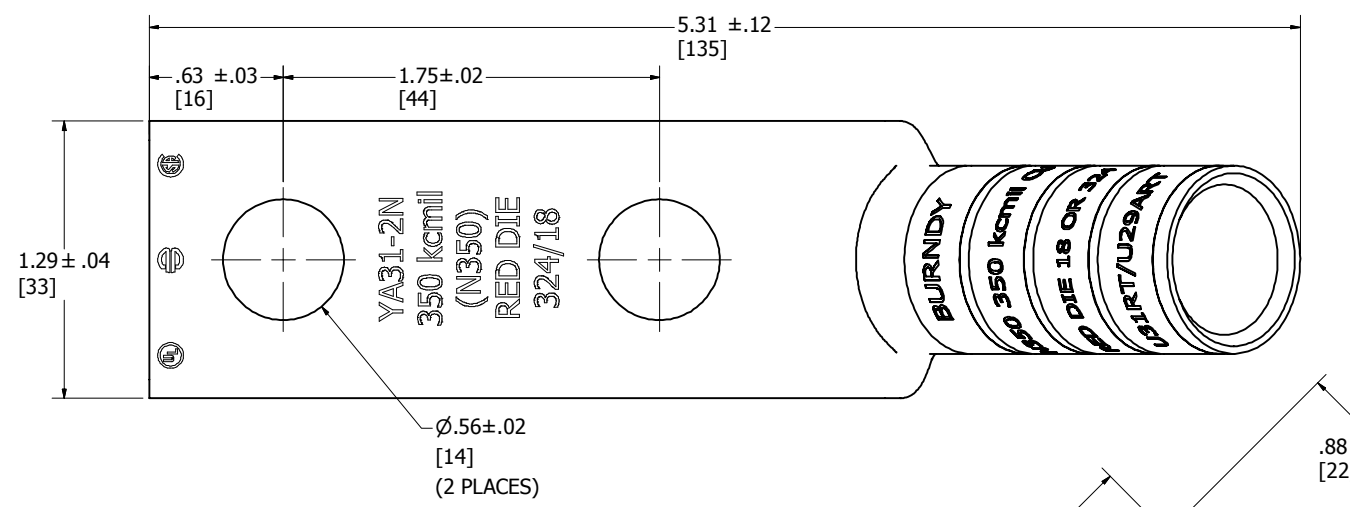
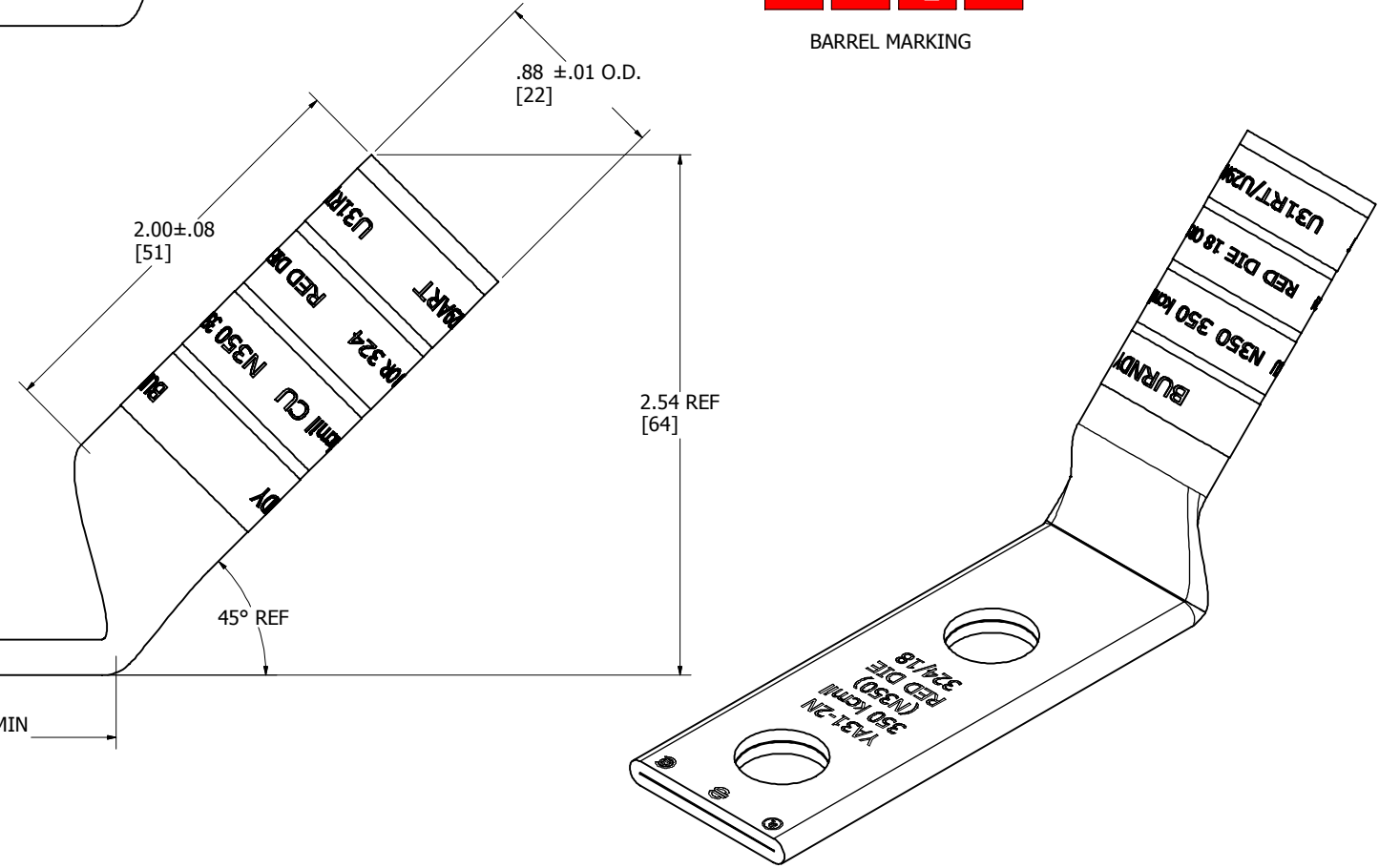

NOTES:

1. MATERIAL: COPPER TUBING
2. FINISH: TIN PLATED.
3. CATALOG # PT6515 ADAPTOR IS REQUIRED TO USE "U" DIES IN Y45 SERIES TOOLS.
4. CATALOG # PUADP-1 ADAPTOR IS REQUIRED TO USE "U" DIES IN Y46 SERIES TOOLS.
5. Y35P3 INDENTOR ADAPTOR REQUIRED FOR Y34PR INDENTOR.
6. PERMANENT DIE IN TOOLING.
7. DIMENSIONS IN BRACKETS [] ARE IN MILLIMETERS ROUNDED OFF TO THE NEAREST MILLIMETER, UNLESS OTHERWISE NOTED, AND ARE FOR REFERENCE ONLY.
8. FOR USE BY CUSTOMERS THAT HAVE THIS HYPRESS.™ NO NEW Y34A HYPRESS™ TOOLS ARE BEING PROCESSED. Y34A USES A--D TYPE NEST DIES.
9. UL LISTED AND CSA CERTIFIED WIRE CONNECTOR.
10. "X", "W-RT", "W-VT", "U", & "L" DIE SETS ARE COLOR CODED. "A", "B", AND "C" DIES ARE NOT COLOR CODED. NESTS AND INDENTOR TYPE ARE NOT COLOR CODED.

TO ORDER BURNDY® PRODUCTS CALL		HYLUG™	
UNITED STATES 1-800-346-4175 (LONDONDERRY, NH)		ITEM NO: 50252R	
CANADA: 1-800-361-6975 (QUEBEC) 1-800-387-6487 (ALL OTHER PROVINCES)		CAT. NO: YA312N45	
FOR PRODUCT INFO: http://www.burndy.com		DRAWN BY: S. SRIRAM 11/27/2012 CHECKER: J. MICHAUD 05/02/2013 DSN APRVL: R. ROMAN 04/26/2013 MFG APRVL: M. KNAPTON 03/18/2013 QA APRVL: T. WATTS 03/18/2013 MKT APRVL: J. SYLVIA 05/03/2013	
PROD FAM: CM&R COMPRESSION		DRAWING NO	REV
PROJECT #: --		50010009	A
DOCUMENT TYPE: SALES		SIZE	
REL LEVEL: Released		D	
		SHEET 1 OF 1	