

CAT. NO.	WIRE RANGE	STUD SIZE [METRIC SIZE]	MECHANICAL TOOLING	HYDRAULIC TOOLING				DIELESS TOOLING	NO. CRIMPS	WIRE STRIP LENGTH	REV	DATE	DESCRIPTION	ECO	BY	C'H'K.
				DIE INDEX	TOOL CAT. NO.	DIE TYPE	DIE CAT. NO.				A	10/24/2012	CREATE SALES DRAWING	29190	RG	MA
YAD8CM4E8	8 AWG STR.CU CODE & FLEX [6-10]mm ²	#8 [4]	Y1MRTC, Y8MRB-1, RED GROOVE	1013	Y35, Y39, Y750, PAT750	NEST	UV8L	Y81KFT- SERIES PAT81KFT- SERIES Y4PC834- SERIES PAT4PC834- SERIES	1	3/8"						
						INDENTOR	Y34PL									

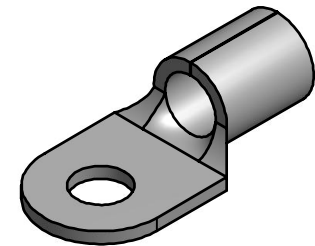
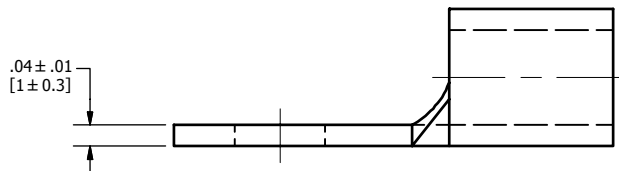
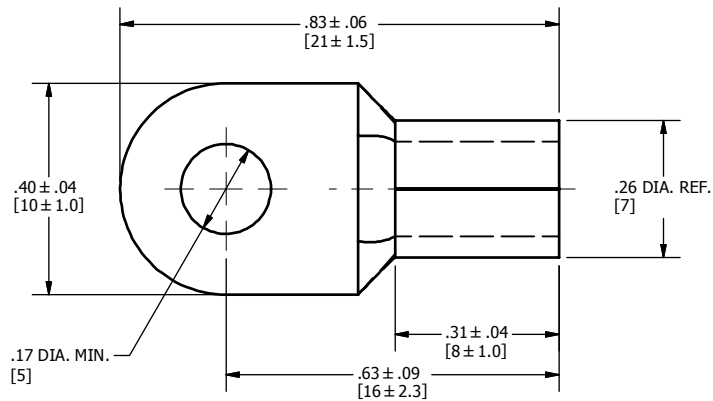

NOTES:

- MATERIAL: COPPER.
- FINISH: TIN PLATED.
- PERMANENT DIE IN TOOLING.
- Y35P3 ADAPTOR REQUIRED FOR Y34PL INDENTORS IN Y35, Y39, Y750 AND PAT750 TOOLS.
- DIMENSIONS IN BRACKETS [] ARE IN MILLIMETERS ROUNDED OFF TO THE NEAREST MILLIMETER, UNLESS OTHERWISE NOTED, AND ARE FOR REFERENCE ONLY.

TO ORDER BURNDY PRODUCTS CALL		NON-INSULATED BRAZED BARREL COPPER TERMINAL	
UNITED STATES		ITEM NO: 50002376	
1-800-346-4175 (LONDONDERRY, NH)		CAT. NO: YAD8CM4E8	
CANADA:		DRAWN BY: C.KAJEY 10/22/2012	
1-800-361-6975 (QUEBEC)		CHECKER: J.MICHAUD 11/29/2012	
1-800-387-6487 (ALL OTHER PROVINCES)		DSN APRVL: J.MICHAUD 11/29/2012	
FOR PRODUCT INFO: http://www.burndy.com		MFG APRVL: -- --	
		QA APRVL: S.GALE 11/29/2012	
		MKT APRVL: C.KOWALCZYK 11/29/2012	
		PROD PART: CNV/COMPRESSION	
		PROJECT #:	SIZE
		DOCUMENT TYPE: Sales	50010570
		REL LEVEL: Released	B
		DRAWING NO	REV
			A
		SHEET 1 OF 1	